

MANUALE DEL PROPRIETARIO

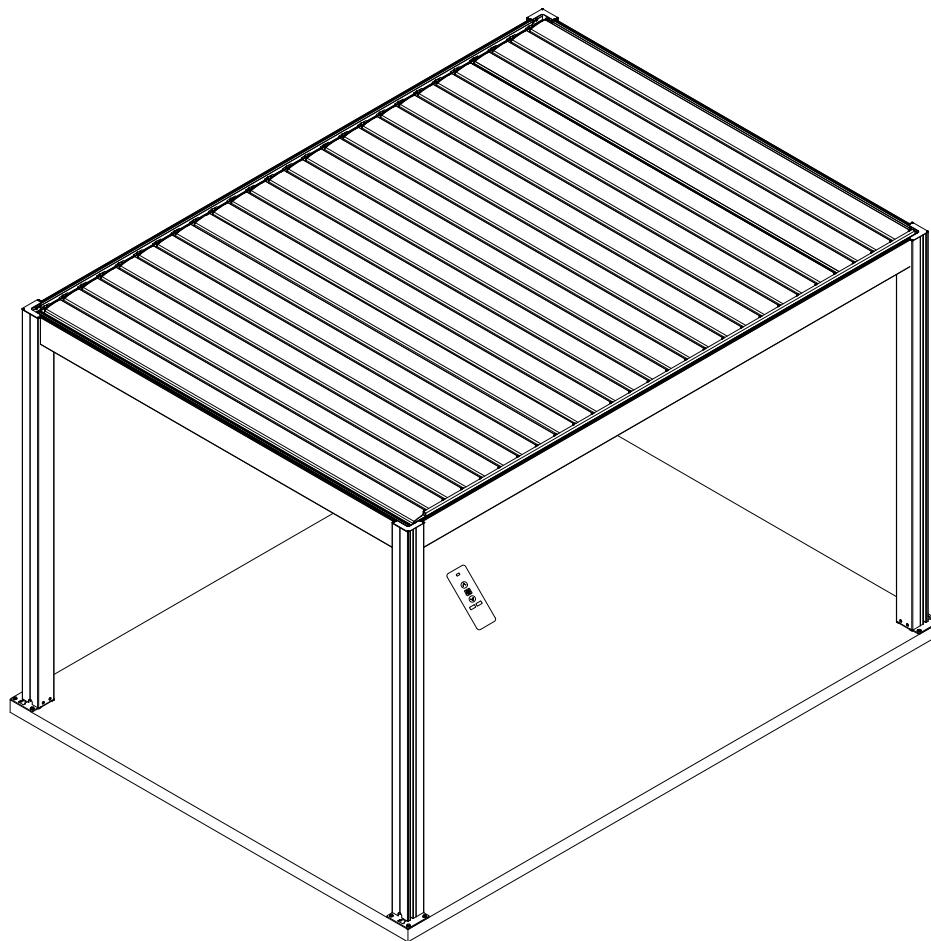

OTHER LANGUAGES

Pergolato 4x2.86M

Si prega di leggere questo manuale prima di utilizzare la pergola per la prima volta.

Si prega di conservare questo manuale per riferimento futuro.

Pergola

Apertura:Elettrico

Misurare:295.3 (Lunghezza) x409 (Larghezza) -cm

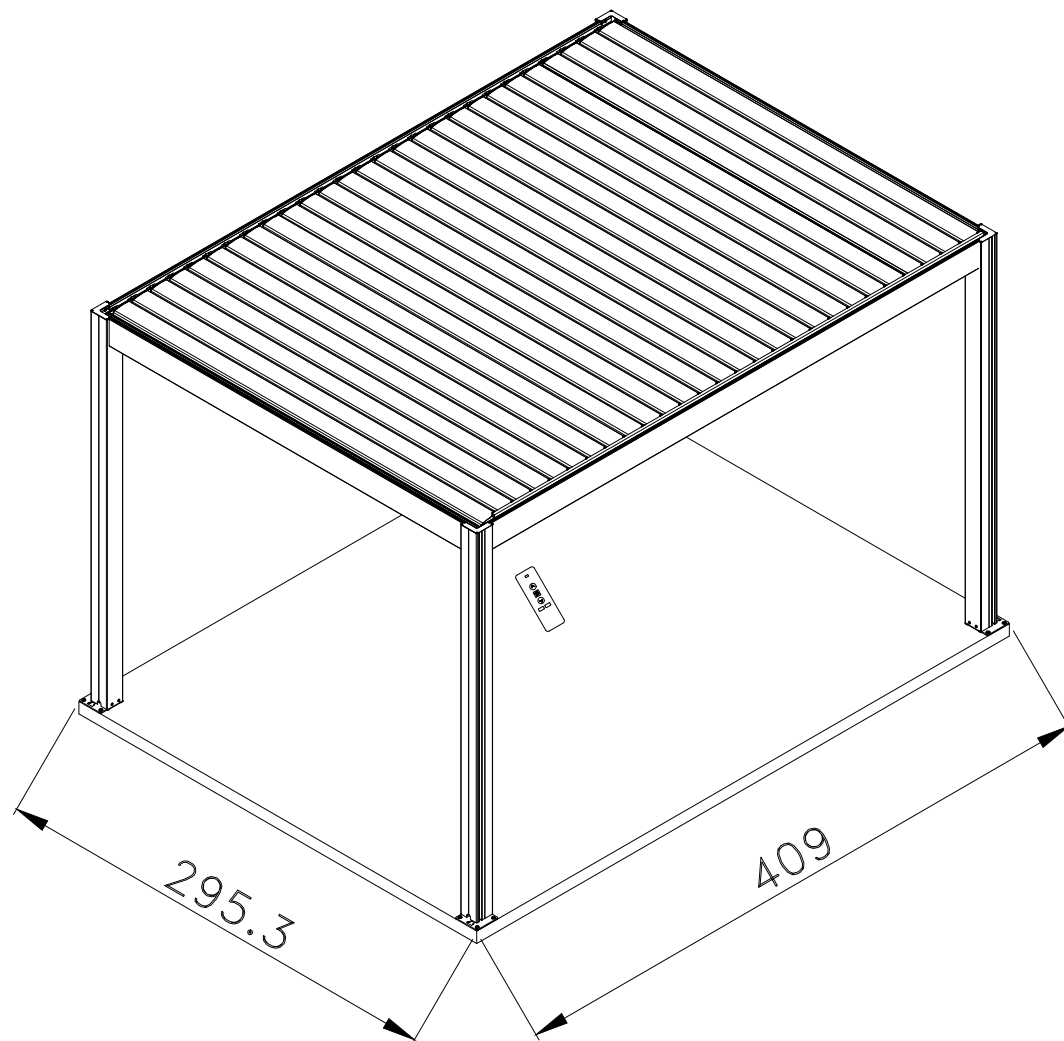

Note di installazione:

1. L'installazione richiede un minimo di tre persone: una per la misurazione e la marcatura, una per l'installazione e una come assistente.
2. Vengono forniti solo dispositivi di fissaggio per pavimenti in cemento. Nel caso in cui non sia presente una soletta in cemento sul terreno, è consigliabile realizzare delle solette in cemento in corrispondenza di ogni colonna. La lastra di cemento dovrebbe essere almeno di **500x500x500mm**.
3. Dopo aver assemblato il telaio della pergola, utilizzare una squadra, una livella e un righello per misurare il livello e la diagonale del prodotto per garantire le dimensioni della pergola. Le basi devono essere esattamente a livello senza alcuna tolleranza.
4. La pergola deve essere imbullonata al pavimento. Non ne prendiamo nessuna responsabilità in caso di crepe nelle piastrelle durante la foratura dei bulloni.
5. Sono necessari utensili elettrici: assicurarsi che funzionino correttamente e seguire le istruzioni di sicurezza.
6. Fare attenzione quando si utilizzano strumenti affilati.
7. Indossare indumenti protettivi compresi occhiali di sicurezza, elmetti e guanti.
8. Non salire né salire sul tetto.

Avvertenza di sicurezza

- . Si consiglia vivamente di indossare guanti per il montaggio.
- . Non installare la pergola in condizioni meteorologiche avverse, come vento o pioggia.

- . **Non toccare i cavi con i profili in alluminio.**
- . Indossare sempre scarpe e occhiali protettivi durante l'installazione della pergola.
- . Tenere tutti i sacchetti di plastica fuori dalla portata dei bambini.
- . La colonna della pergola deve essere posizionata e fissata su una superficie piana.
- . **Non appoggiarsi alla colonna durante la fase di montaggio.**
- . Non permettere ai bambini di avvicinarsi alla scena durante la fase di montaggio.
- . Non avvicinarti al pergolato durante una tempesta o un tifone.
- . **Non tentare di salire sul pergolato sotto l'effetto di alcol o droghe.**
- . Quando si utilizzano scale o strumenti simili e utensili elettrici durante la fase di montaggio, assicurarsi di seguire le raccomandazioni di sicurezza del produttore.
- . Qualsiasi utensile caldo, come un trapano elettrico, non può entrare in contatto con il profilo della pergola.
- . Assicurarsi che non vi siano cavi o altri cavi nascosti sotto terra prima di posizionare la colonna.

Consigli generali

- . Questa pergola è composta da diversi componenti e il montaggio richiede almeno 90 minuti. La pergola non deve essere posizionata sotto un albero.
- . Se colleghi la colonna direttamente al cemento o ad una base simile, usa il fori preforati sulla base in dotazione.
- . Controllare il numero di profili e raccordi prima del montaggio e utilizzarli secondo l'elenco dei raccordi per profili per un facile montaggio.
- . Metti piccoli pezzi come viti in un contenitore per evitare perdite.
- . Si prega di prestare attenzione alla posizione della trasmissione sulla trave per evitare smarrimenti.
- . Pulisci regolarmente foglie, neve o altri oggetti dalla pergola.

Manutenzione e riparazione

- . Per pulire la pergola, utilizzare un detergente delicato e risciacquare con acqua. Non utilizzare acetone o prodotti detergenti abrasivi per pulire la superficie del profilo in alluminio.

Garanzia

- . La garanzia generale per lo scolorimento è di 5 anni, per il motore e l'illuminazione a LED 2 anni.

Strumenti di protezione e installazione

Equipaggiamenti protettivi:

1. Casco
2. Guanti
3. Kit di pronto soccorso di emergenza
4. Occhiali protettivi



Strumento di misura:

1. Metro a nastro (5 metri o più)
2. Righello quadrato
3. Livello

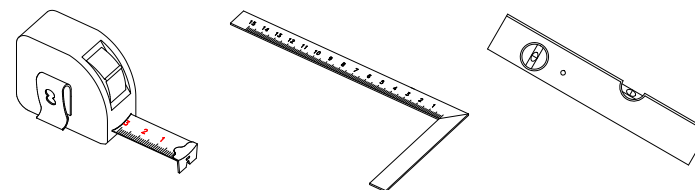





Utensili:

1. Scala da 2 metri (1,5 metri o più)
2. Chiave esagonale da 13 mm
3. Chiave esagonale da 17 mm
4. Trapano elettrico
5. Punta da trapano elettrico (punta da 10 mm)
6. Pennarello o matita
7. Martello di gomma
8. Sigillante e pistola per colla



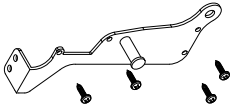
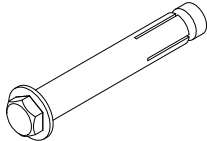
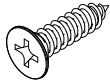
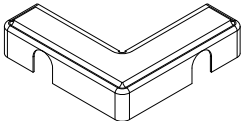
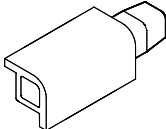
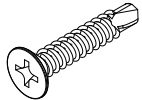
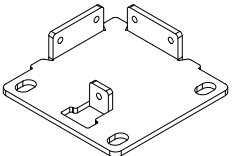
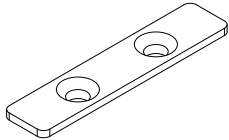
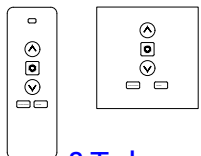
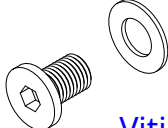

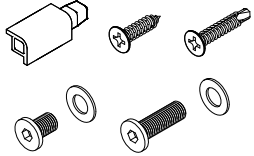

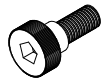
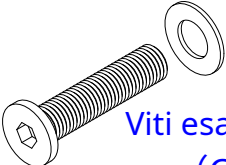
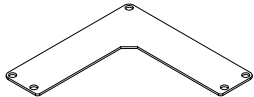
Silicon

Elenco accessori e viti

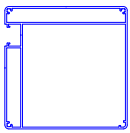
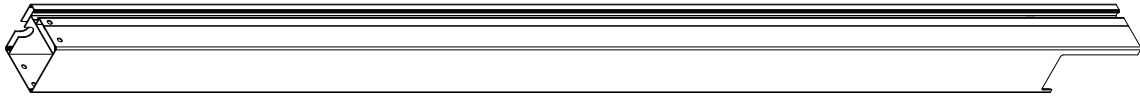
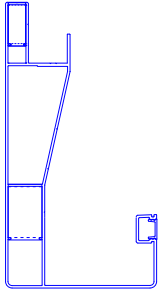
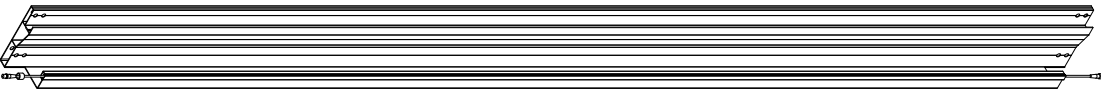
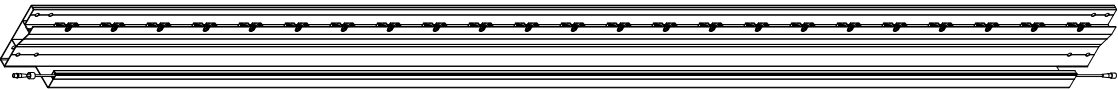
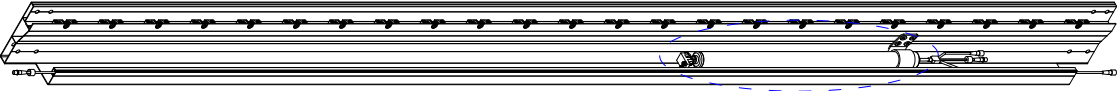
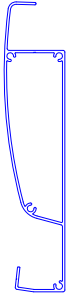
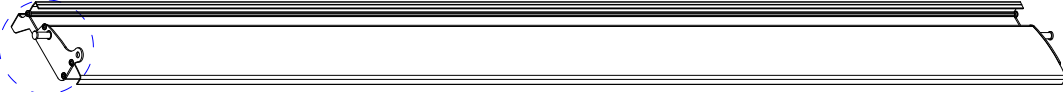
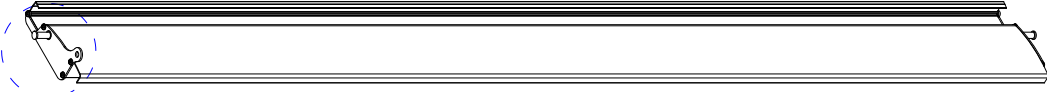
<p>①</p>	 <p>x1 Tappo terminale per Louvre di collegamento del motore e viti a testa piatta 4*20</p>	<p>⑦</p>	 <p>x16 Vite di espansione M8*80</p>	<p>⑬</p>	 <p>x12 Vite a testa piatta 4.2*16</p>
<p>②</p>	 <p>x4 Copertura della piastra di base</p>	<p>⑧</p>	 <p>x4 L'angolo della posta Pezzo di estensione</p>	<p>⑭</p>	 <p>x8 Vite di perforazione 4,2 * 19</p>
<p>③</p>	 <p>x4 Piastra di base</p>	<p>⑨</p>	 <p>x56 Tappo supporto albero</p>	<p>⑮</p>	 <p>x1 Ricevitore & Telecomando sul tetto</p>
<p>④</p>	 <p>x16 Viti esagonali M8*12 (Con Rondella)</p>	<p>⑩</p>	 <p>x112 Vite a testa svasata M5*16</p>	<p>⑯</p>	 <p>x1 Pezzi di ricambio</p>
<p>⑤</p>	 <p>x16 Viti esagonali M8*25 (Con Rondella)</p>	<p>⑪</p>	 <p>x28 Vite a testa esagonale M6*5</p>	<p>⑰</p>	
<p>⑥</p>	 <p>x16 Viti esagonali M8*35 (Con Rondella)</p>	<p>⑫</p>	 <p>x4 Copertura superiore del montante a L</p>	<p>⑱</p>	

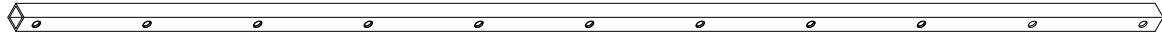
Elenco profili

<p>A-1 ~ A-4</p>			<p>x4 Inviare</p>
<p>B-2 B-4</p>			<p>x2 Trave e grondaia</p>
<p>B-1</p>			<p>x1 Trave e grondaia (con supporto per albero)</p>
<p>B-3</p>			<p>x1 Trave e grondaia (con supporto per albero) + motore</p>
<p>C-1</p>			<p>x1 Louvre di collegamento del motore</p>
<p>C-2</p>			<p>x27 Louvre</p>
<p>D</p>			<p>x1 Asta di controllo</p>
<p>E</p>			<p>x4 Copertura per scanalatura a T</p>

Disegno di layout dei profili in alluminio

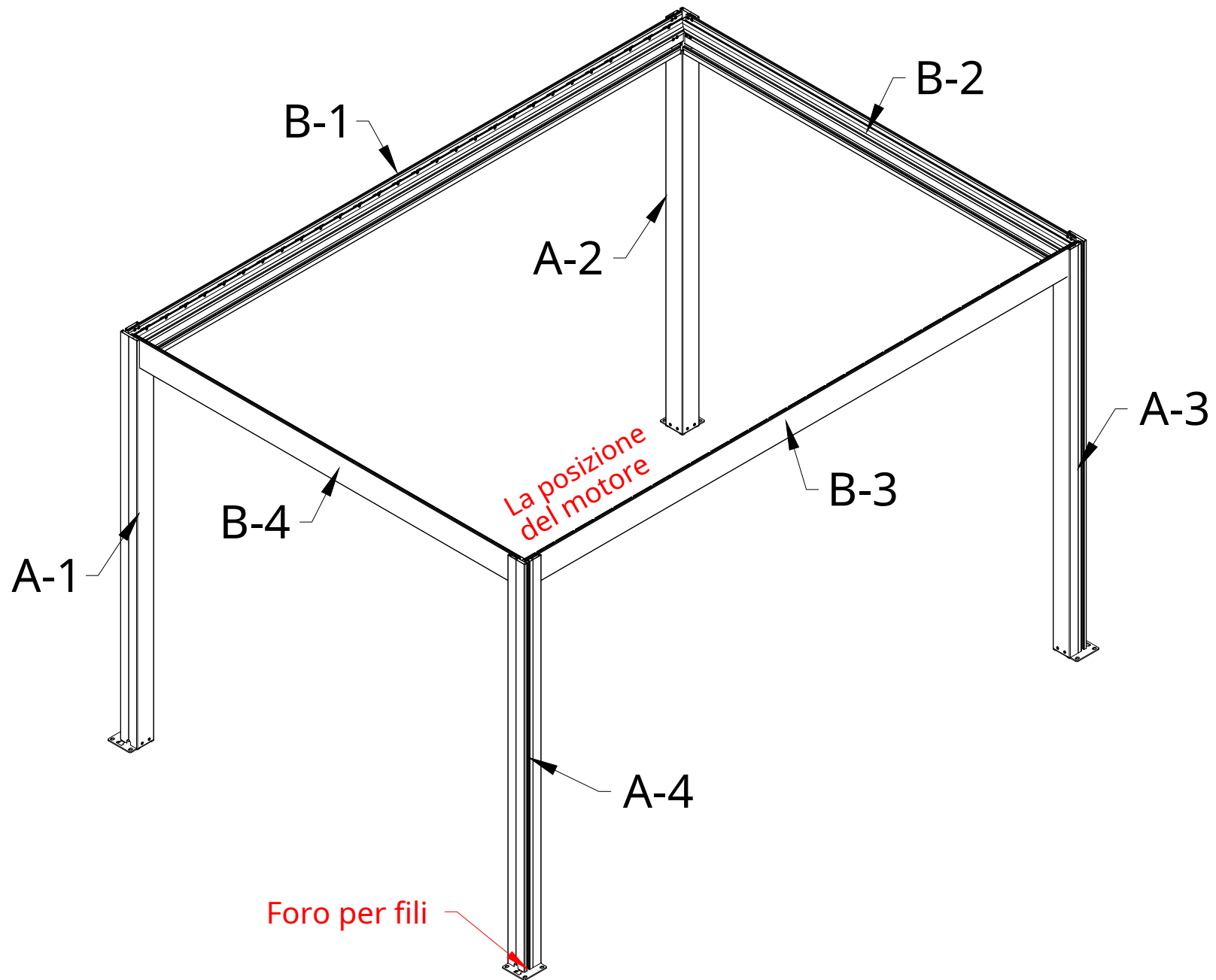

1

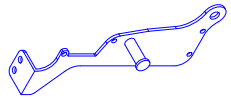

x1



x4

Installazione del Louvre di collegamento del motore

1) Fissare il coperchio della lama sul Louvre di collegamento del motore C-1 con viti a testa piatta 4*20.

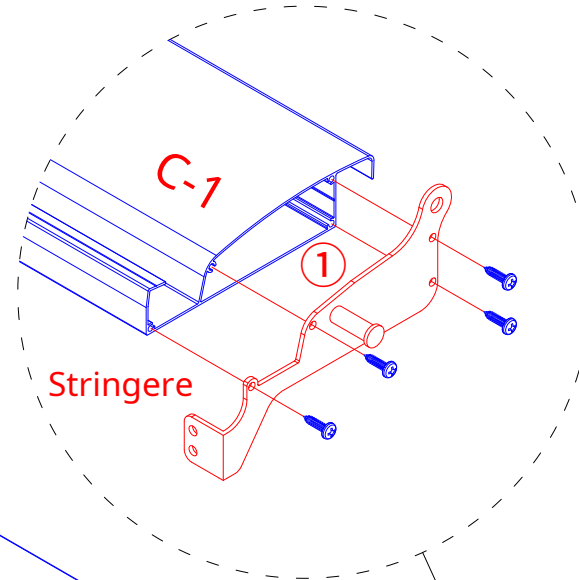

Passo 1

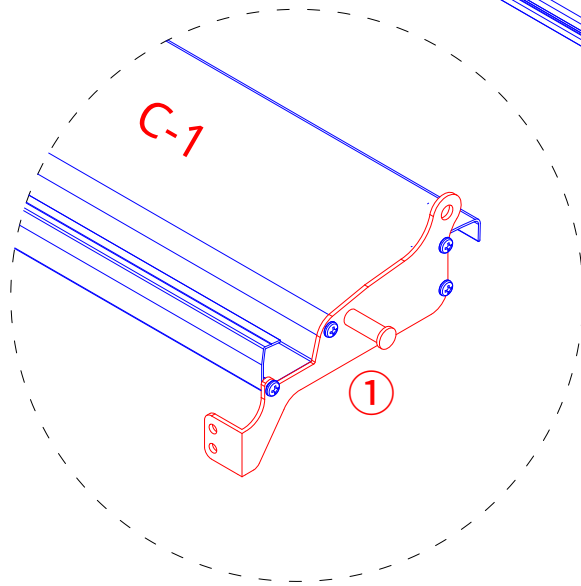

Passo 2

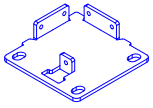
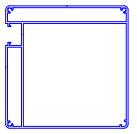
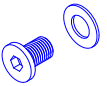

Se il luogo di installazione è angusto, le coperture delle lame possono essere installate dopo l'installazione della struttura.

③		x4	A-1 ~ A-4		x4
④		x16			

Assemblare la struttura

1) Come mostrato, inserire il coperchio della piastra di base② nei post, quindi allineare i fori nella piastra di base③ con i fori nei montanti e bloccare la piastra di base③ ai montanti con le viti esagonali M8*12 (con rondella)④.

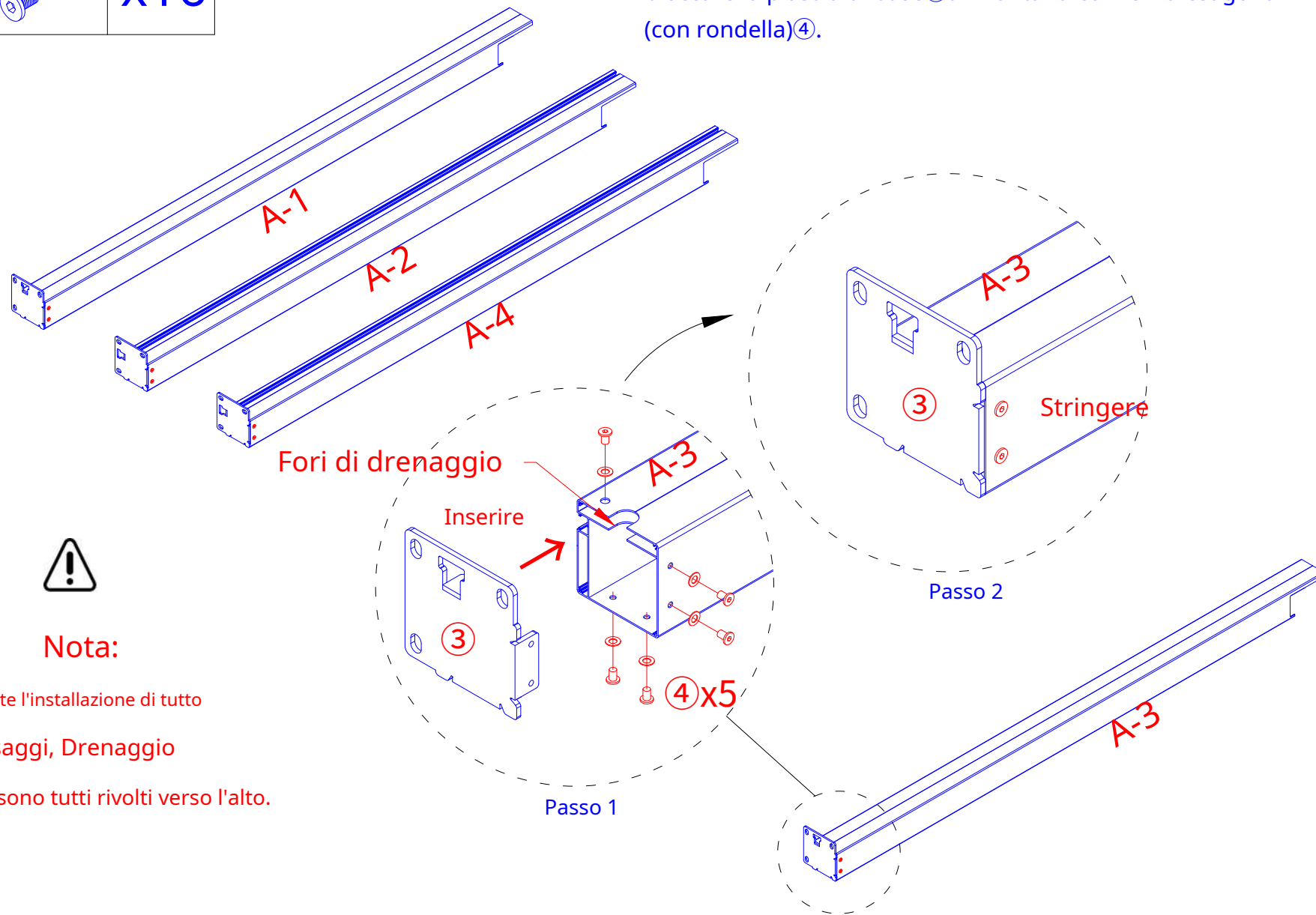

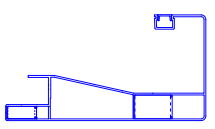
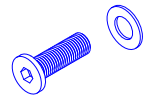
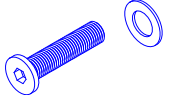
B-1 B-3		x2
⑤		x8
⑥		x8

Assemblare la struttura

2) Come mostrato, inserire la trave e la grondaia (B-1, B-3) nei post, quindi riparato la trave e la grondaia (B-1, B-3) sui montanti con viti esagonali M8*25⑤ e viti esagonali M8*35⑥.

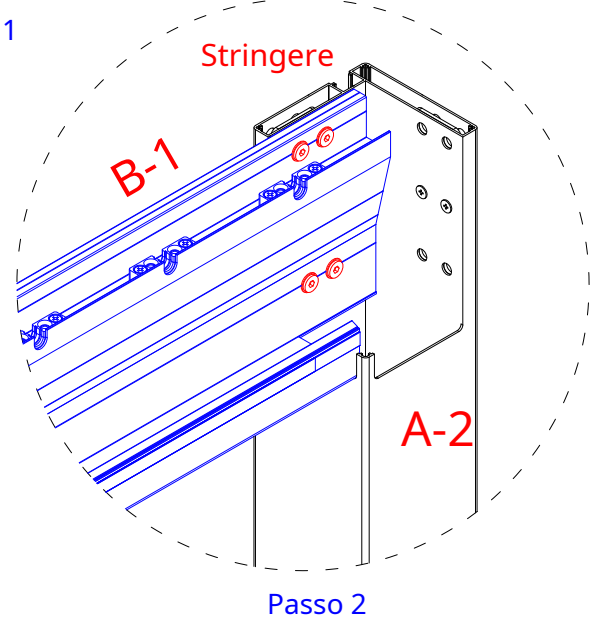
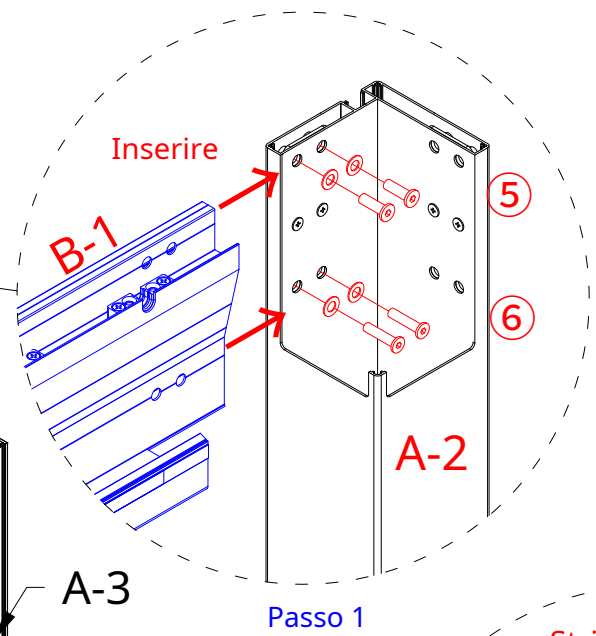
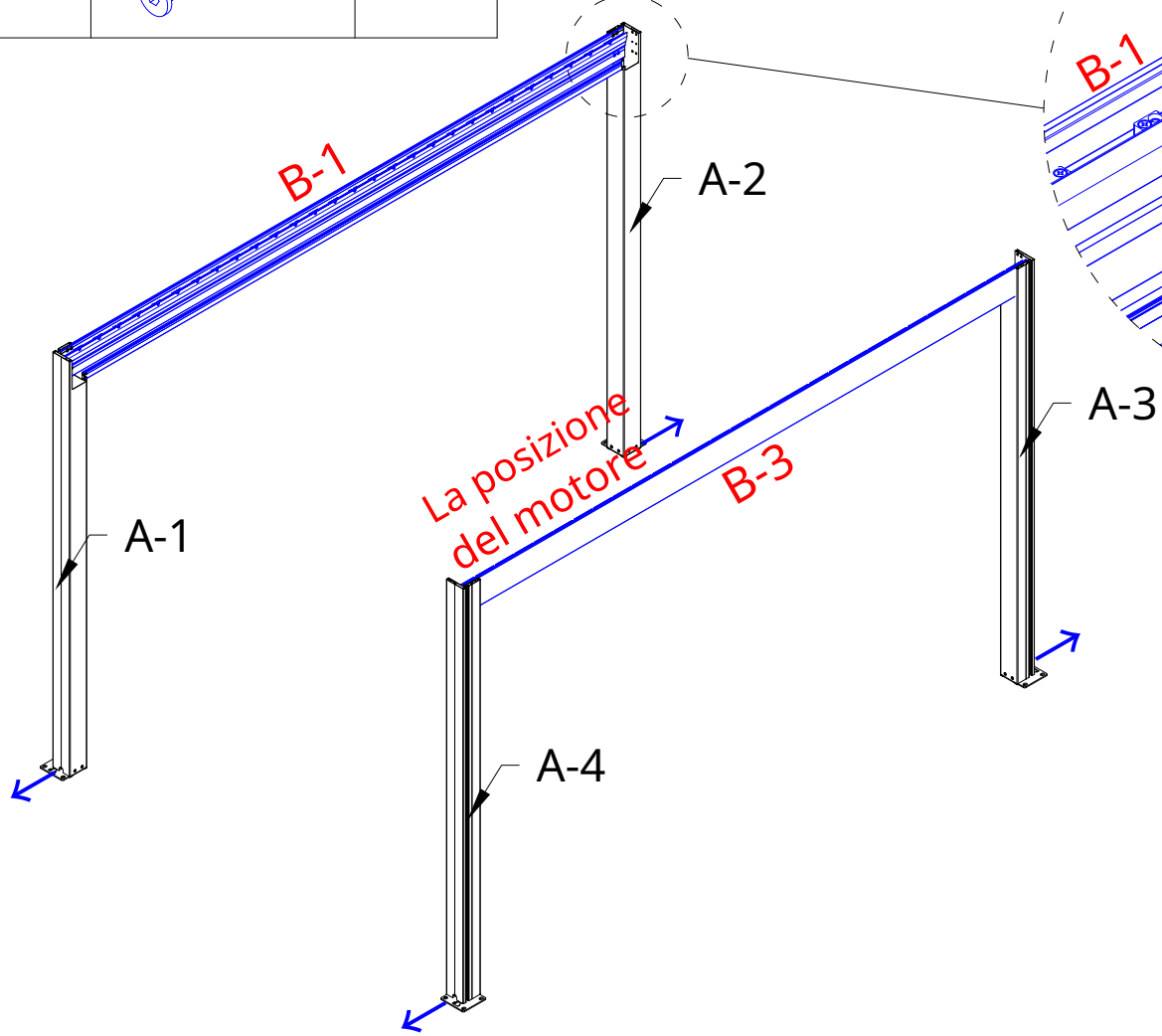

B-2 B-4		x2
⑤		x8
⑥		x8

Assemblare la struttura

3) Come mostrato, inserire la trave e la grondaia B-2, B-4 nei post, poi risolto il trave e grondaia B-2, B-4 sui montanti con viti esagonali M8*25⑤ e viti esagonali M8*35⑥.

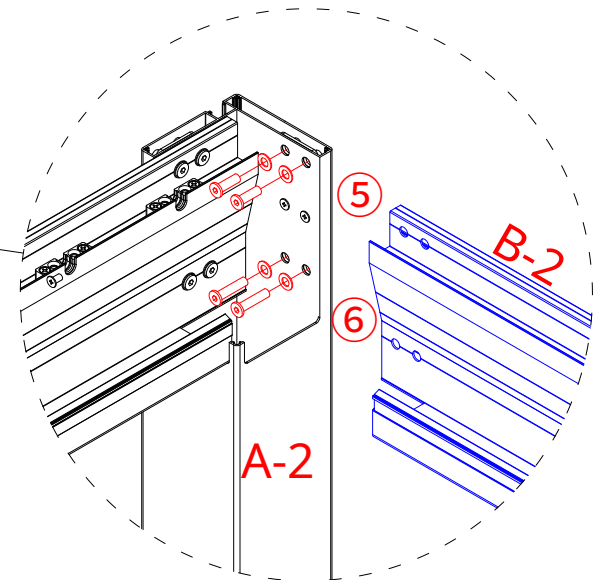
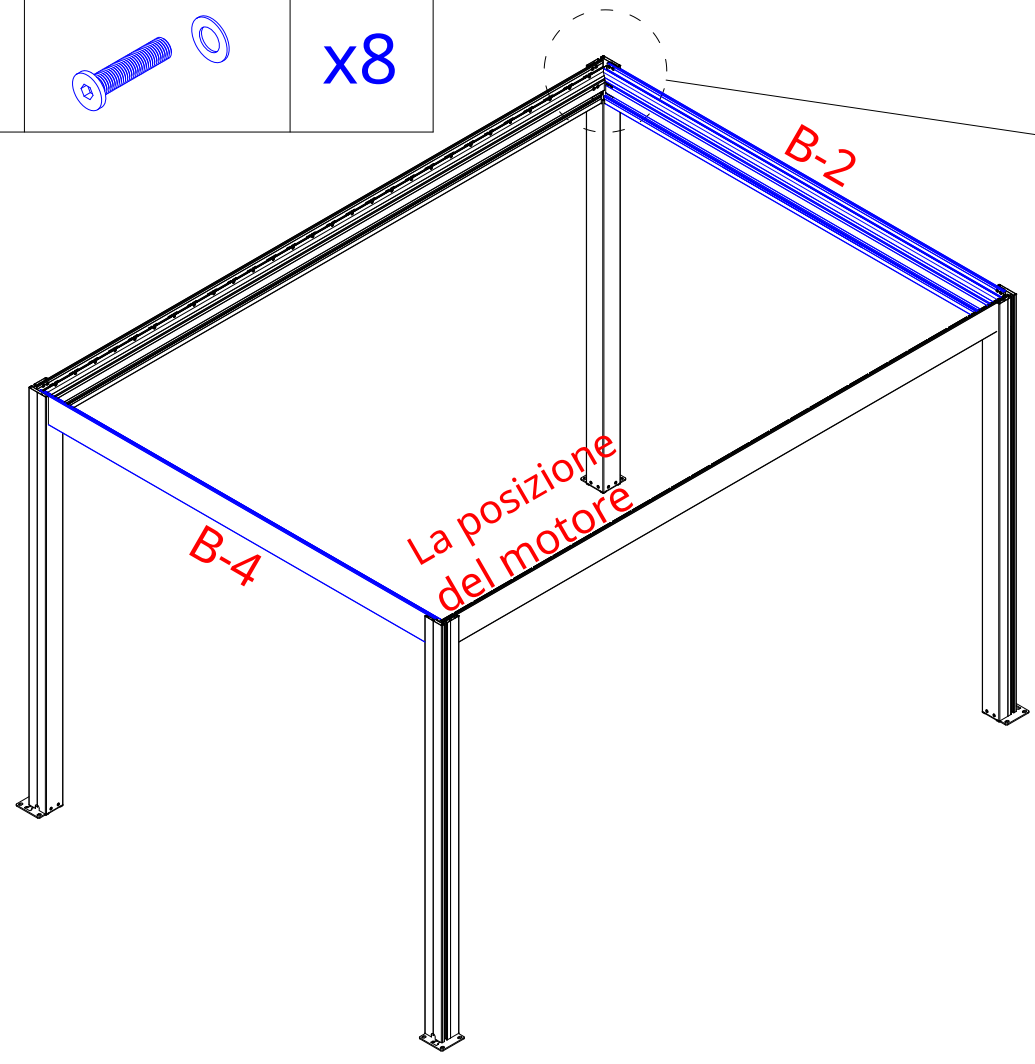

Passo 1

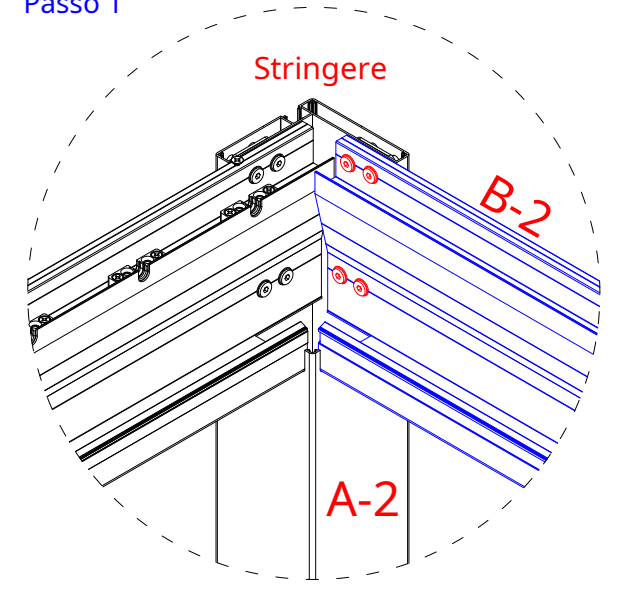

Passo 2

7

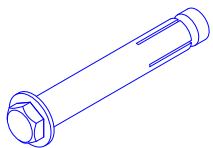

x12

Nota:

Prima di fissare la piastra di base, è necessario assicurarsi che le diagonali dei 4 montanti abbiano la stessa lunghezza. Assicurarsi che la dimensione $W1=W2$, $W3=W4$.

Fissare la pergola al terreno

- 1) Utilizzare la vite ad espansione 12 M8*80⁷ fornito, se il terreno è in cemento. In caso contrario dovrai trovare un'altra soluzione per fissare la pergola sulla superficie desiderata.
- 2) Spostare la pergola nella posizione di installazione adeguata, quindi segnare la posizione dei quattro montanti con la matita, rimuovere la pergola e utilizzare il trapano elettrico per realizzare 12 fori secondo il marchio. Riportare la pergola in posizione e fissare la piastra di base con la vite ad espansione M8*80⁷.

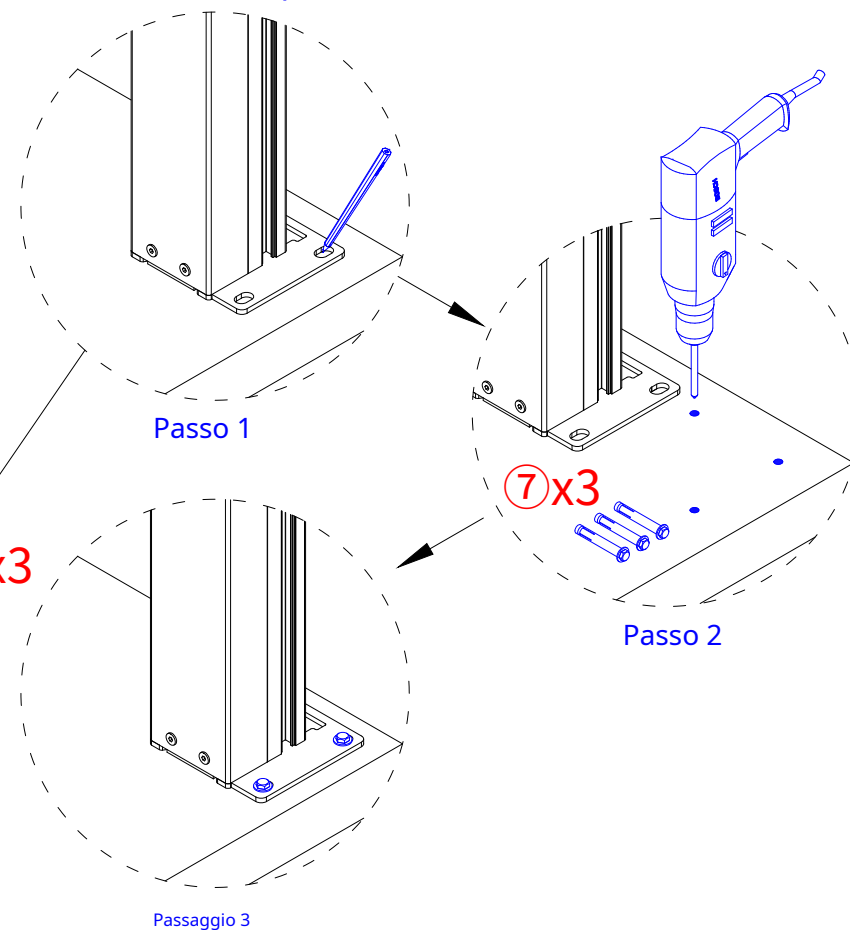
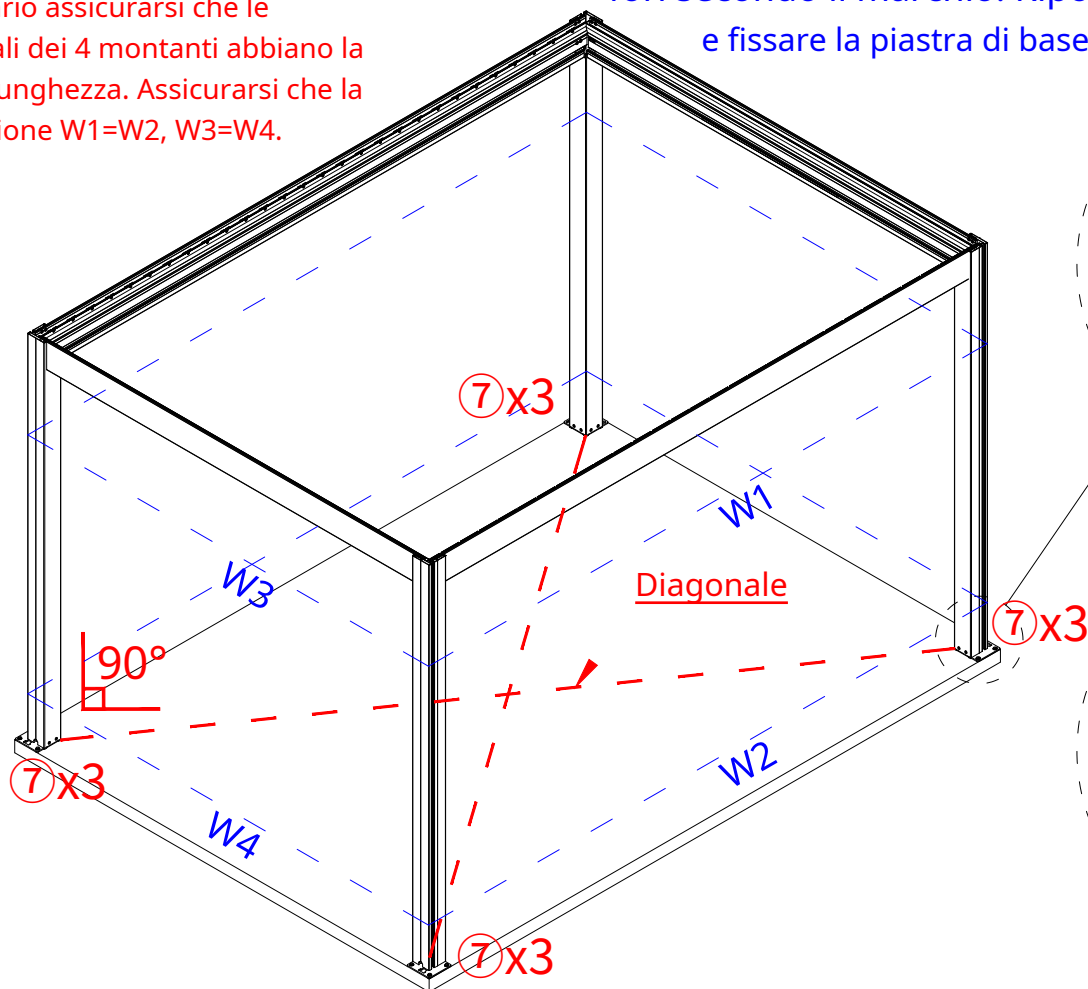

È responsabilità dell'utente assicurarsi che la pergola sia fissata. Il produttore non è responsabile per danni causati alla pergola (o ai suoi accessori) da calamità naturali o eventi particolari. Qualsiasi pergola non riparata potrebbe essere spazzata via e causare danni, questa responsabilità non sarà attribuita al produttore. Controllare regolarmente la pergola per assicurarsi che rimanga stabile e saldamente attaccata al terreno. Una pergola che si stacca dalla sua posizione e subisce o provoca danni non sarà coperta da garanzia.

 **Filo LED**

 **Cavo di alimentazione**

Far passare i fili

Quando si dispongono i cavi, farli scorrere nel palo dalla tacca all'estremità superiore del palo, quindi tirare i cavi verso il foro di uscita, quindi estrarre i cavi dalla presa e infine uscire dal foro nella parte inferiore della posta.

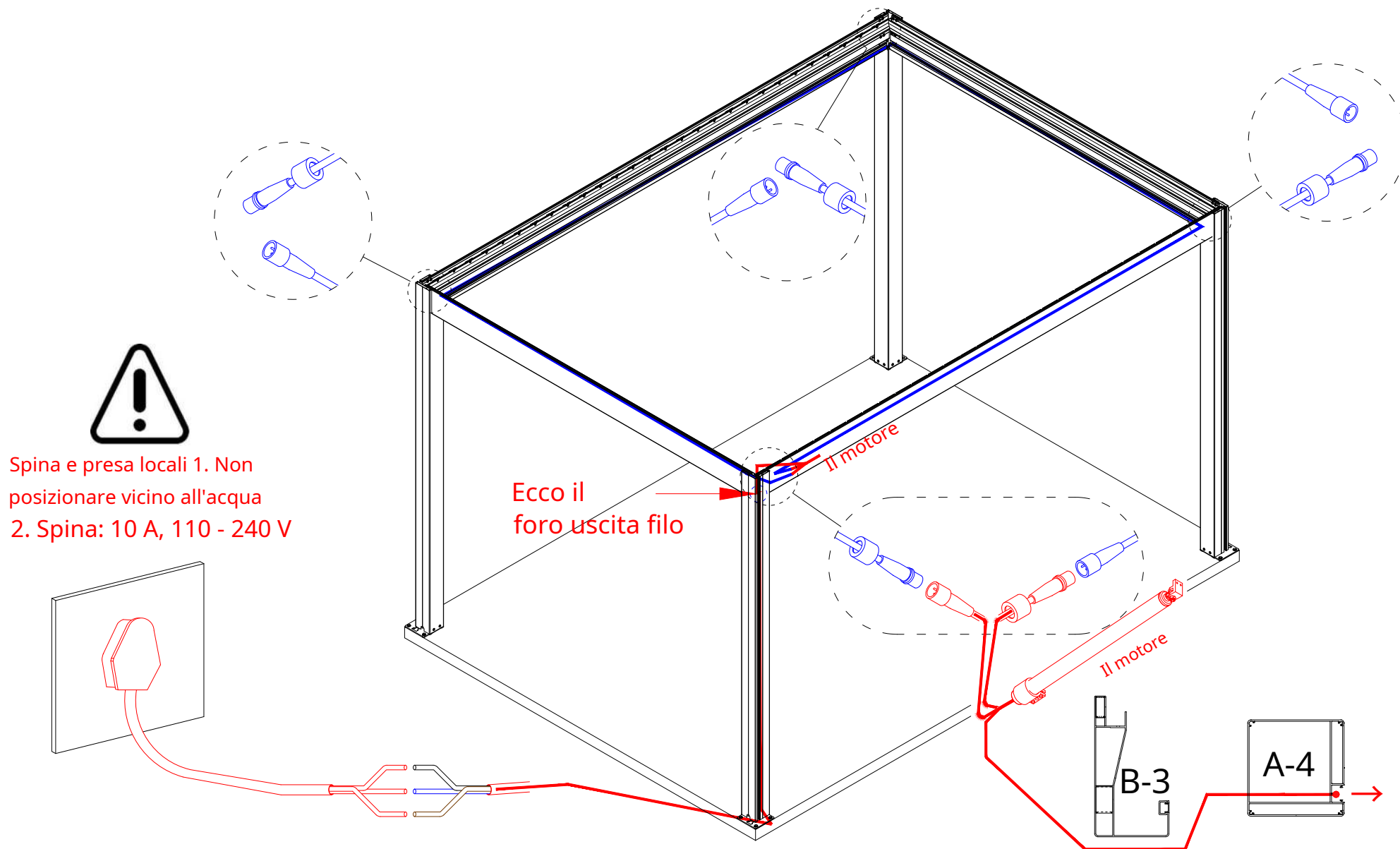



Nota: seguire i passaggi per collegare correttamente il cavo, altrimenti il motore sarà difettoso.



La spina non è fornita

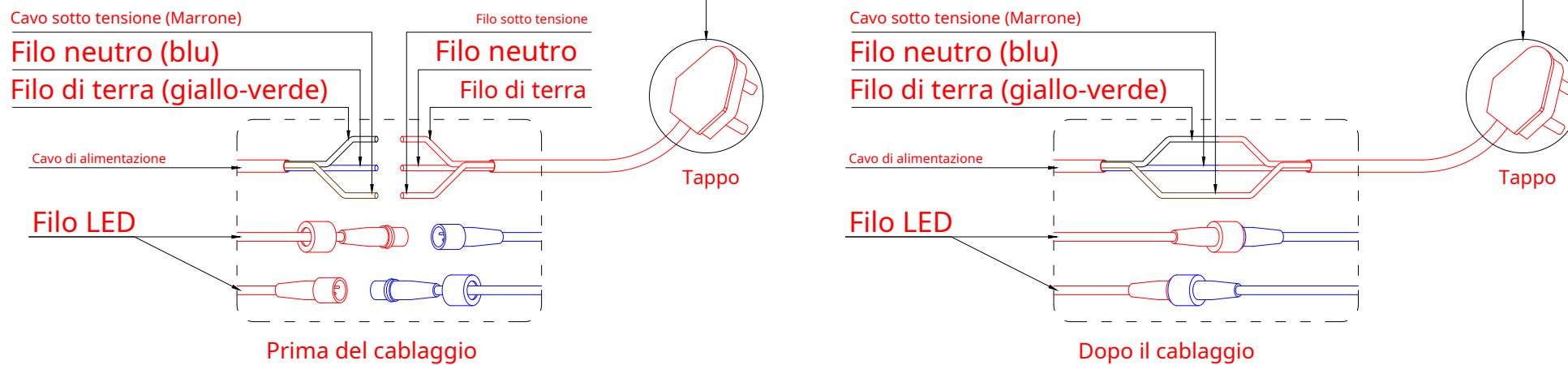

8

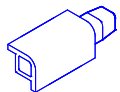

x4

Fissare l'estensione dell'angolo del montante

1) Come mostrato, far scorrere l'elemento di estensione dell'angolo del montante nella parte superiore dell'angolo del montante.

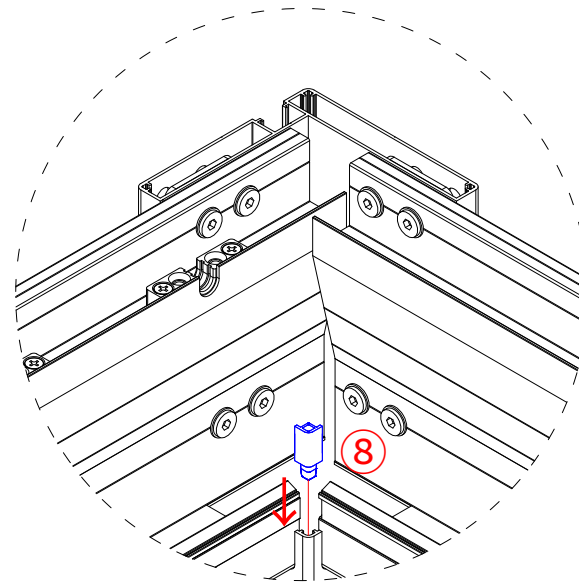
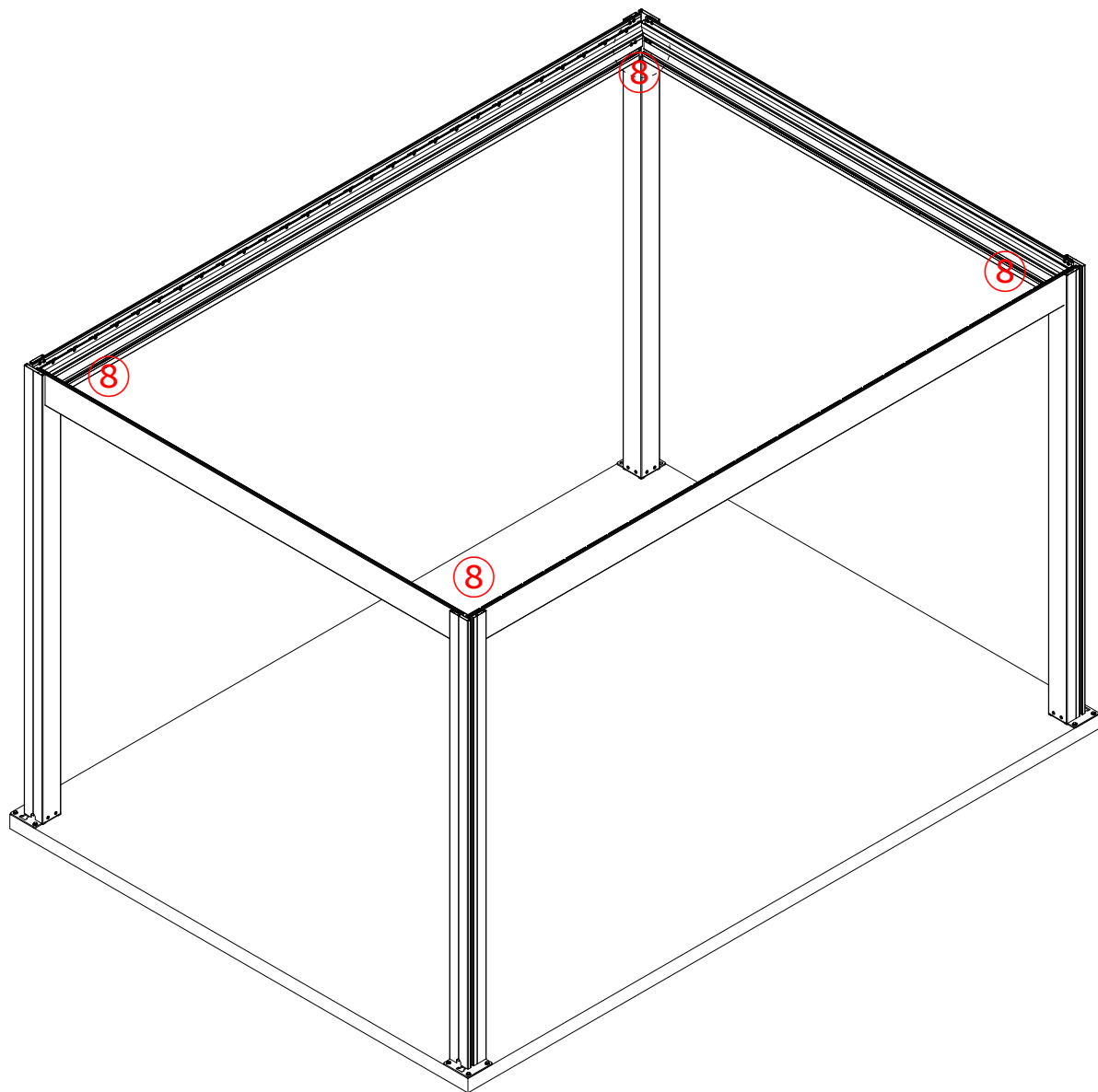

Passo 1

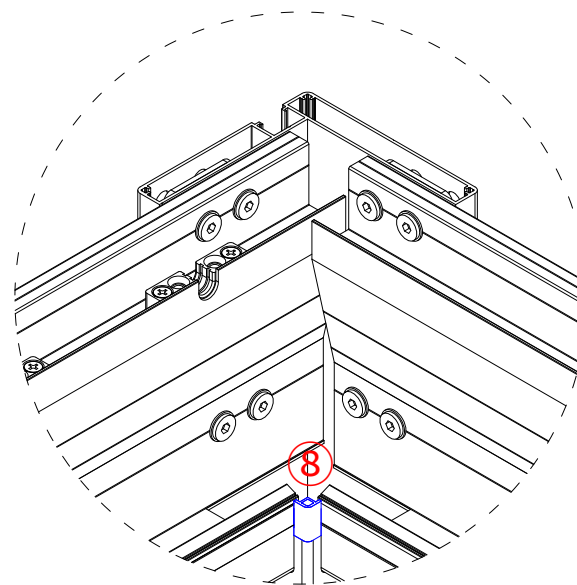

Passo 2

C-1



x1

Installazione del Louvre

- 1) Come mostrato, la feritoia di collegamento del motore C-1 si inserisce direttamente nella scanalatura.
- 2) Collegare la staffa del braccio del motore al cappuccio terminale del Louvre di collegamento del motore C-1.

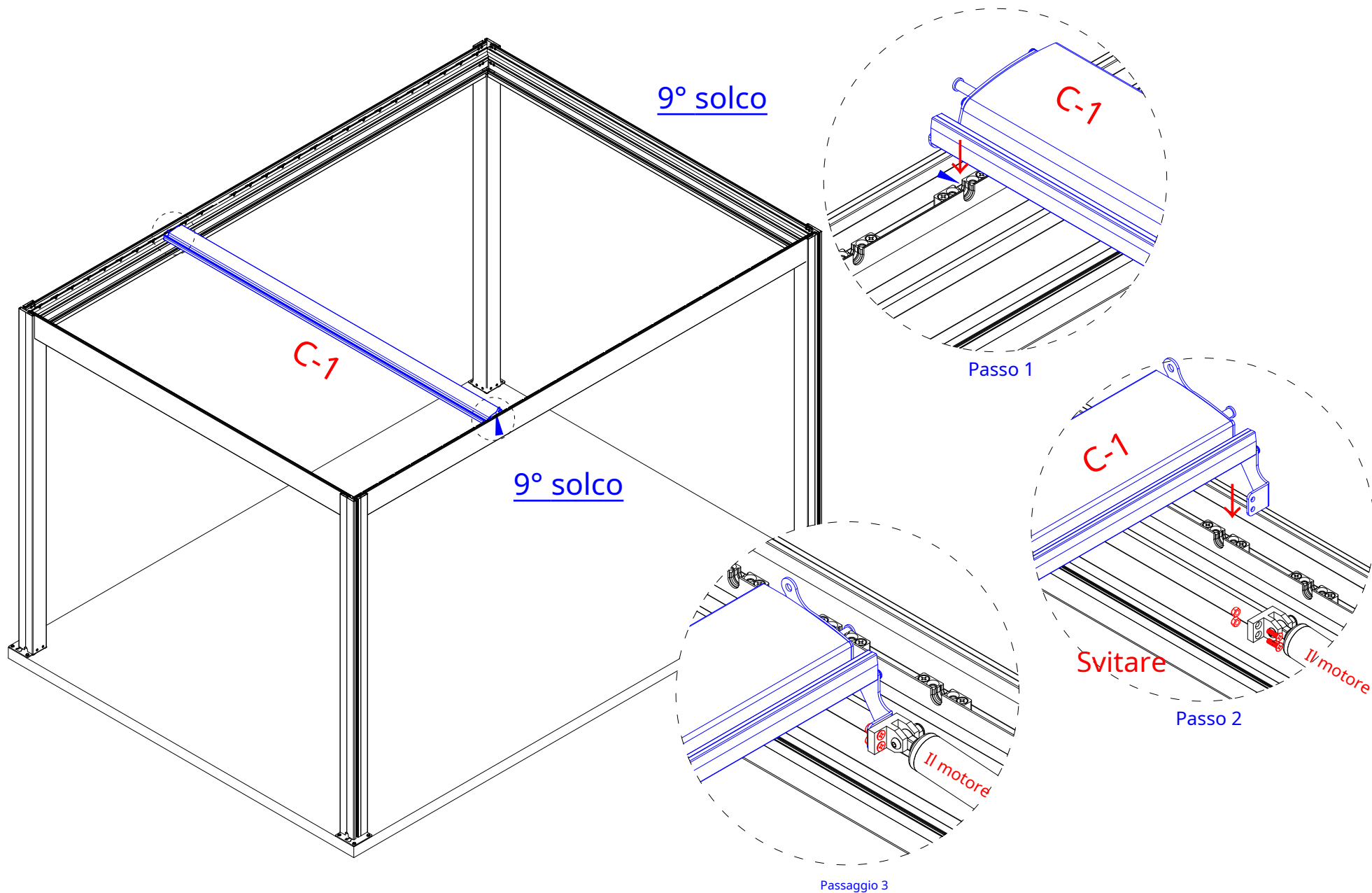

C-2



x27

Installazione del Louvre

3) Come mostrato, la feritoia C-2 scatta direttamente nella scanalatura.

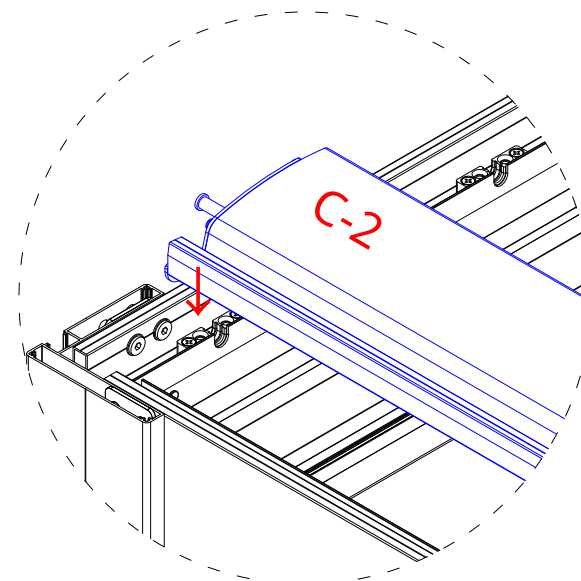
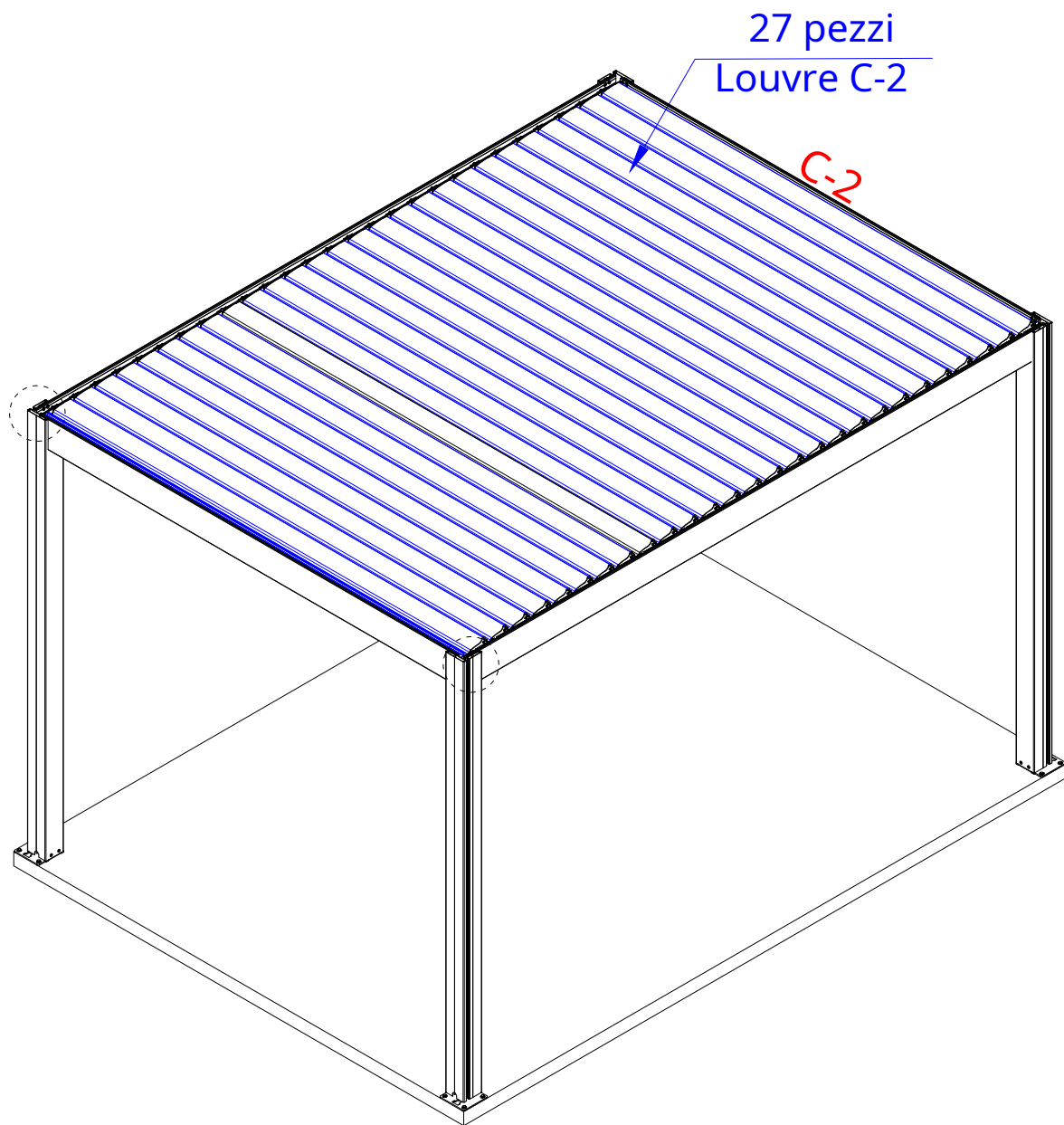

Passo 1

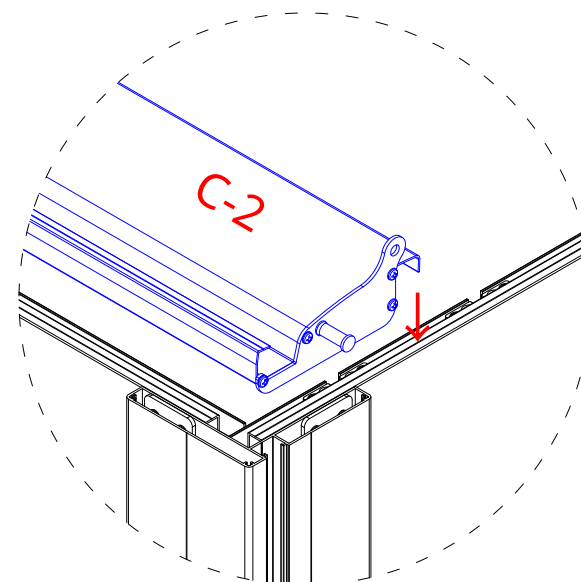

Passo 2

9

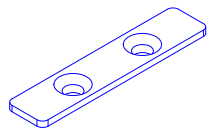

x56

10



x112

Installazione del Louvre

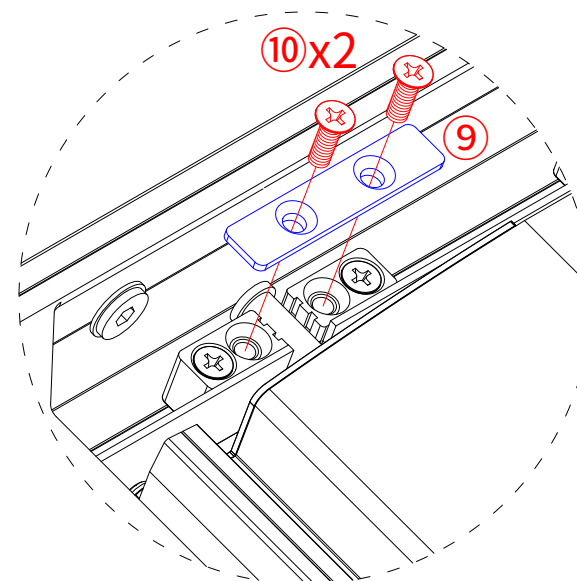
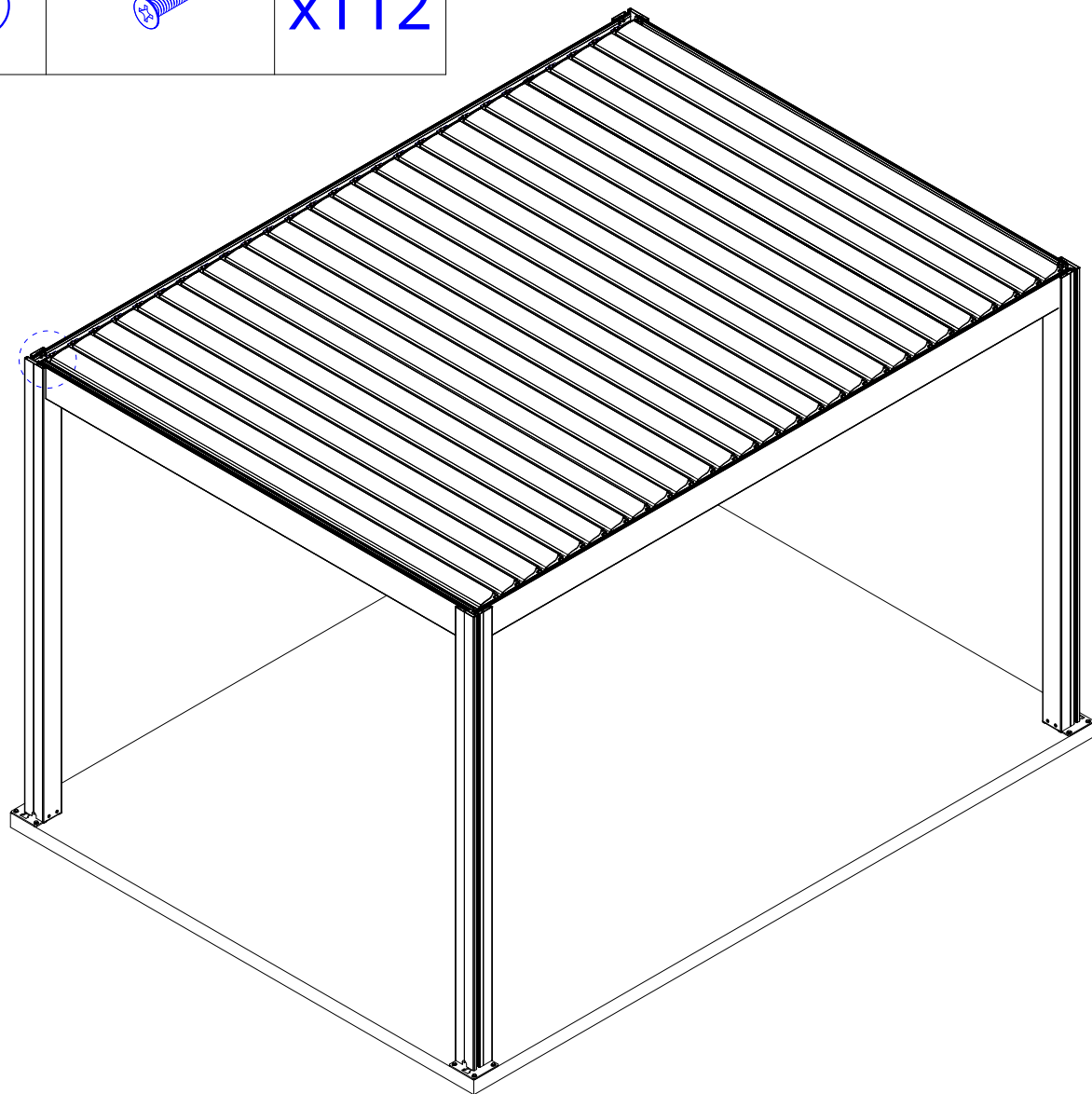

4) Come mostrato, fissare il cappuccio del supporto dell'albero 9 accessosupporto dell'albero con Vite a testa svasata M5*16 10.

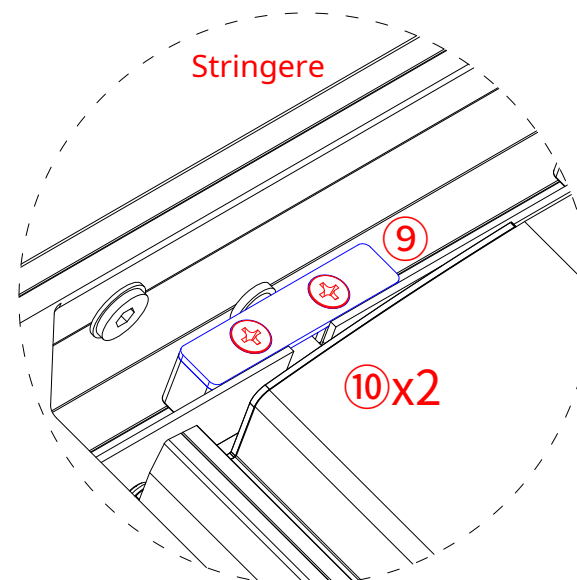

Passo 1



Passo 2

D		x1
11		x28

Installazione del Louvre

5) Come mostrato, utilizzare la vite a testa esagonale M6*5¹¹ attraverso il foro (sull'asta di comando D), quindi fissato sull'ottica.

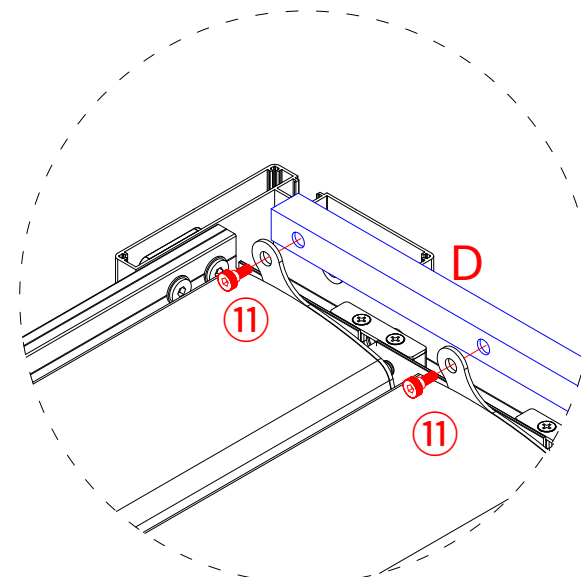
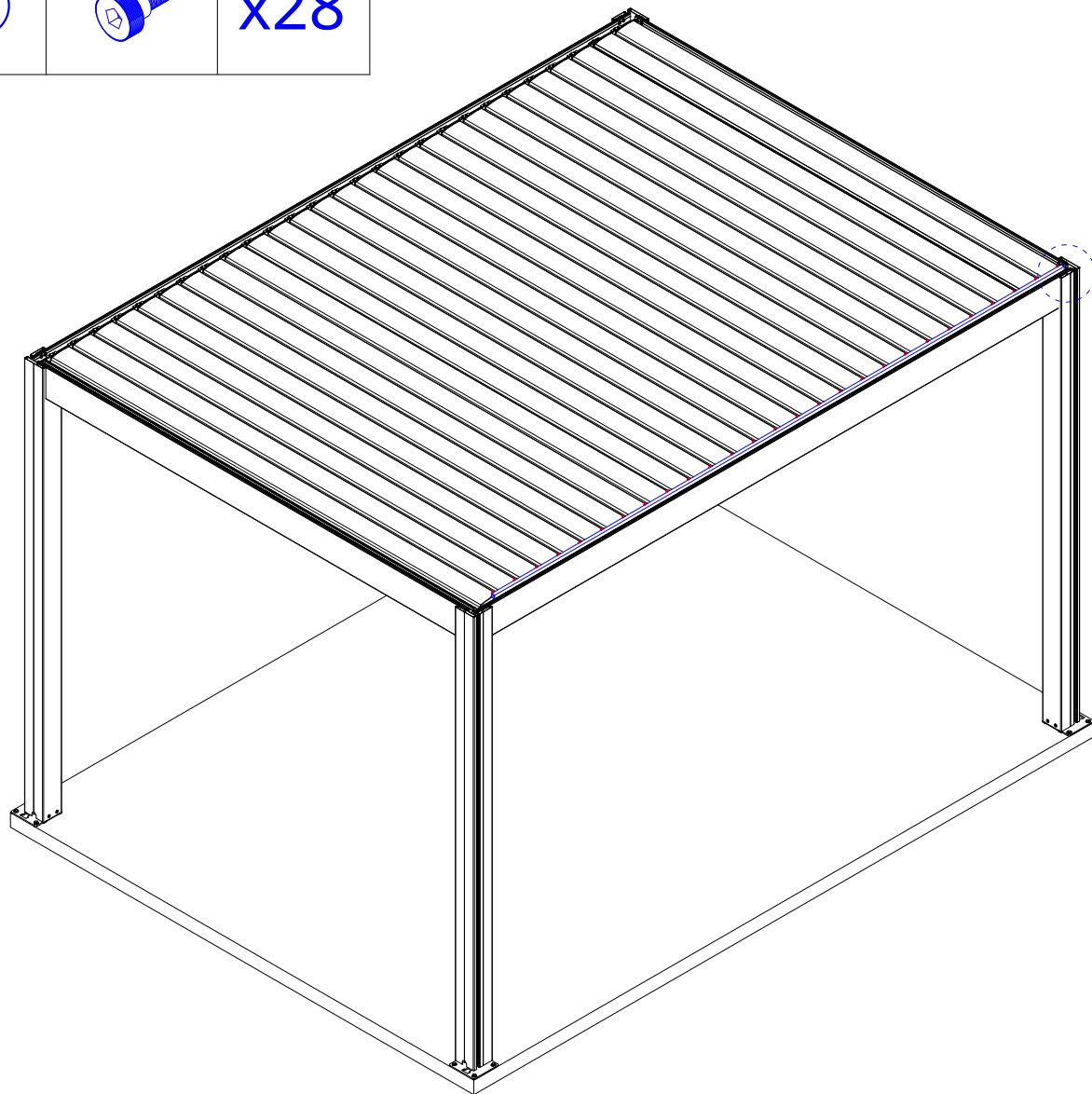

Passo 1

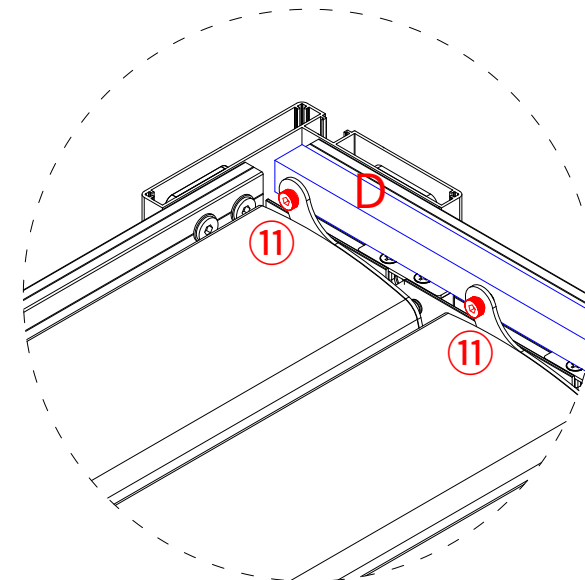

Passo 2

E



x4

Correggere la copertura dello slot a T

1) Come mostrato, inserire la copertura della scanalatura a T E nella scanalatura del montante.

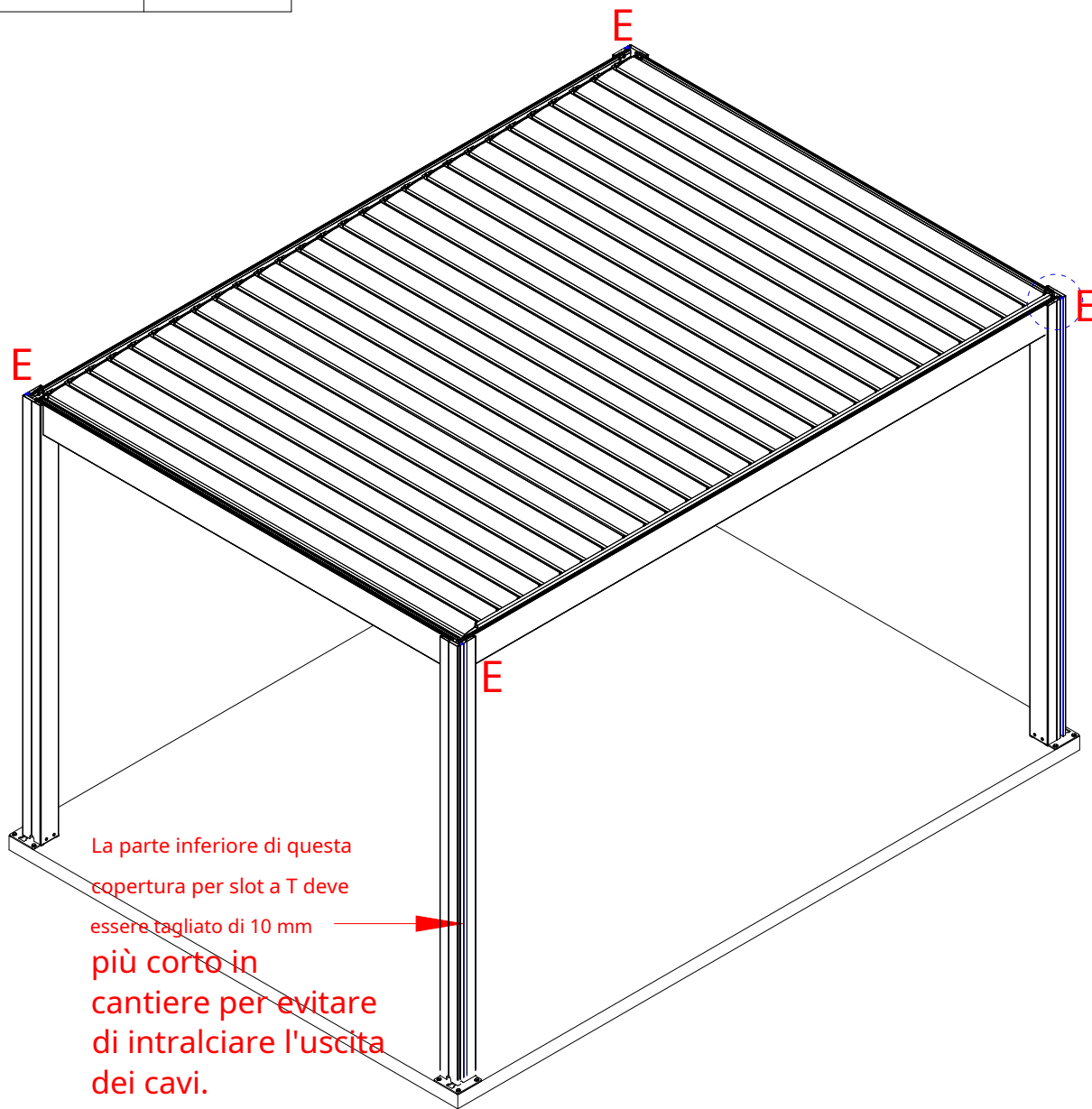

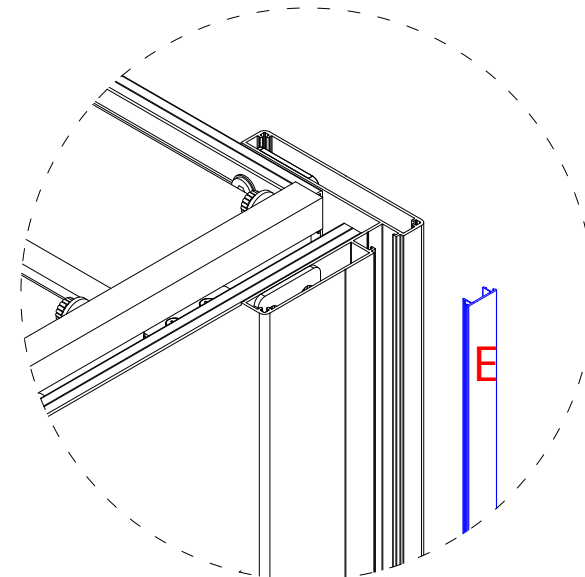

La parte inferiore di questa
copertura per slot a T deve
essere tagliato di 10 mm
più corto in
cantiere per evitare
di intralciare l'uscita
dei cavi.

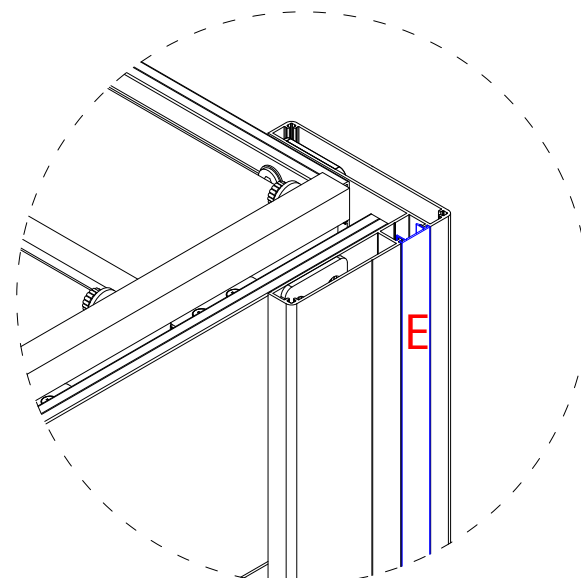

Passo 1

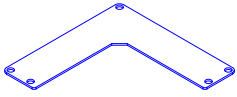

Passo 2

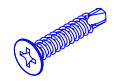
12		x4
13		x12
15		x8

Fissare la copertura superiore del palo

2) Come mostrato, posizionare la piastra del cappuccio terminale a forma di L¹² sulla parte superiore del palo e poi fissarlo con 3 viti autofilettanti da 4,2*16¹³ e 2 viti a coda di trapano da 4,2 * 19¹⁵.

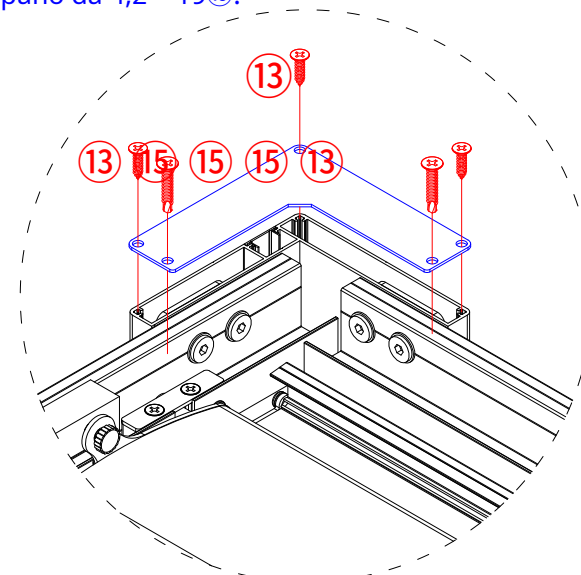
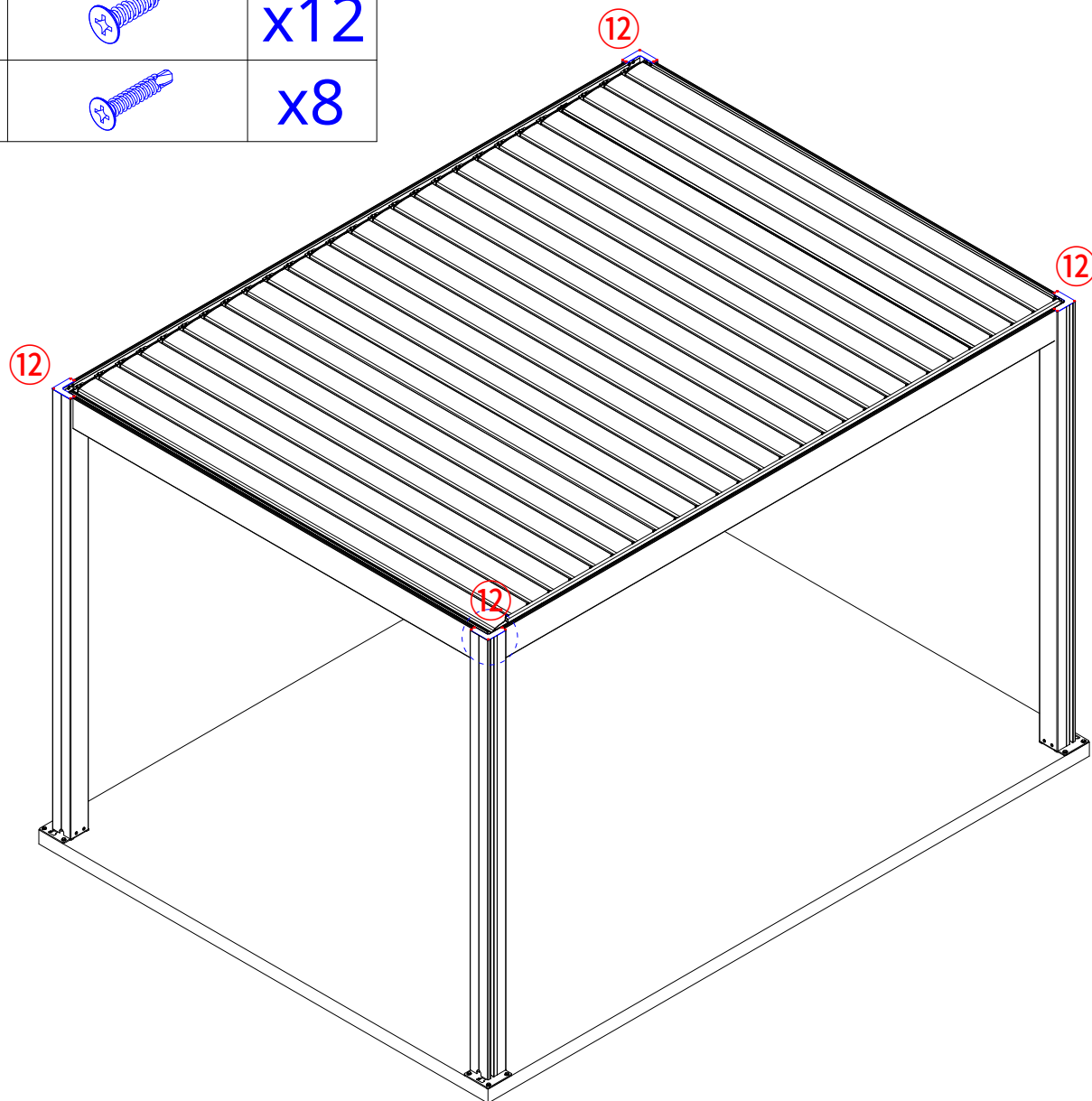

Passo 1

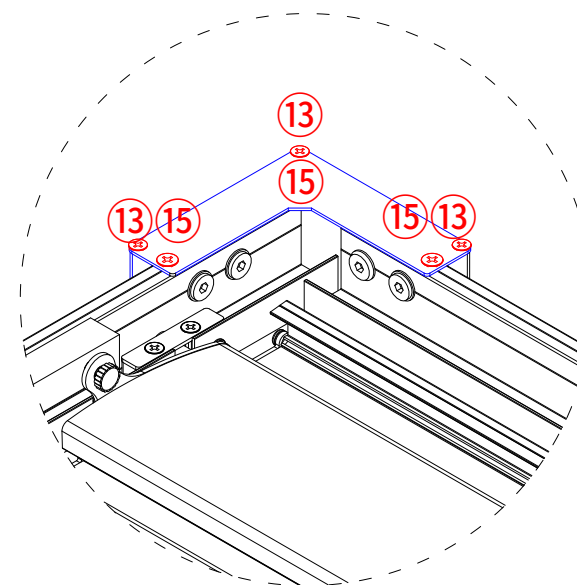

Passo 2

2

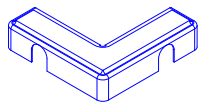

x4

Installazione della copertura della piastra di base

1) Come mostrato, la tacca a forma di U del coperchio della piastra di base deve essere orientata nella stessa direzione dell'apertura di scarico. Il coperchio della piastra di base sul montante con tacca di uscita extra.

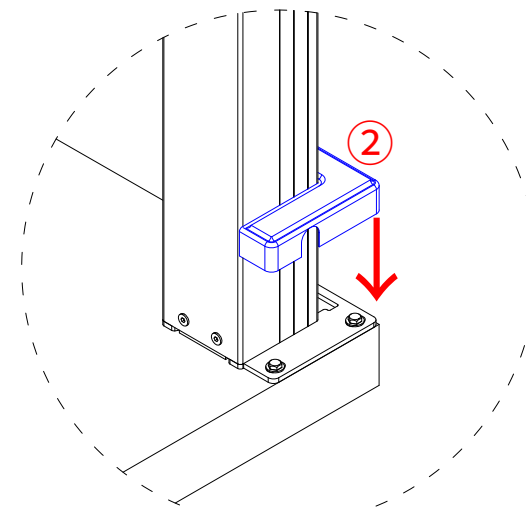
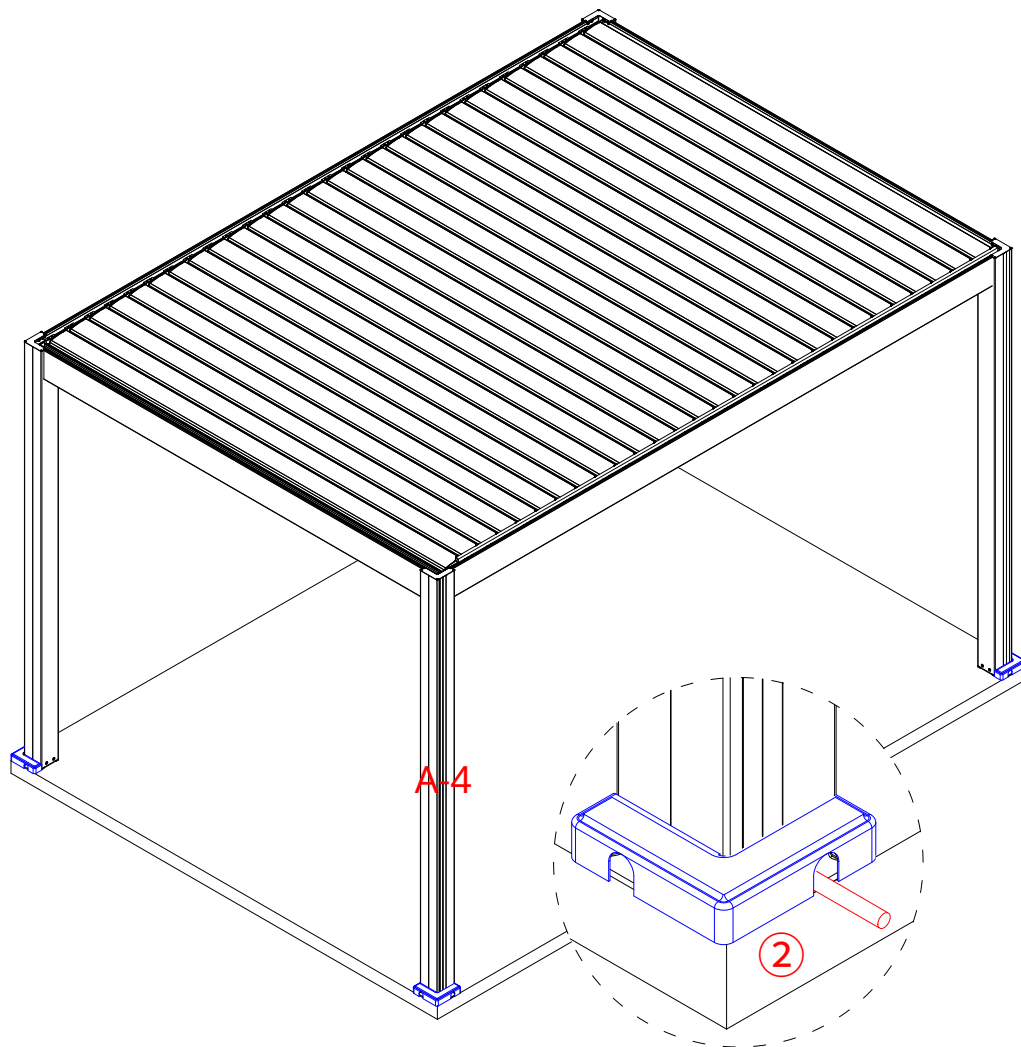

Passo 1

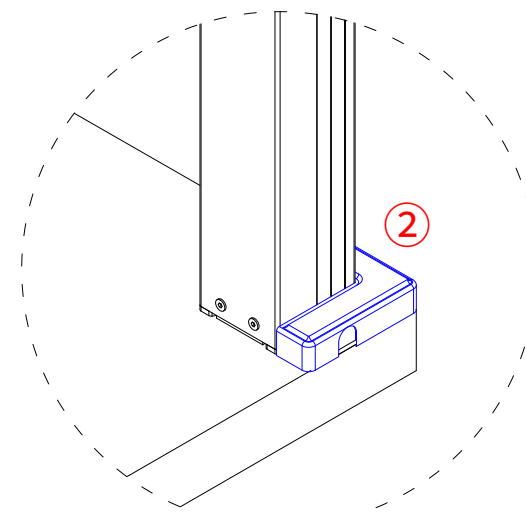

Passo 2

Quando il telecomando e il ricevitore non riescono a controllare il motore, seguire i passaggi seguenti per riprogrammare.

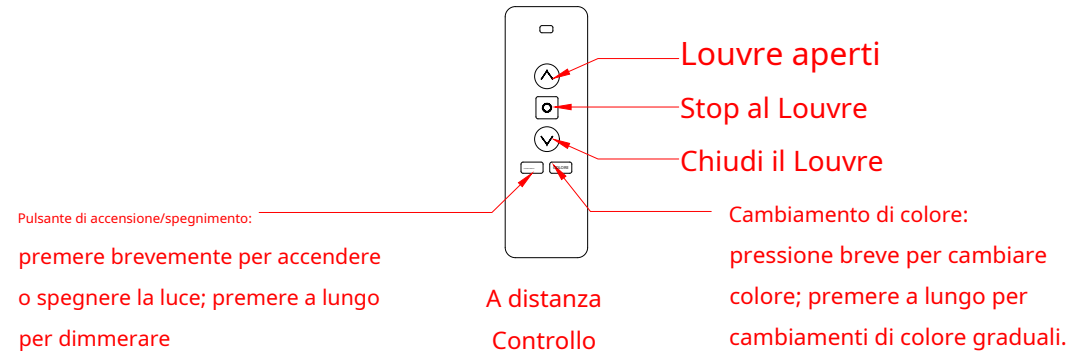

Passaggi per l'accoppiamento:

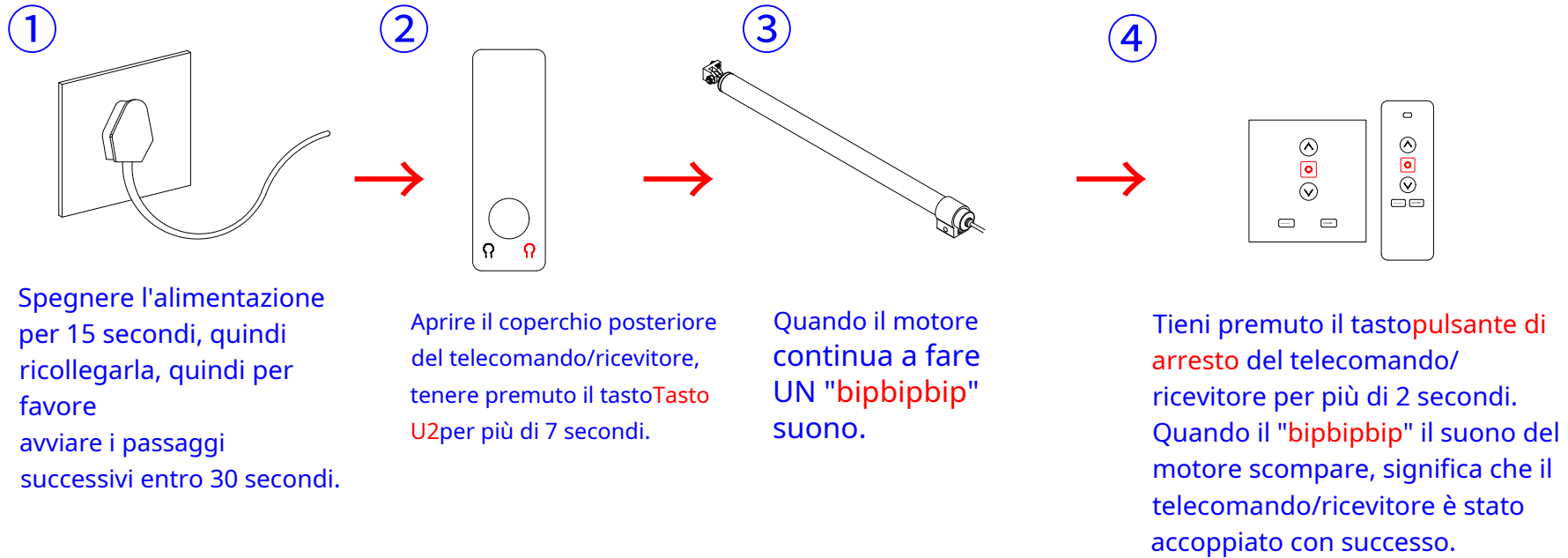

Passaggi di cambio di direzione:

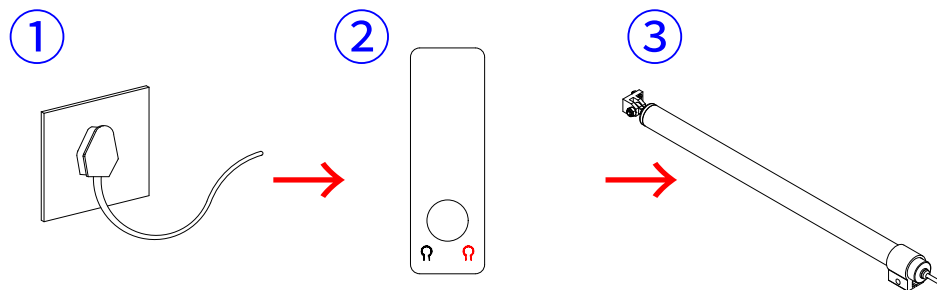

Spegnere l'alimentazione per 15 secondi e quindi ricollegarla il potere, quindi per favore avvia il seguenti passaggi all'interno 30 secondi.

Aprire il coperchio posteriore del telecomando/ricevitore, tenere premuto il **Tasto U2** per più di 7 secondi.

Quando il motore continua a fare UN "bipbipbip" suono.

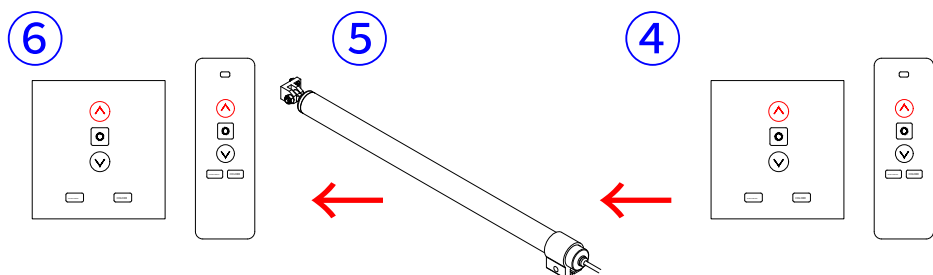

Tieni premuto il **tasto pulsante sudel** telecomando per più di 2 secondi.

Il motore fa UN "bipbipbip" suona di nuovo

Tieni premuto il **tasto pulsante sudel** telecomando/ricevitore per più di 2 secondi.

Passaggi per l'eliminazione dell'associazione:

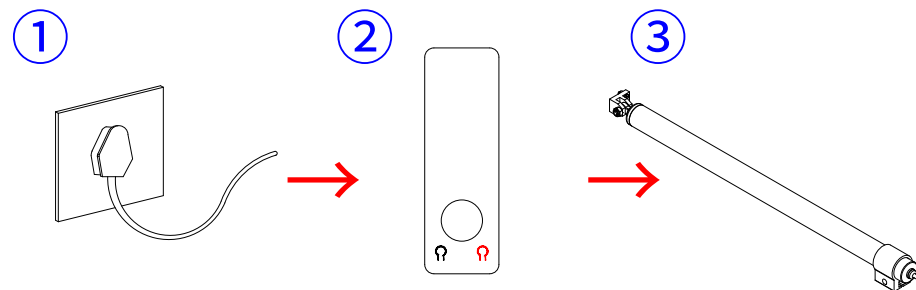

Spegnere l'alimentazione per 15 secondi e quindi ricollegarla il potere, quindi per favore avvia il seguenti passaggi all'interno 30 secondi.

Aprire il coperchio posteriore del telecomando/ricevitore, tenere premuto il **Tasto U2** per più di 7 secondi.

Quando il motore continua a fare UN "bipbipbip" suono.

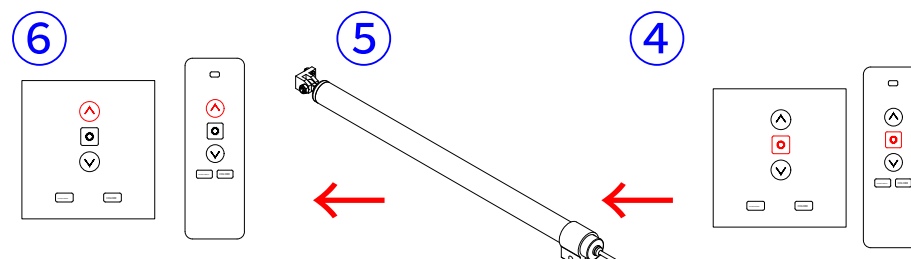

Tieni premuto il **tasto pulsante sudel** telecomando/ricevitore per più di 2 secondi. Elimina l'abbinamento con successo.

Il motore fa UN "bipbipbip" suona di nuovo

Tieni premuto il **tasto pulsante di arresto** del telecomando/ricevitore per più di 2 secondi.

Prenditi cura della tua pergola

Le superfici della struttura rivestite con vernici a polveri termoindurenti devono essere pulite una volta all'anno per mantenere l'aspetto estetico originale.

Le polveri termoindurenti sono sensibili a:

- Attrito fisico, impatto violento, estrusione, sostanze chimiche inclusi solventi alcalini e solventi acidi.
- Elementi naturali come vento, pioggia, neve e luce solare prolungata. L'esterno della pergola potrebbe deteriorarsi nel tempo e questo non sarà coperto dalla garanzia.

Pulire la Pergola

- Non utilizzare spugnette abrasive, creme detergenti, spugne abrasive, sfere di filo di ferro o panni colorati.
- Consigliato: spugna morbida, panno morbido senza sabbia, cotone idrofilo, cotone o carta non tessuta (solo bianca).
- Non utilizzare prodotti corrosivi come detergenti acidi o alcalini. Si consiglia di lavare con acqua detergente a pH neutro e poi asciugarlo con un panno per mantenerlo asciutto.
- Quando si pulisce con un'attrezzatura ad alta pressione, è necessario adottare le stesse precauzioni della pulizia della carrozzeria dell'auto: è necessario considerare la distanza, il tipo di ugello, la temperatura e la pressione dell'acqua.

Usa promemoria

- Al termine dell'installazione, verificare che le viti siano serrate. Ricordarsi di controllare le viti almeno una volta all'anno.
- **Nel caso in cui siano previste nevicate, grandine o forti venti superiori a 80 km/h, si consiglia di aprire le lamelle della feritoia. Non azionare le lame in caso di gelo o neve. Si prega di togliere le lame dalla pergola quando la neve è abbondante.**
- Controllare regolarmente le condizioni di tenuta per garantire che le guarnizioni o altri componenti non perdano.
- Pulire regolarmente i detriti come le foglie cadute sulla pergola per evitare il blocco dello scarico.
- Restrizioni d'uso: I sistemi a tenuta stagna, pur essendo efficaci, non sono progettati per garantire la completa impermeabilità. Forti piogge e forti venti possono danneggiare la pergola. Eventuali danni subiti non saranno coperti dalla garanzia.

GEbruikersHANDLEIDING

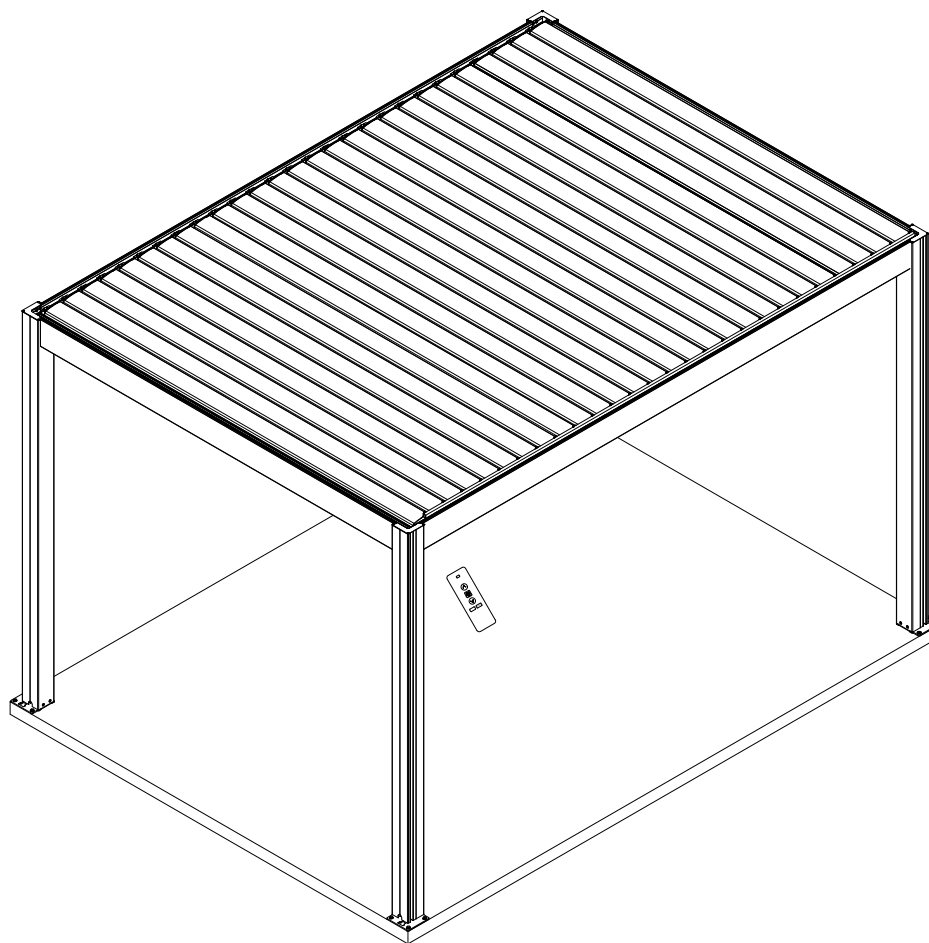

OTHER LANGUAGES

Pergola 4x2,86M

Lees deze handleiding voordat u uw pergola voor de eerste keer gebruikt.
Bewaar deze handleiding voor toekomstig gebruik.

Pergola

Opening: Elektrisch

Maat: 295,3(Lengte) x 409(Breedte) -cm

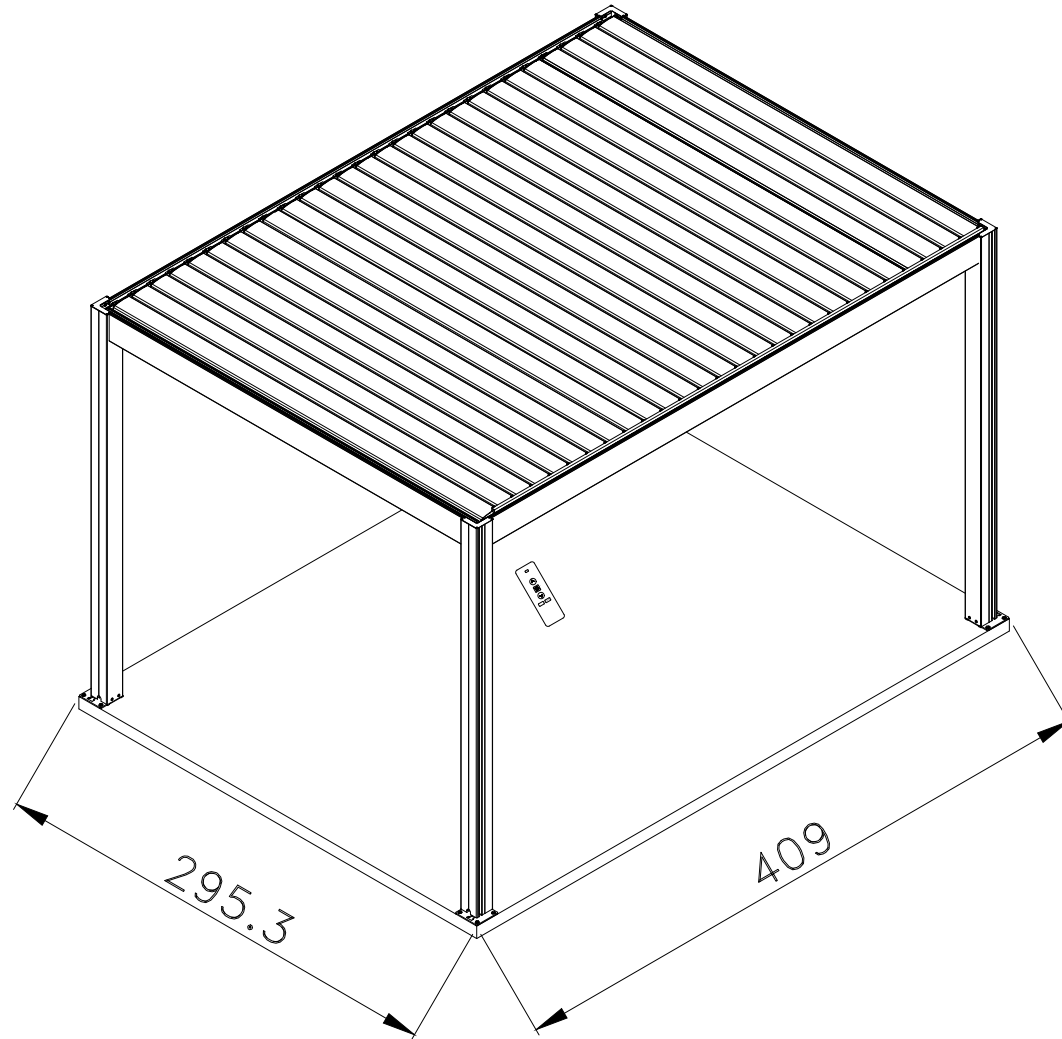

Gebruikshandleiding:

1. Voor de installatie zijn minimaal drie personen nodig: één voor het meten en markeren, één voor de installatie en één als assistent.
2. Er worden alleen betonvloerbevestigingen meegeleverd. In het geval dat er geen betonplaat op de grond ligt, wordt aanbevolen om bij elke kolom betonplaten te maken. De betonplaat moet minimaal zijn 500x500x500mm.
3. Nadat het pergolaframe is gemonteerd, gebruikt u een vierkant, waterpas en liniaal om het product waterpas en diagonaal te meten om de grootte van de pergola te garanderen. De basis moet precies waterpas zijn, zonder tolerantie.
4. De pergola moet aan de vloer worden vastgeschroefd. Wij nemen er geen verantwoordelijkheid als tegels barsten tijdens het boren van de bouten.
5. Elektrisch gereedschap is vereist: zorg ervoor dat het goed werkt en volg de veiligheidsinstructies.
6. Wees voorzichtig bij het gebruik van scherp gereedschap.
7. Draag beschermende kleding, inclusief een veiligheidsbril, helm en handschoenen.
8. Klim of sta niet op het dak.

Veiligheidswaarschuwing

- . Het wordt ten zeerste aanbevolen om tijdens de montage handschoenen te dragen.
- . Installeer een pergola niet tijdens slechte weersomstandigheden, zoals wind of regen.
- . Raak geen draden aan met aluminium profielen.
- . Draag altijd beschermende schoenen en een bril wanneer u een pergola installeert.
- . Houd alle plastic zakken buiten het bereik van kinderen.
- . De pergolakolom moet op een vlakke ondergrond worden geplaatst en bevestigd.
- . Leun tijdens de montagefase niet op de kolom.
- . Laat kinderen tijdens de montagefase de locatie niet naderen.
- . Wees niet in de buurt van de pergola tijdens een storm of tyfoon.
- . Probeer niet pergola te beklimmen onder invloed van alcohol of drugs.
- . Wanneer u tijdens de montagefase ladders of soortgelijk gereedschap en elektrisch gereedschap gebruikt, dient u de veiligheidsaanbevelingen van de fabrikant op te volgen.
- . Elk heet gereedschap, zoals een elektrische boormachine, mag niet in contact komen met het pergolaprofiel.
- . Zorg ervoor dat er geen kabels of andere kabels ondergronds verborgen zitten voordat u de kolom plaatst.

Algemeen advies

- . Deze pergola bestaat uit verschillende onderdelen en de montage duurt minimaal 90 minuten. De pergola mag niet onder een boom worden geplaatst.
- . Als u de kolom rechtstreeks op cement of een soortgelijke basis aansluit, gebruik dan de voorgeperforeerde gaten in de meegeleverde basis.
- . Controleer vóór montage het aantal profielen en hulpstukken en gebruik ze volgens de lijst met profielbeslag voor een eenvoudige montage.
- . Doe kleine stukjes, zoals schroeven, in een bakje om verlies te voorkomen.
- . Let op de positie van de transmissie op de balk om verkeerde plaatsing te voorkomen.
- . Verwijder regelmatig bladeren, sneeuw of andere voorwerpen van de pergola.

Onderhoud en reparatie

- . Om de pergola schoon te maken, gebruikt u een mild schoonmaakmiddel en spoelt u af met water. Gebruik geen aceton of schurende schoonmaakmiddelen om het oppervlak van het aluminium profiel schoon te maken.

Garantie

- . De algemene garantie op verkleuring bedraagt 5 jaar, voor de motor en de LED-verlichting 2 jaar.

Beschermings- en installatiehulpmiddelen

Beschermende uitrusting:

1. Helm
2. Handschoenen
3. EHBO-doos
4. Veiligheidsbril



Meetinstrument:

1. Meetlint (5 meter of meer)
2. Vierkante liniaal
3. Niveau

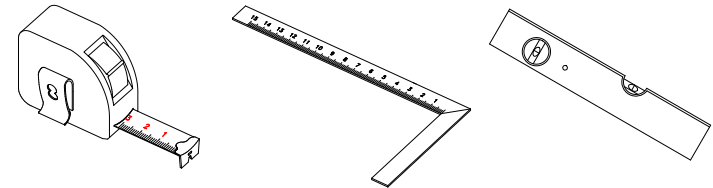



Hulpmiddelen:



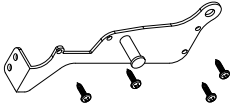
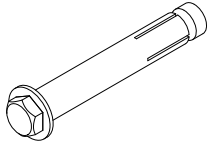
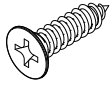
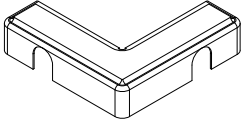
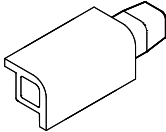
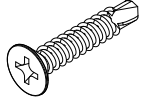
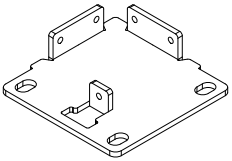
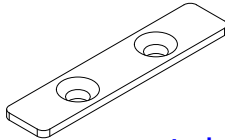
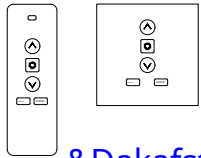
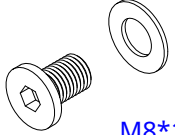

1. Ladder van 2 meter (1,5 meter of meer)
2. 13 mm inbussleutel
3. 17 mm inbussleutel
4. Elektrische boormachine
5. Elektrische boor (10 mm boor)
6. Marker of potlood
7. Rubberen hamer
8. Afdichtmiddel en lijmpistool

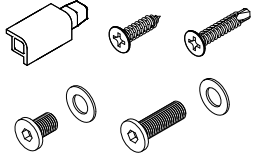
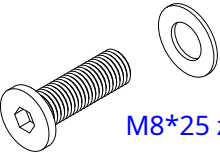
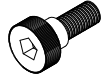
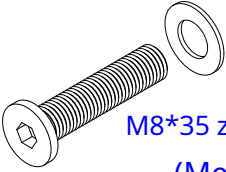
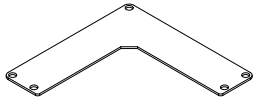

Lijst met accessoires en schroeven

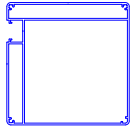
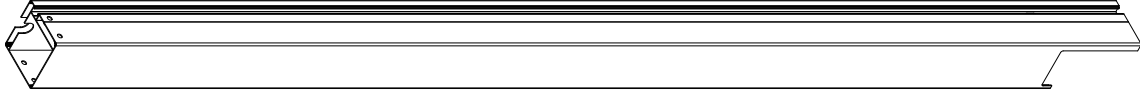
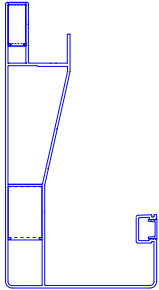
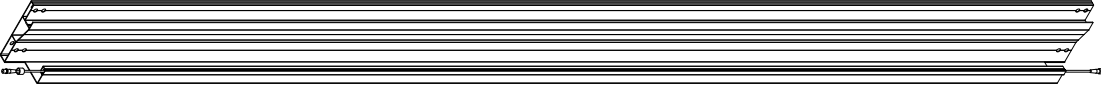
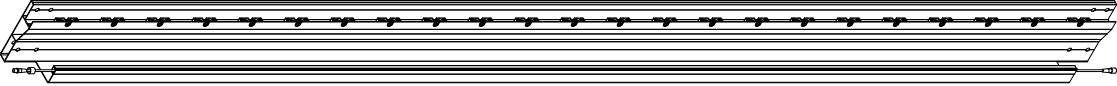
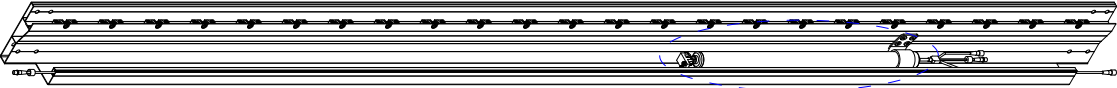
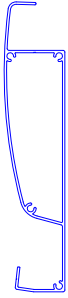
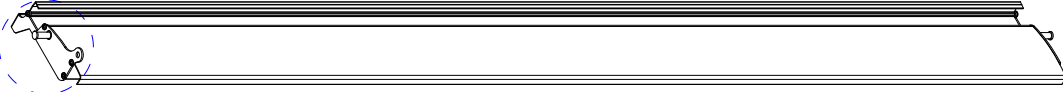
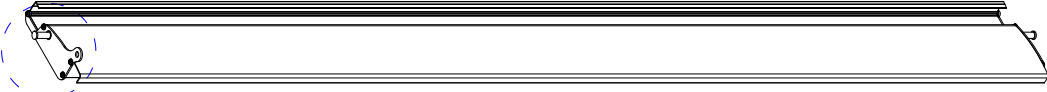
<p>①</p>	 <p>x 1 Eindkap tbv Matoraansluitrooster en 4*20 schroeven met platte kop</p>		<p>⑦</p>	 <p>x 16 M8*80 Expansieschroef</p>		<p>⑬</p>	 <p>x 12 4,2*16 platte kopschroef</p>
<p>②</p>	 <p>x 4 Bodemplaatafdekking</p>		<p>⑧</p>	 <p>x 4 Posthoek Verlengstuk</p>		<p>⑭</p>	 <p>x 8 4,2*19 boorschroef</p>
<p>③</p>	 <p>x 4 Basisplaat</p>		<p>⑨</p>	 <p>x 56 Ashouderdop</p>		<p>⑮</p>	 <p>x 1 Ontvanger & Dakafstandsbediening</p>
<p>④</p>	 <p>x 16 M8*12 zeskantschroeven (Met wasmachine)</p>		<p>⑩</p>	 <p>x 112 M5*16 Verzonken schroef</p>		<p>⑯</p>	 <p>x 1 Reserveonderdelen</p>
<p>⑤</p>	 <p>x 16 M8*25 zeskantschroeven (Met wasmachine)</p>		<p>⑪</p>	 <p>x 28 M6*5 zeskantduimschroef</p>		<p>⑰</p>	
<p>⑥</p>	 <p>x 16 M8*35 zeskantschroeven (Met wasmachine)</p>		<p>⑫</p>	 <p>x 4 L-stijl bovenklep</p>		<p>⑱</p>	

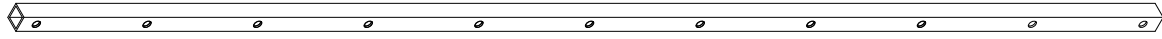
Profiellijst

<p>A-1 ~ A-4</p>			<p>x 4 Na</p>
<p>B-2 B-4</p>			<p>x 2 Balk & Goot</p>
<p>B-1</p>			<p>x 1 Balk & Goot (met schachthouder)</p>
<p>B-3</p>			<p>x 1 Balk & Goot (met ashouder) + Motor</p>
<p>C-1</p>			<p>x 1 Motorverbindingslouvre</p>
<p>C-2</p>			<p>x 27 Louvre</p>
<p>D</p>			<p>x 1 Stuurstang</p>
<p>E</p>			<p>x 4 T-sleufafdekking</p>

Aluminium profielen lay-out tekening

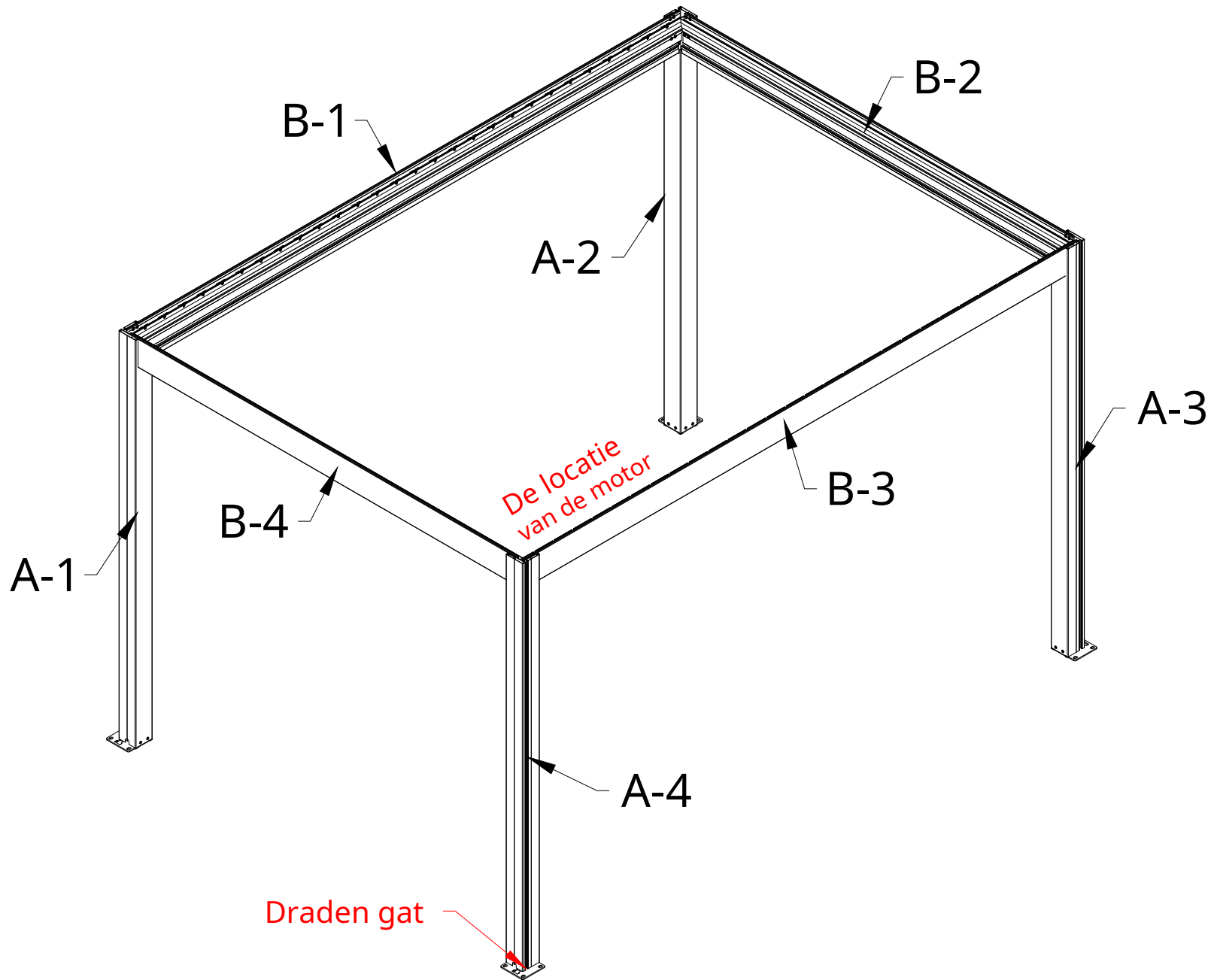

1

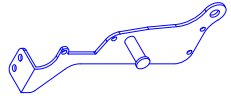

x 1



x 4

Motorverbindingslouvre installeren

1) Bevestig de mesafdekking op het motorverbindingsrooster C-1 met 4*20 schroeven met platte kop.

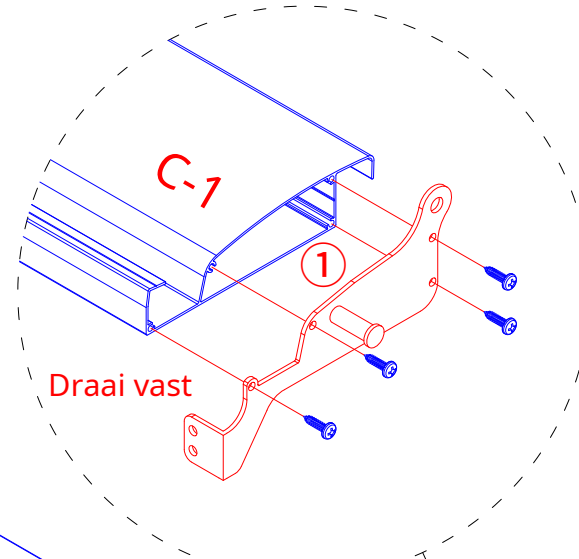

Stap 1

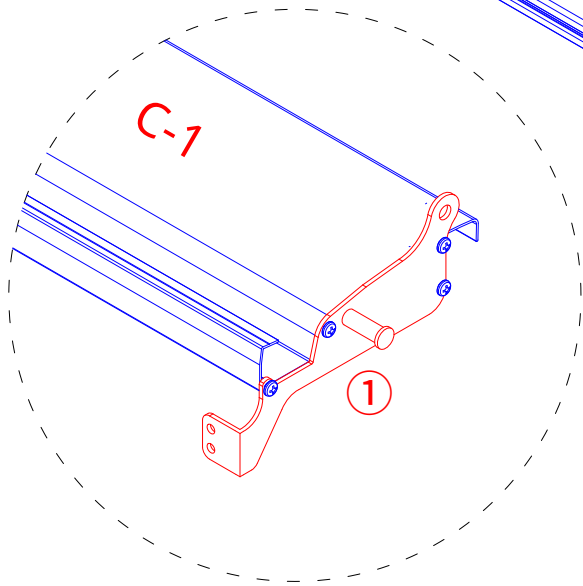

Stap 2

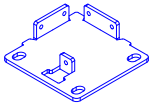
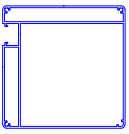
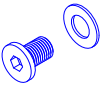

Als de installatieplaats krap is, kunnen de mesafdekkingen worden geïnstalleerd nadat het frame is geïnstalleerd.

③		x 4	A-1		x 4
④		x 16	A-4		

Monteer het raamwerk

1) Plaats het deksel van de basisplaat zoals afgebeeld ② in de posten, Lijn vervolgens de gaten in de basisplaat uit ③ met de gaten in de palen en vergrendel de basisplaat ③ aan de palen met de M8 * 12 zeskantschroeven (met sluitring) ④.

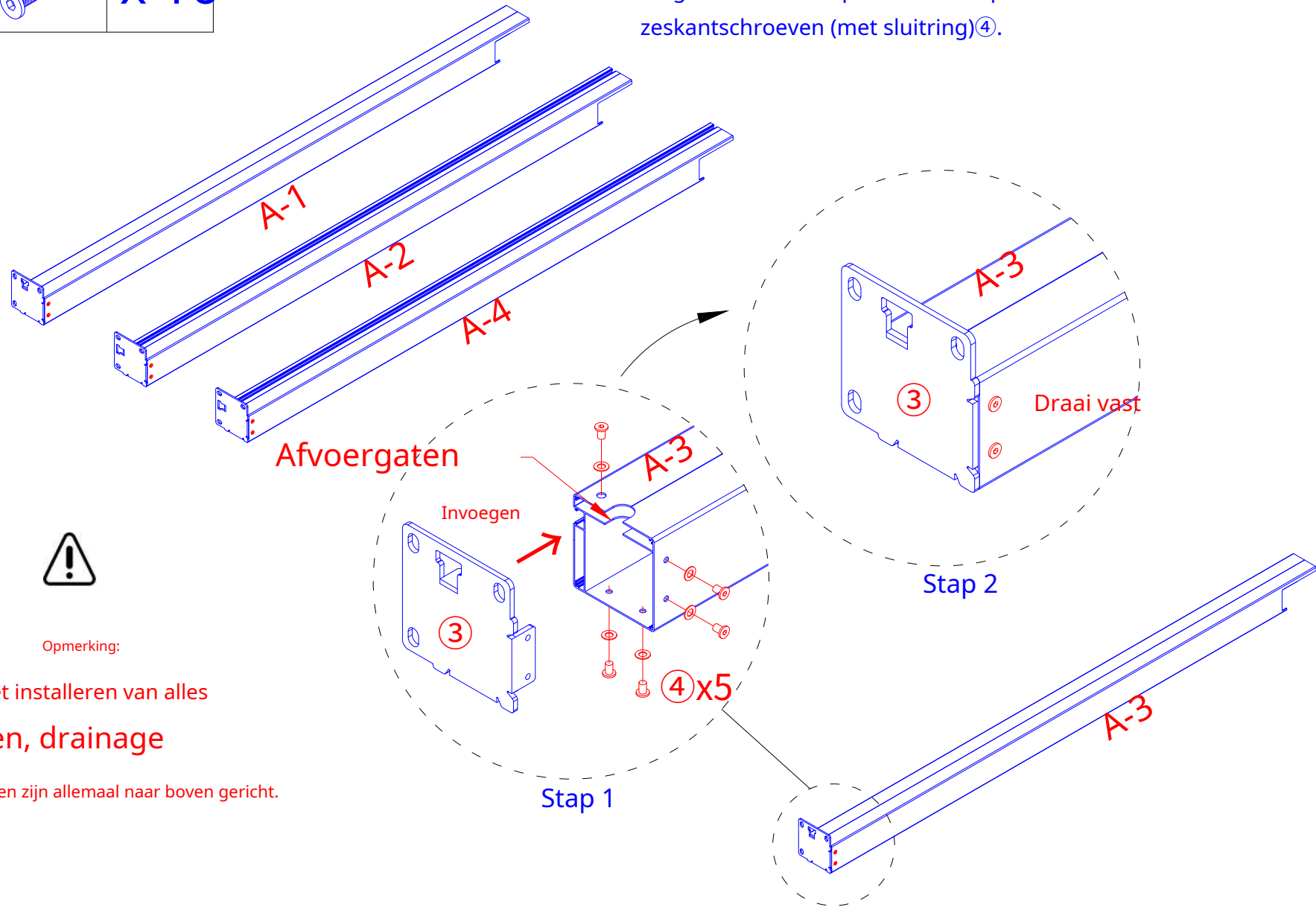

Opmerking:

Bij het installeren van alles
palen, drainage

De gaten zijn allemaal naar boven gericht.

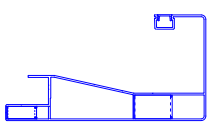
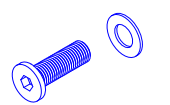
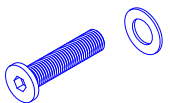
B-1 B-3		x 2
⑤		x 8
⑥		x 8

Monteer het raamwerk

2) Plaats zoals afgebeeld de balk en goot (B-1, B-3) in de posten, repareerde vervolgens de balk en goot (B-1, B-3) op de palen met M8*25 zeskantschroeven⑤ en M8*35 zeskantschroeven⑥.

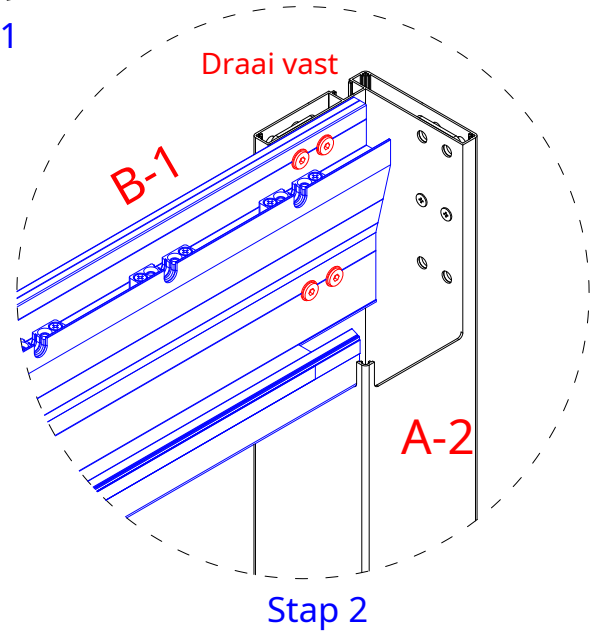
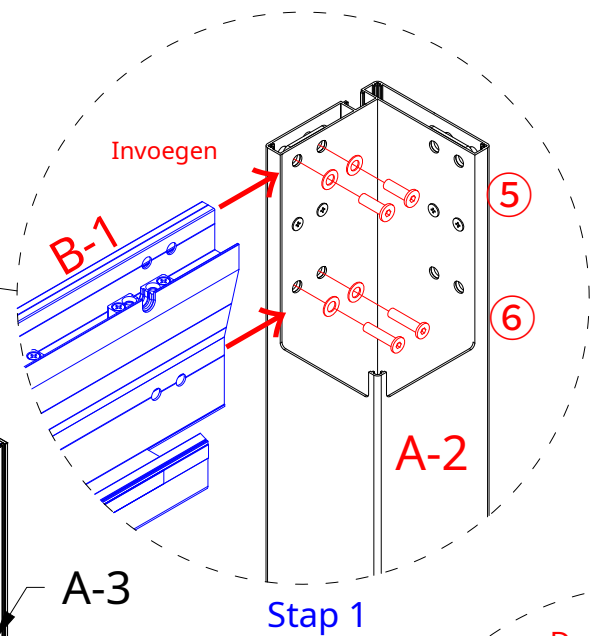
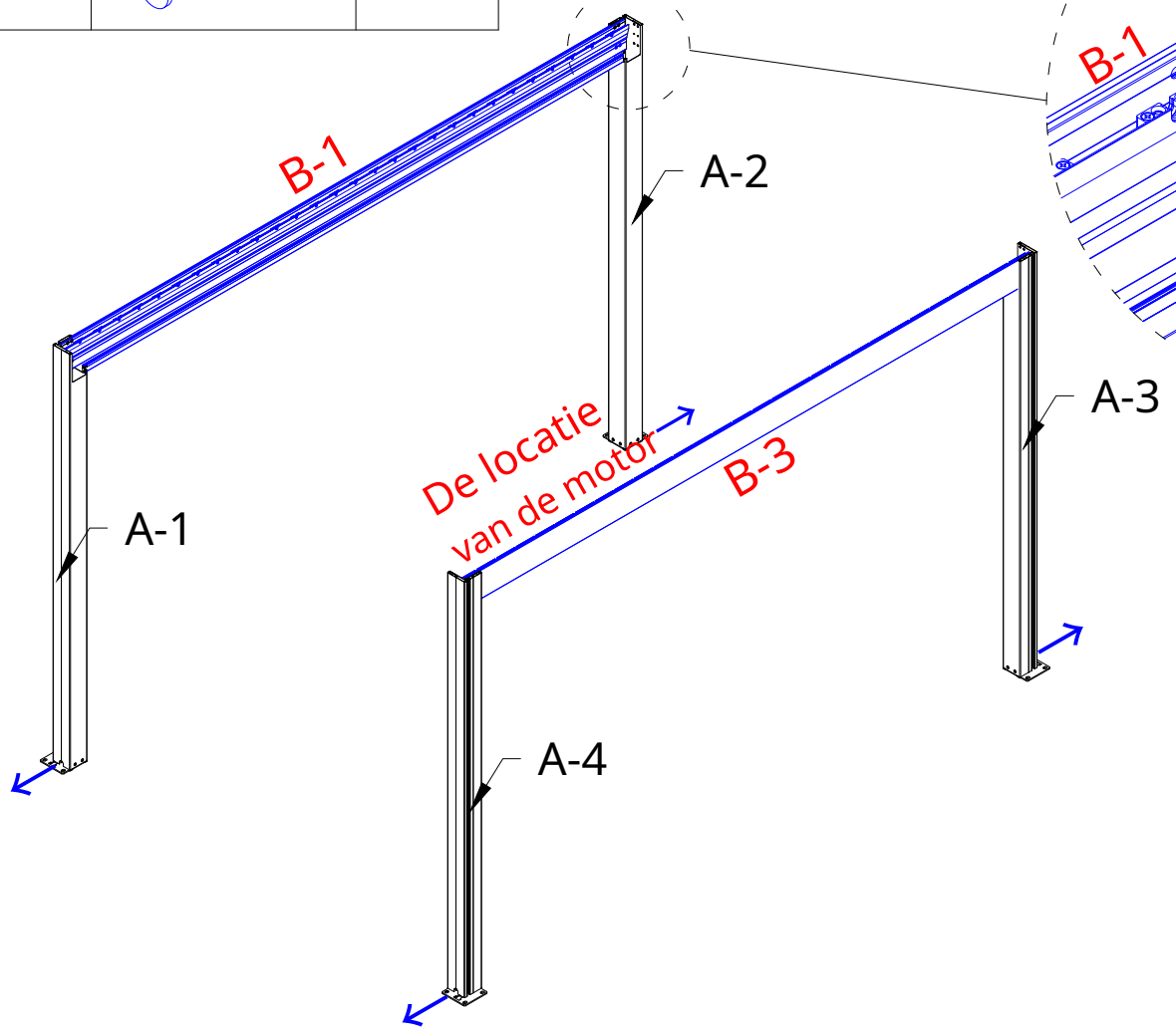

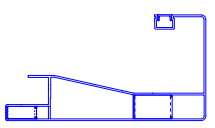
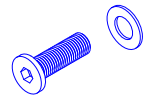
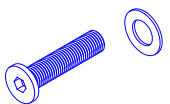
B-2 B-4		x 2
⑤		x 8
⑥		x 8

Monteer het raamwerk

3) Plaats de balk en goot zoals afgebeeld B-2, B-4 in de posten, repareerde vervolgens de balk & goot B-2, B-4 op de palen met M8*25 zeskantschroeven ⑤ en M8*35 zeskantschroeven ⑥.

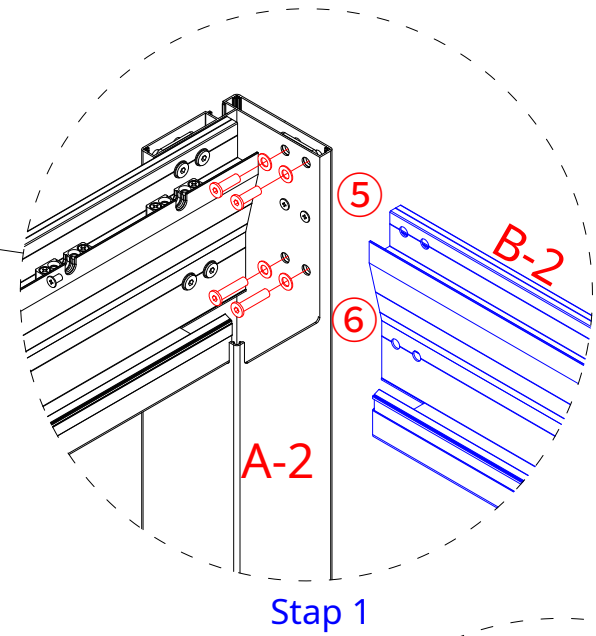
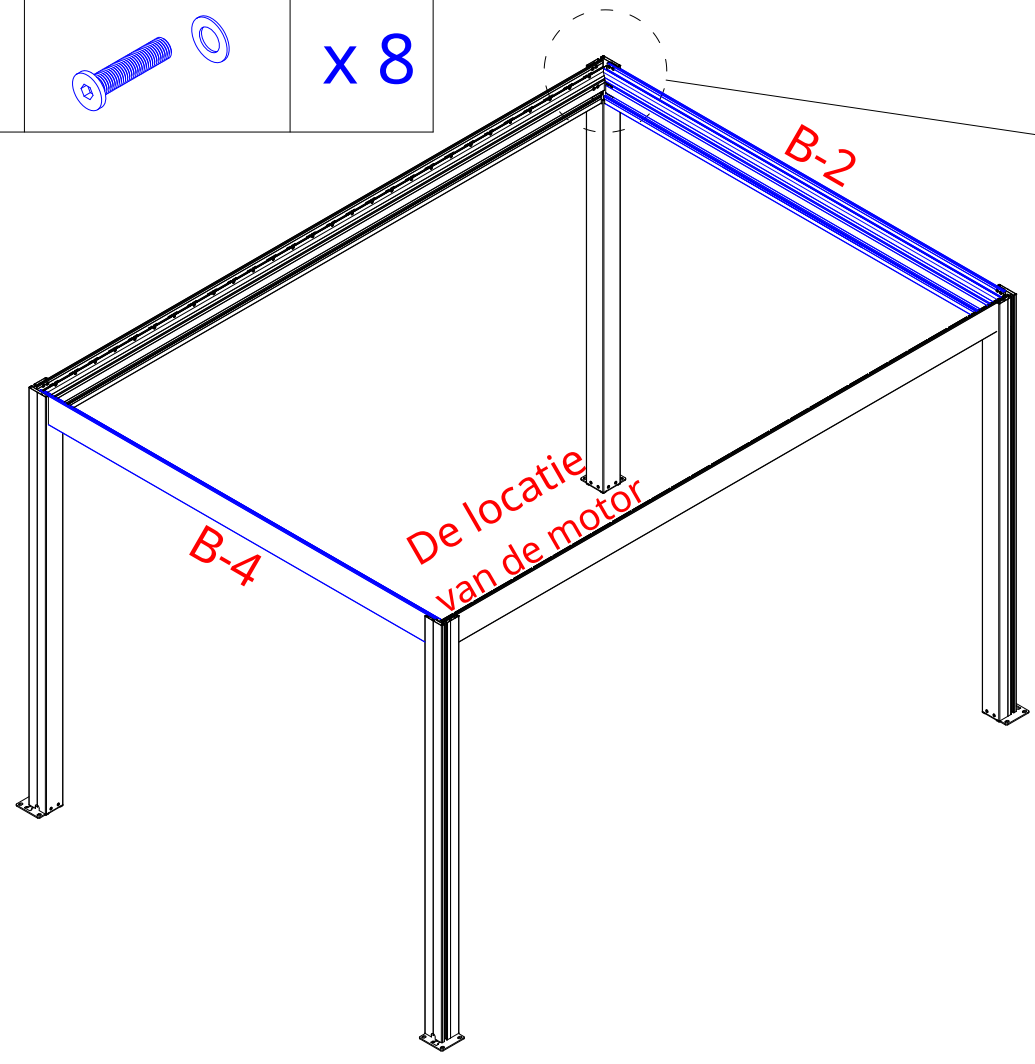

Stap 1

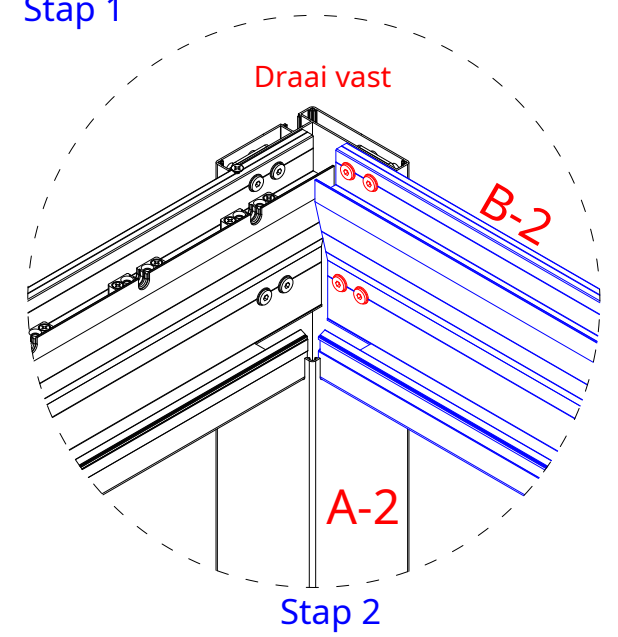

Stap 2

7

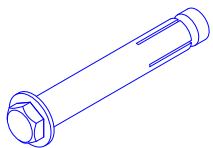

x 12

Opmerking:



Voordat u de basisplaat bevestigt, moet u ervoor zorgen dat de diagonalen van de 4 palen dezelfde lengte hebben. Zorg ervoor dat de maat $W1=W2, W3=W4$ is.

Bevestig de pergola aan de grond

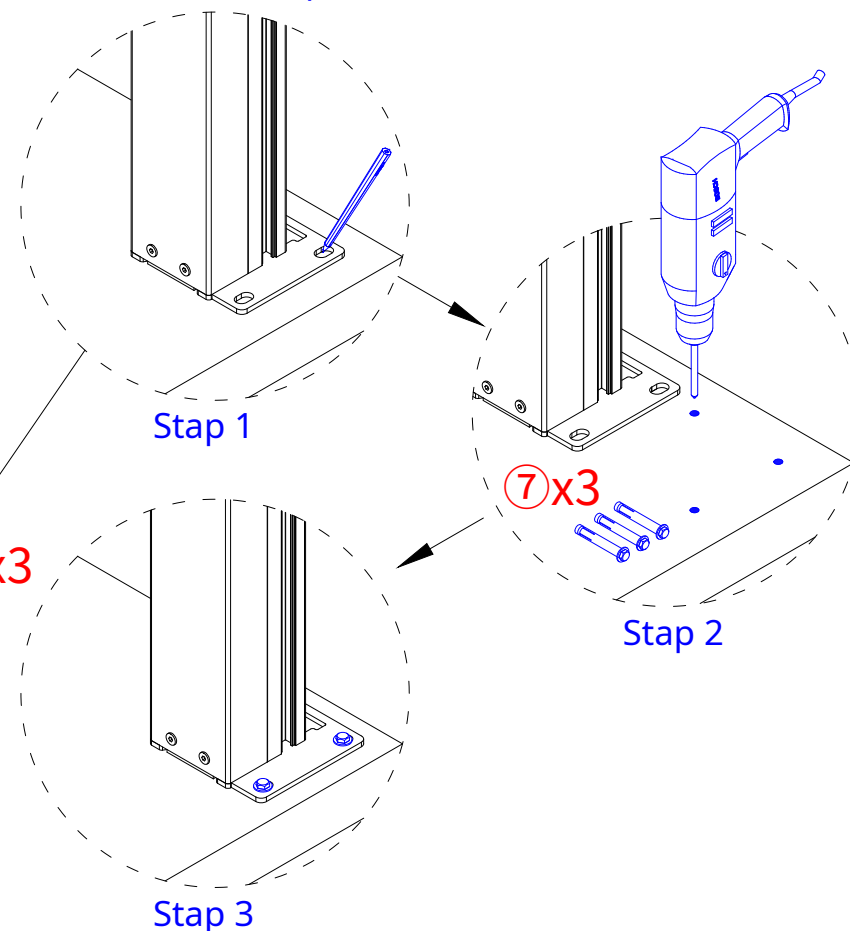
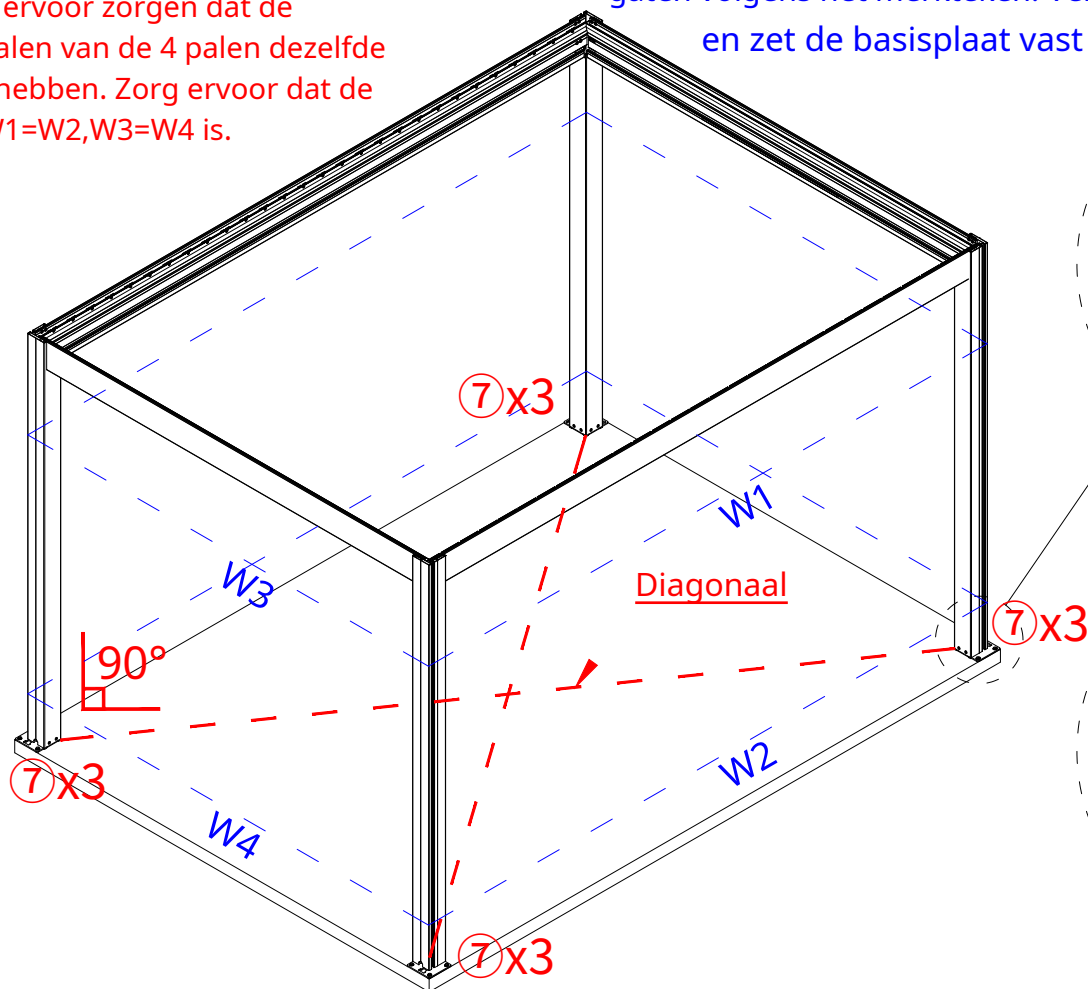
- 1) Gebruik de 12 M8*80 expansieschroeven ⑦ mits de grond een betonnen vloer is. Als dit niet het geval is, moet u een andere oplossing vinden om uw pergola op het gewenste oppervlak te bevestigen.
- 2) Verplaats de pergola naar de juiste installatiepositie, markeer vervolgens de positie van de vier palen met het potlood, verwijder de pergola en gebruik de elektrische boormachine om 12 gaten volgens het merkteken. Verplaats de pergola terug naar de positie en zet de basisplaat vast met de M8*80 expansieschroef ⑦.



Het is de verantwoordelijkheid van de gebruiker om ervoor te zorgen dat de pergola vastgezet wordt. De fabrikant is niet verantwoordelijk voor schade veroorzaakt door natuurrampen of speciale gebeurtenissen aan de pergola (of de accessoires ervan). Elke pergola die niet is bevestigd, kan wegwaaien en schade veroorzaken. Deze verantwoordelijkheid kan niet aan de fabrikant worden toegeschreven. Controleer de pergola regelmatig om er zeker van te zijn dat deze stabiel en stevig op de grond staat. Een pergola die losraakt van zijn plaats en schade oploopt of veroorzaakt, valt niet onder de garantie.

 LED-draad
 Stroomdraad

Het laten lopen van de draden

Wanneer u de draden neerlegt, schuift u ze vanaf de inkeping aan de bovenkant van de paal in de paal, trekt u vervolgens de draden naar het uitlaatgat, trekt u de draden vervolgens uit het stopcontact en komt u ze uiteindelijk uit het gat aan de onderkant van de post.

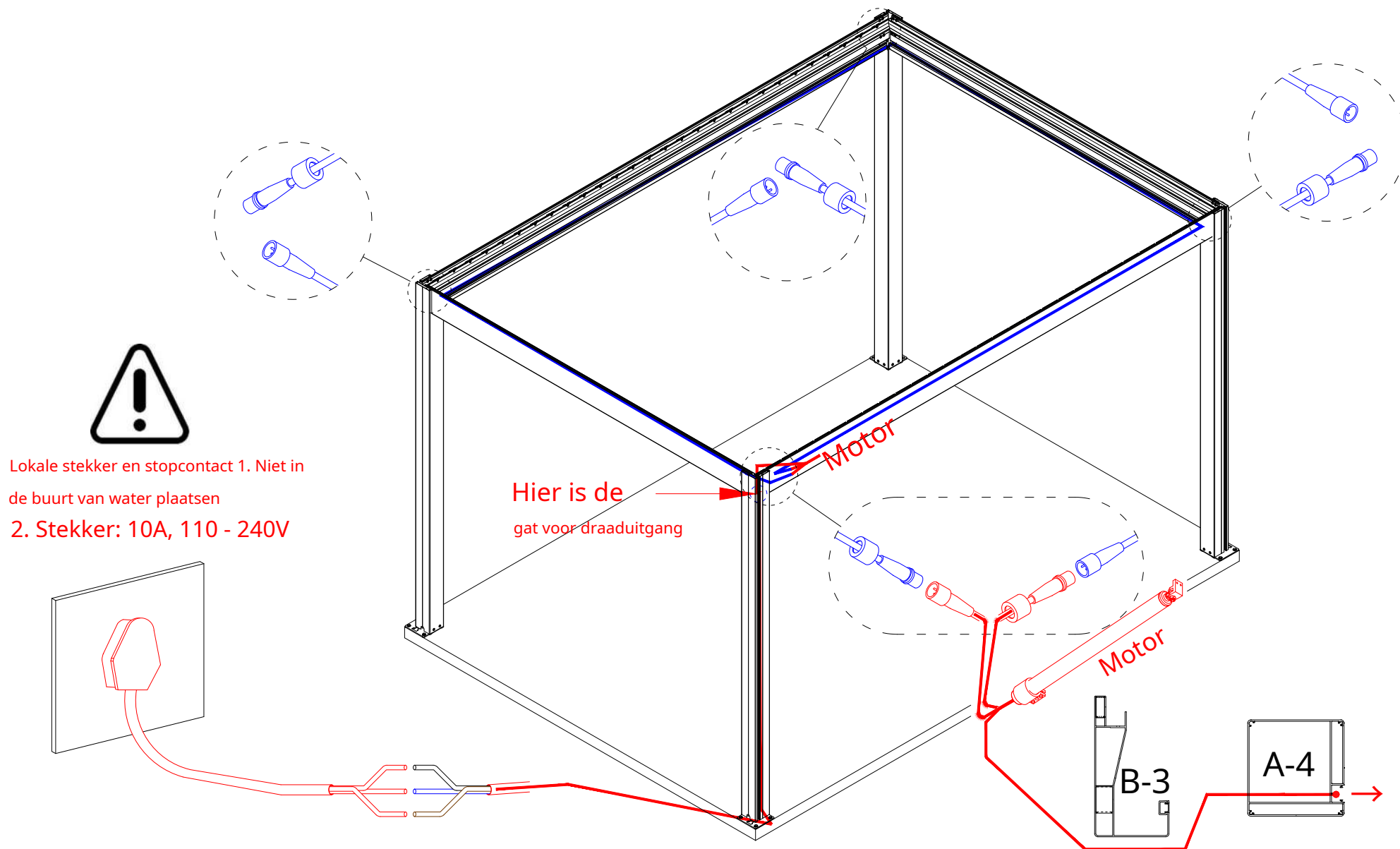



Opmerking: Volg de stappen om de draad correct aan te sluiten, anders zal de motor defect zijn.



De stekker wordt niet meegeleverd

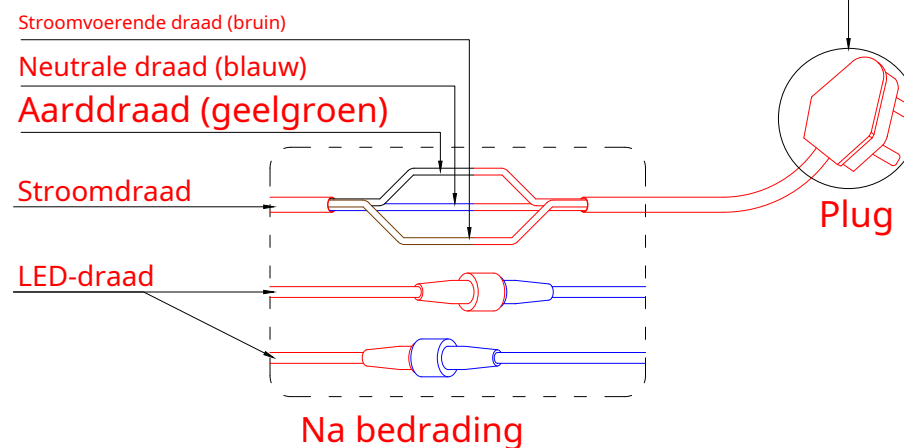
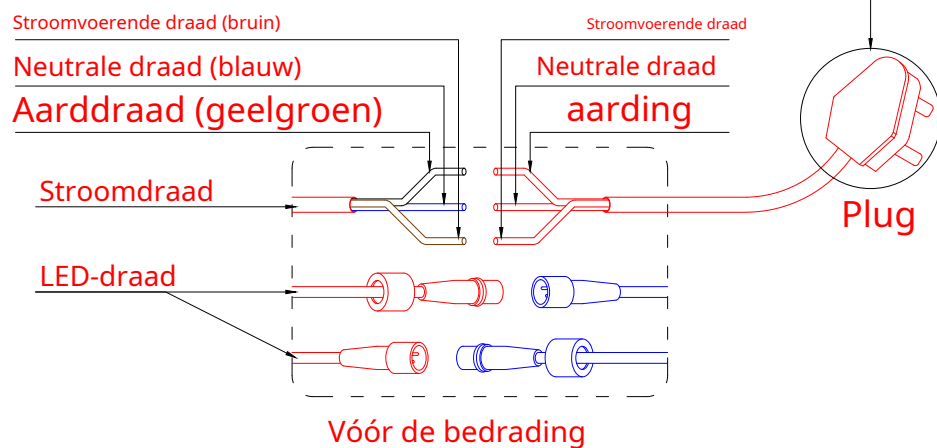

8

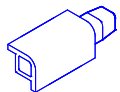

x 4

Bevestig het hoekverlengstuk van de paal

1) Schuif, zoals weergegeven, het verlengstuk van de paalhoek in de bovenkant van de paalhoek.

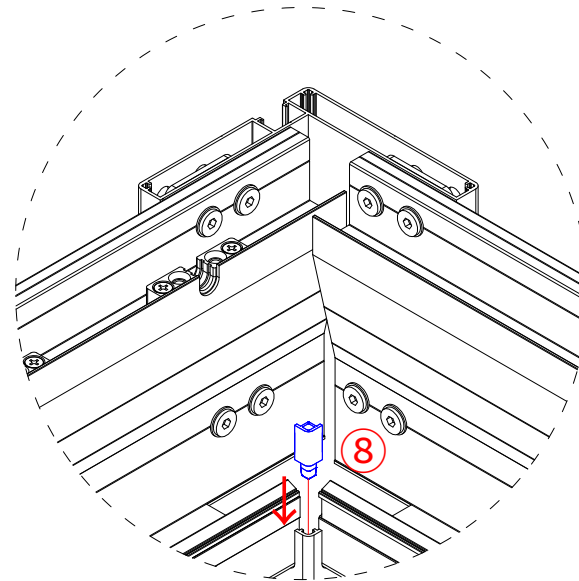
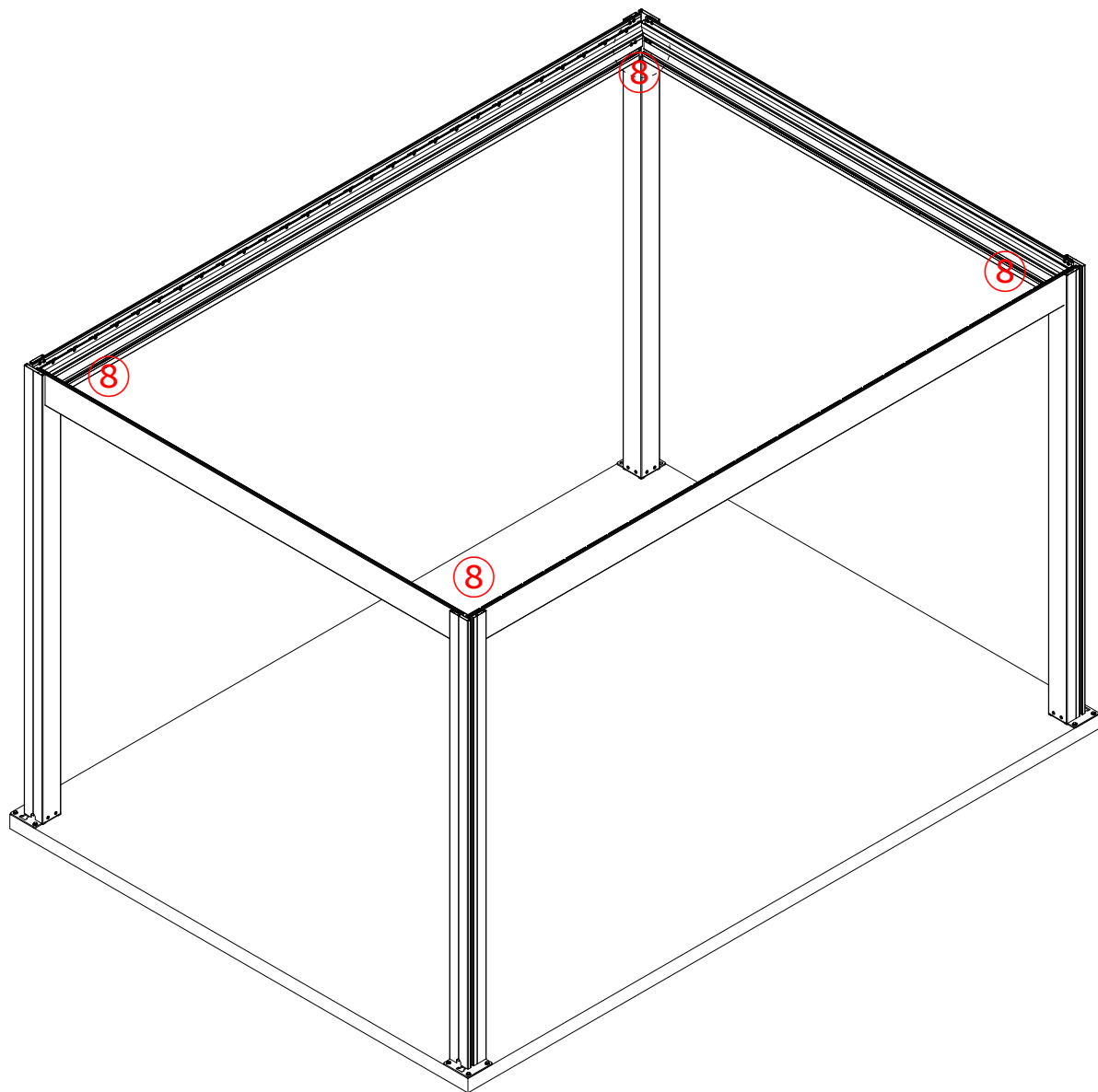

Stap 1

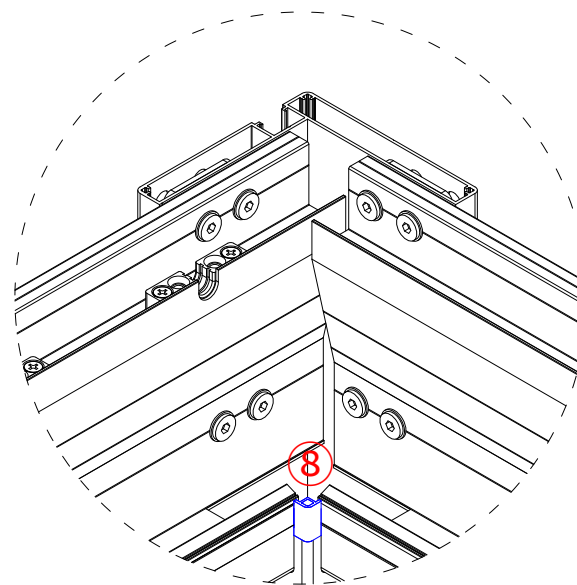

Stap 2

C-1

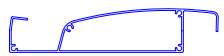

x 1

Louvre installeren

- 1) Zoals weergegeven klikt het motorverbindingsrooster C-1 rechtstreeks in de groef.
- 2) Sluit de motorarmbeugel aan op de eindkap van het motoraansluitrooster C-1.

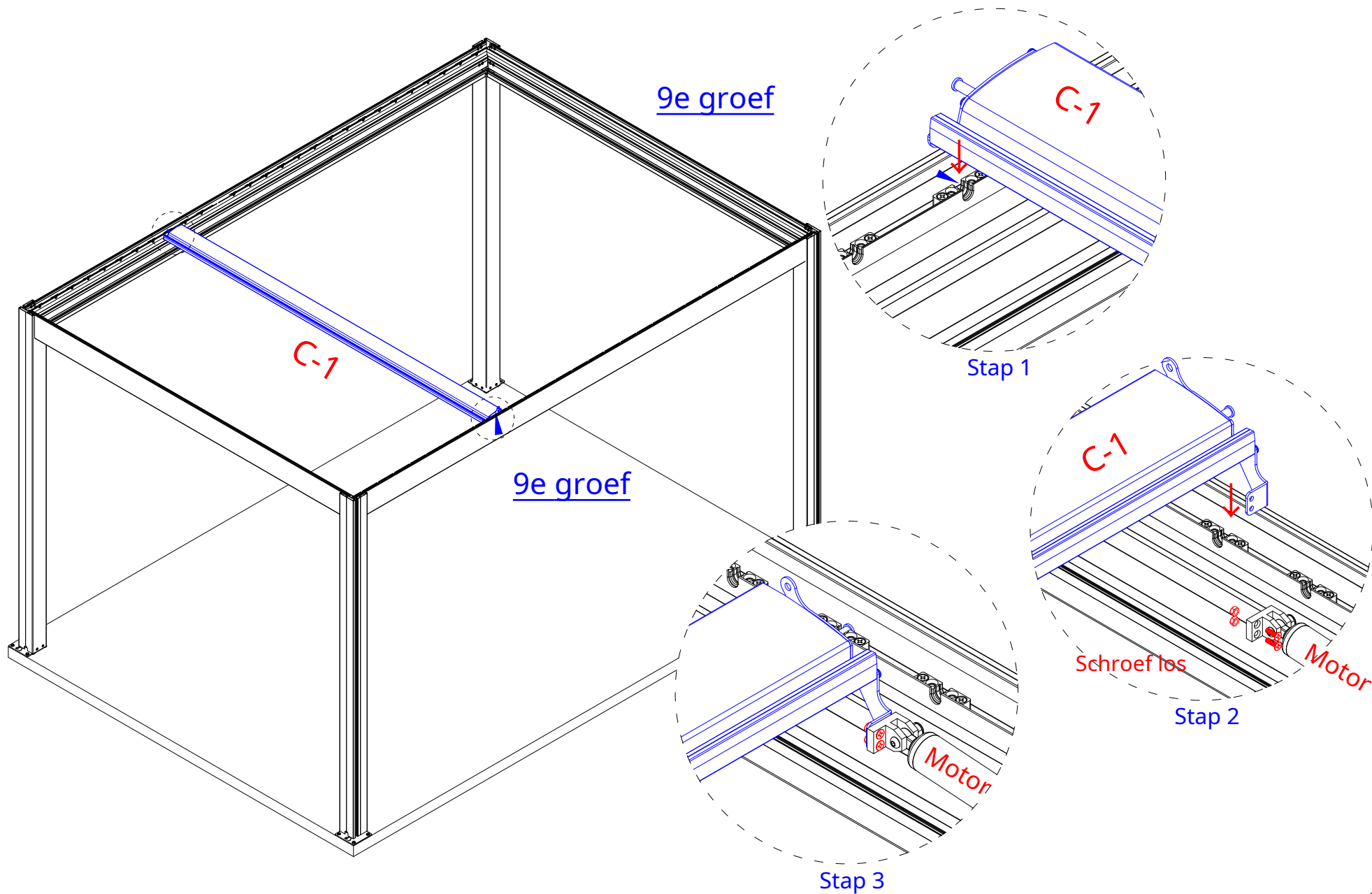

C-2 x 27



Louvre installeren

3) Zoals afgebeeld klikt het lamel C-2 rechtstreeks in de groef.

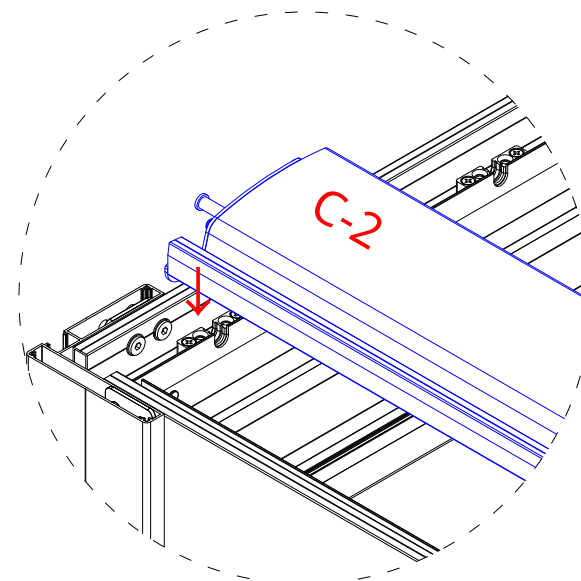
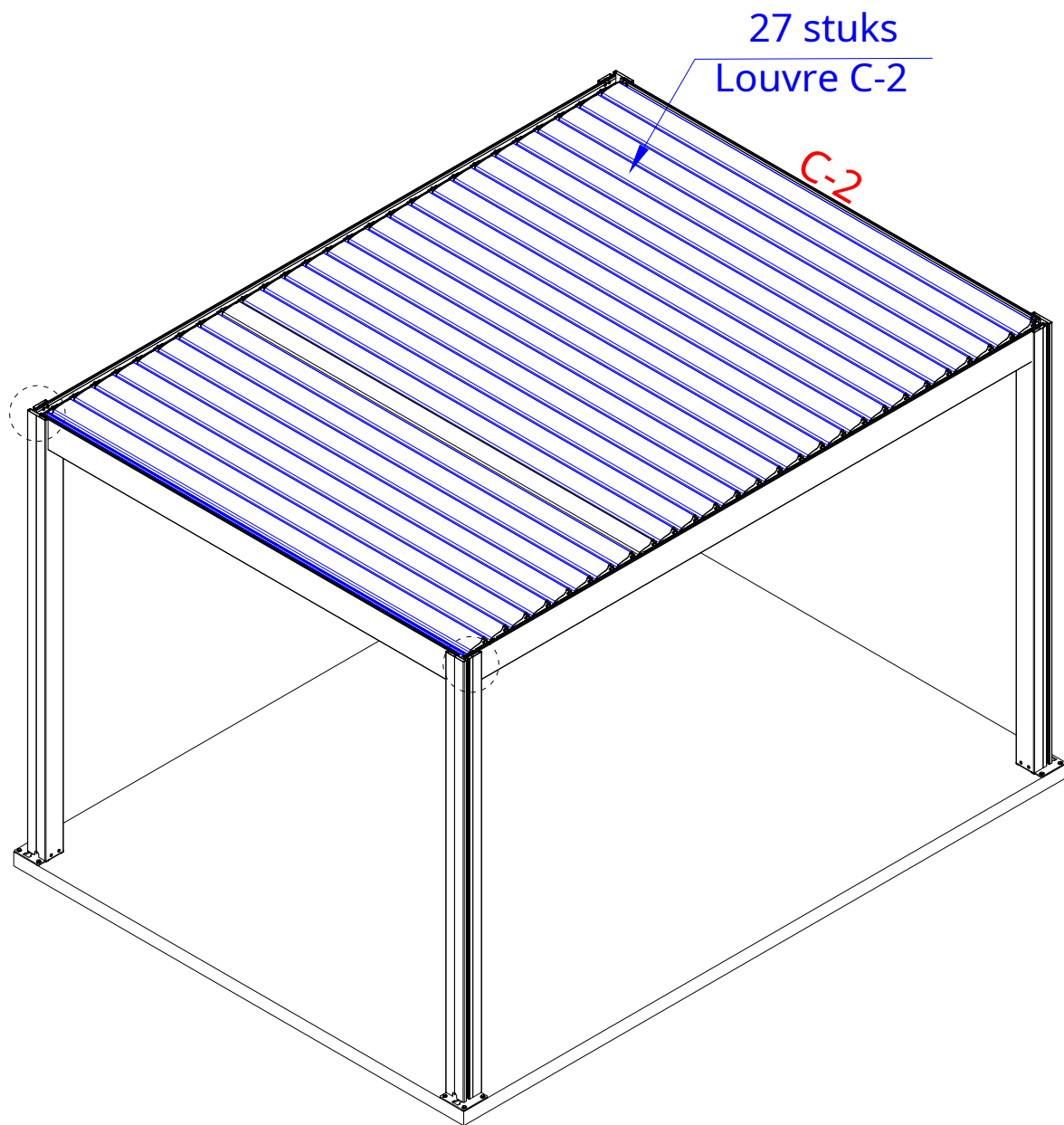

Stap 1

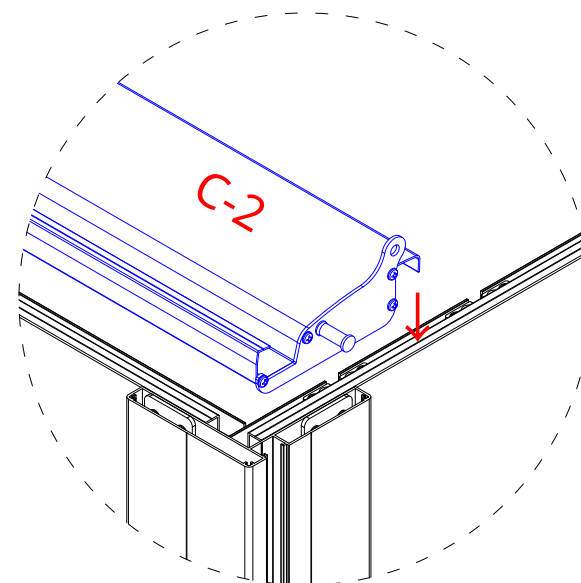

Stap 2

9

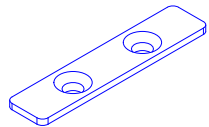

x 56

10



x 112

Louvre installeren

4) Bevestig de ashouderdop zoals afgebeeld 9 aanschacht houder met M5*16 Verzonken schroef 10.

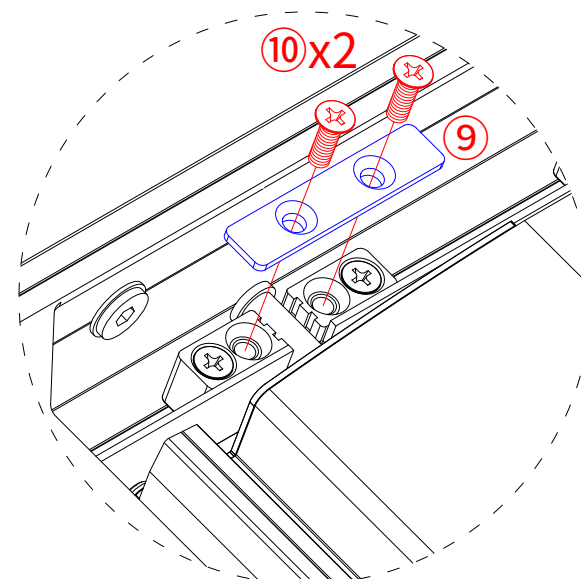
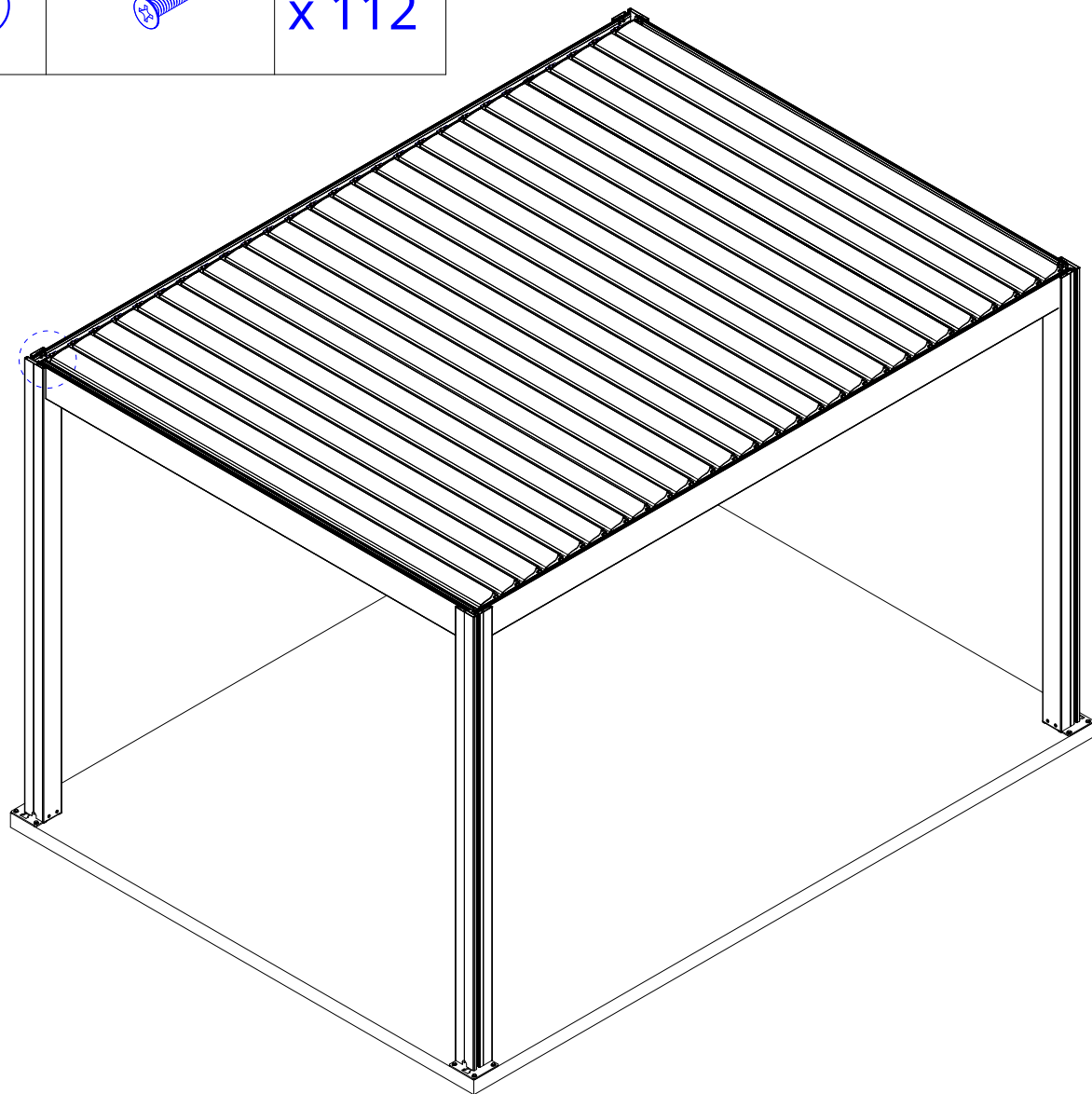

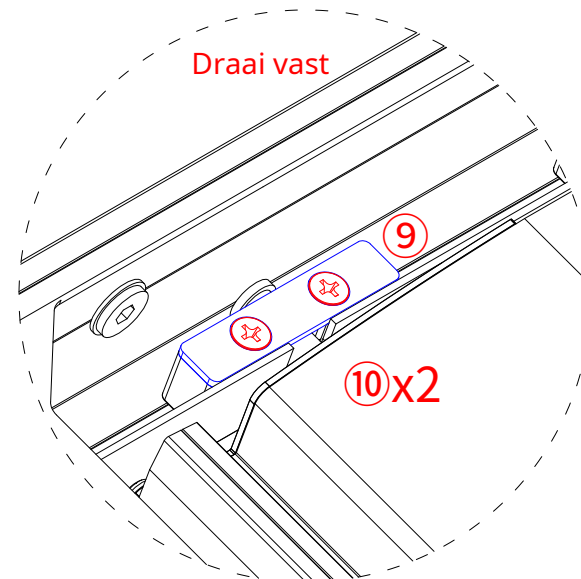

Stap 1



Stap 2

Draai vast

D		x 1
11		x 28

Louvre installeren

5) Gebruik de M6*5 zeskantduimschroef zoals afgebeeld 11 door het gat (op bedieningsstang D) en vervolgens bevestigd op de lamel.

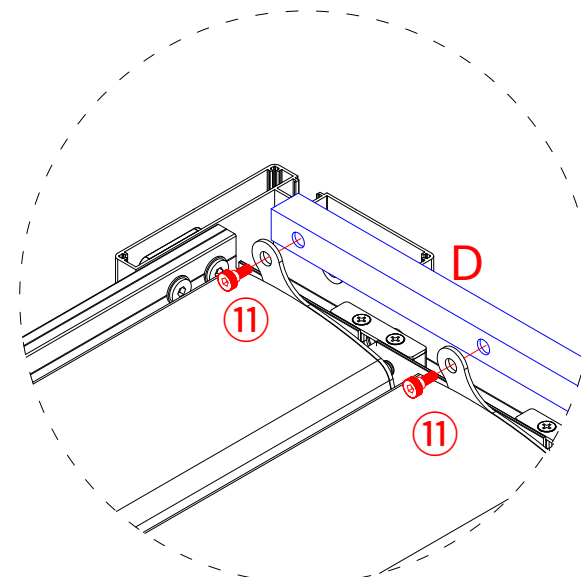
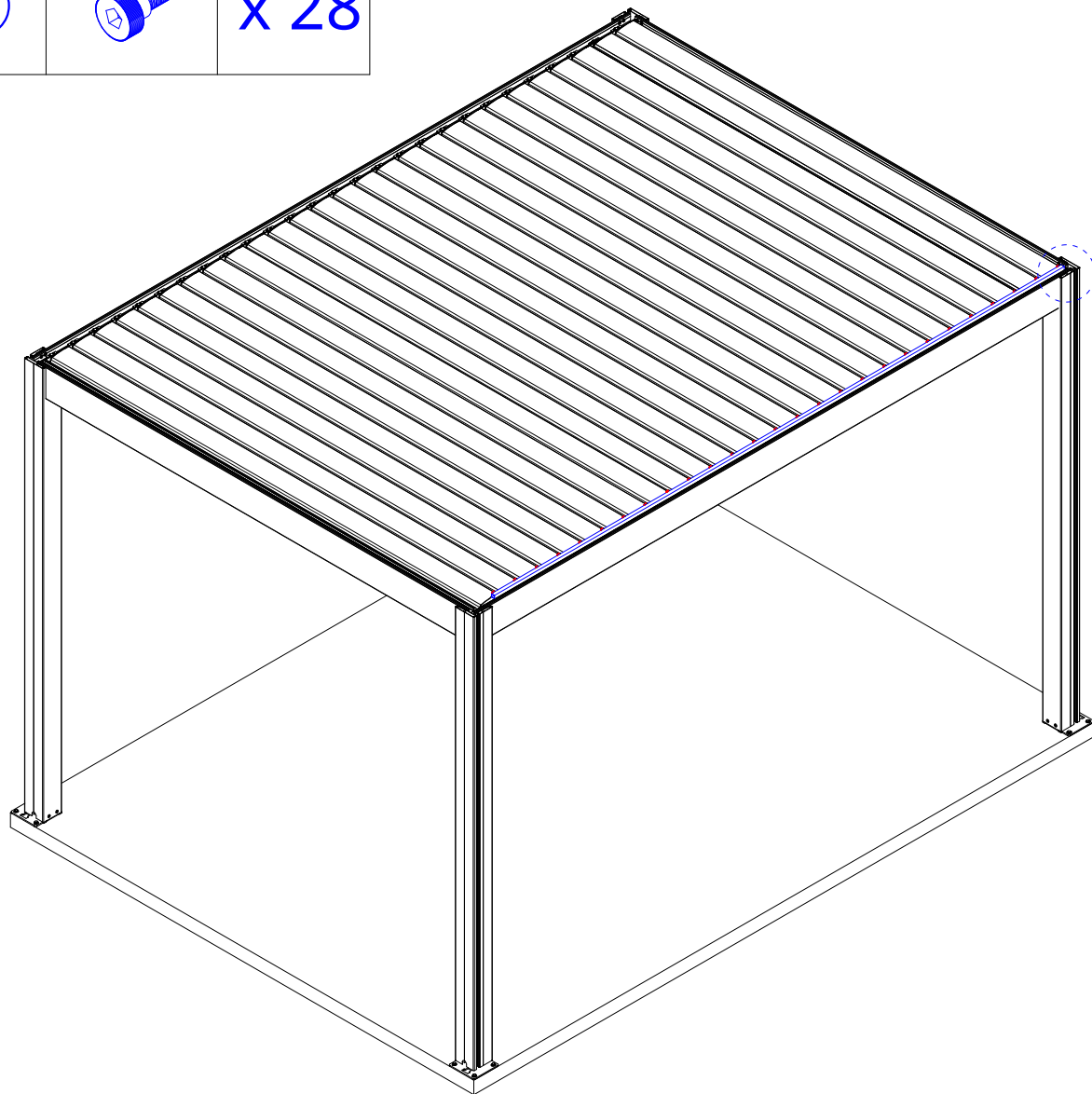

Stap 1

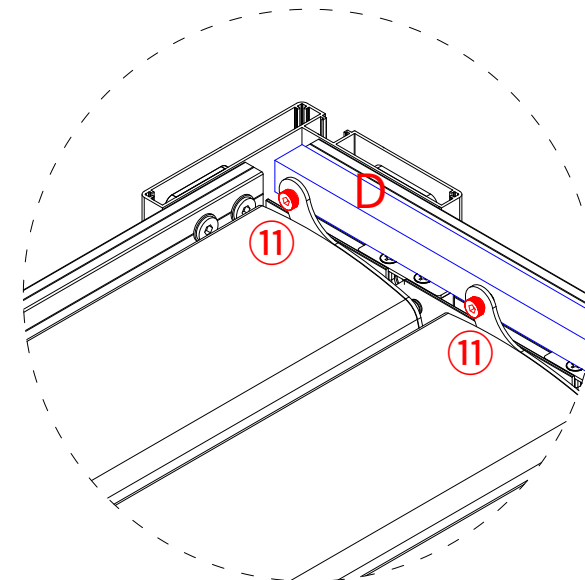

Stap 2

E



x 4

Bevestig de T-sleufafdekking

1) Steek zoals afgebeeld de T-sleufafdekking E in de groef van de paal.

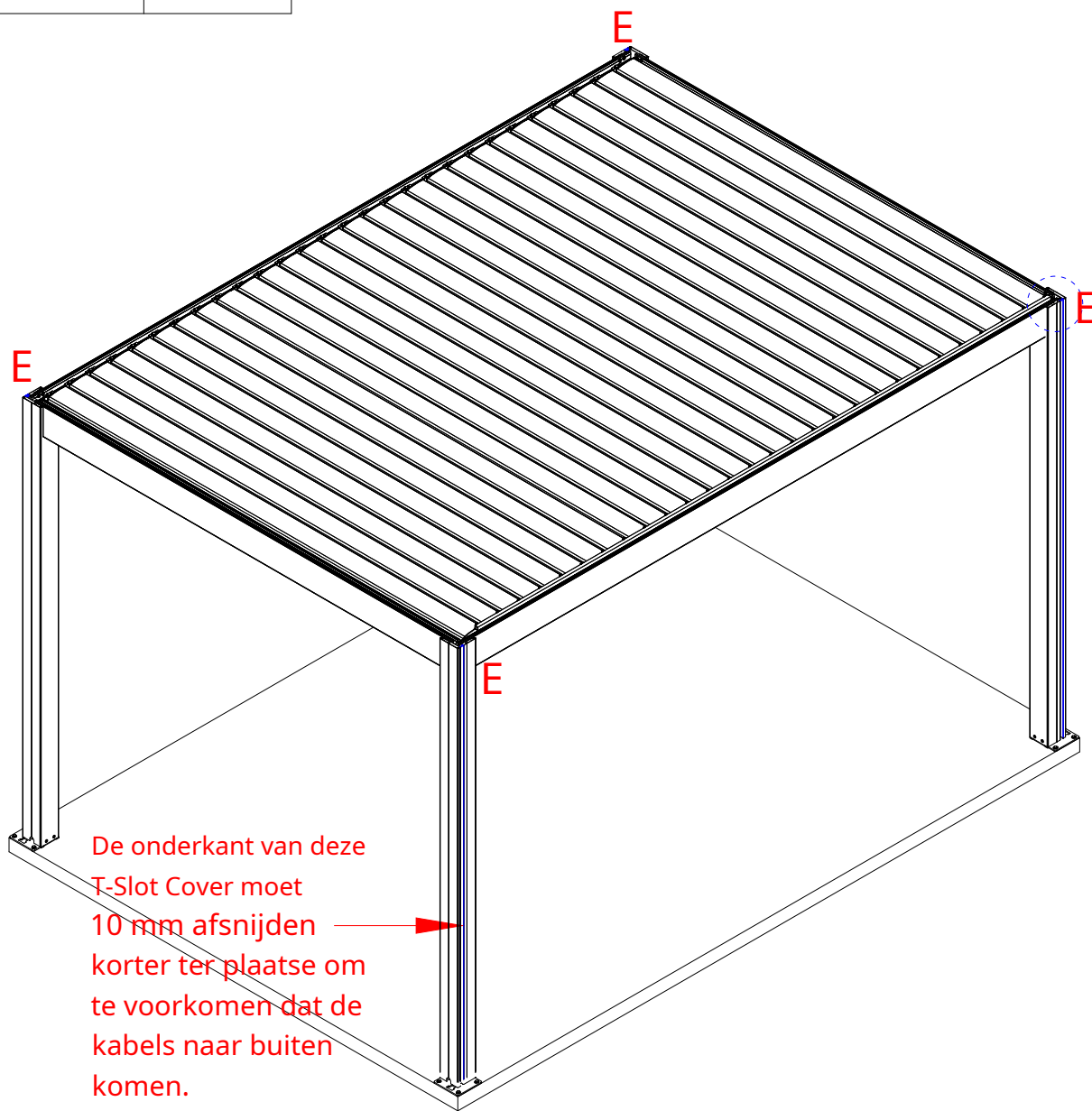

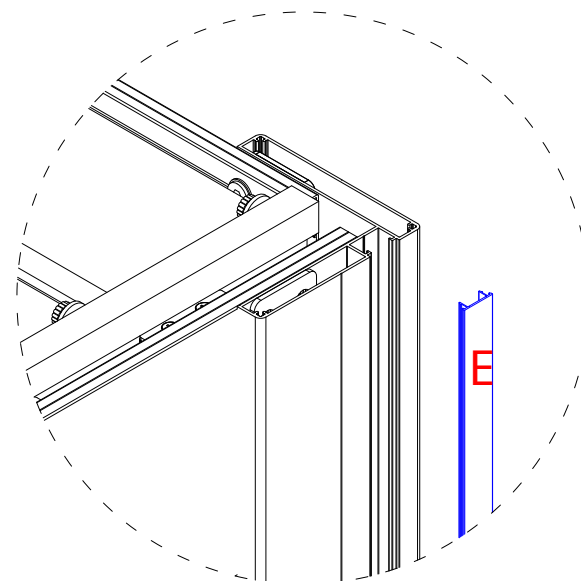

De onderkant van deze T-Slot Cover moet 10 mm afsnijden korter ter plaatse om te voorkomen dat de kabels naar buiten komen.

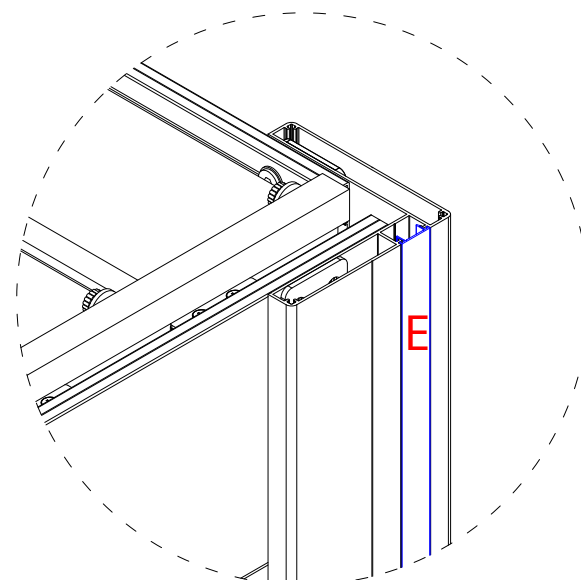

Stap 1

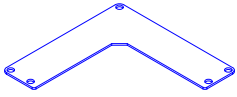

Stap 2

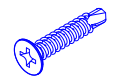
12		x 4
13		x 12
15		x 8

Bevestig de paalbovenafdekking

2) Plaats de L-vormige eindkapplaat, zoals weergegeven 12 op de bovenkant van de paal en bevestig deze vervolgens met 3 van 4,2*16 zelftappende schroeven 13 en 2 van 4,2*19 boorstaartschroeven 15.

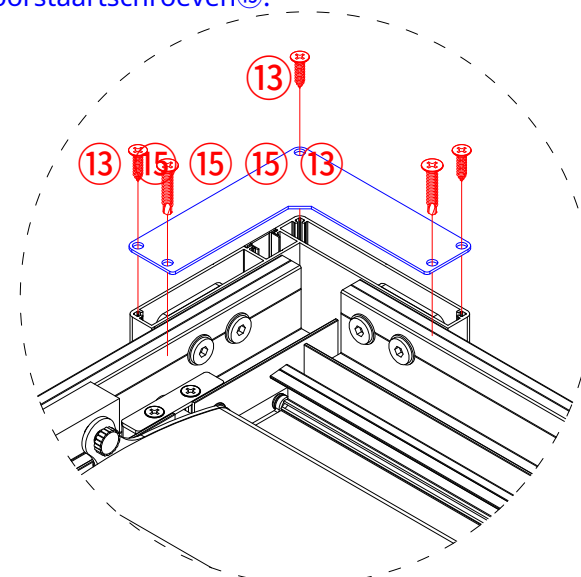
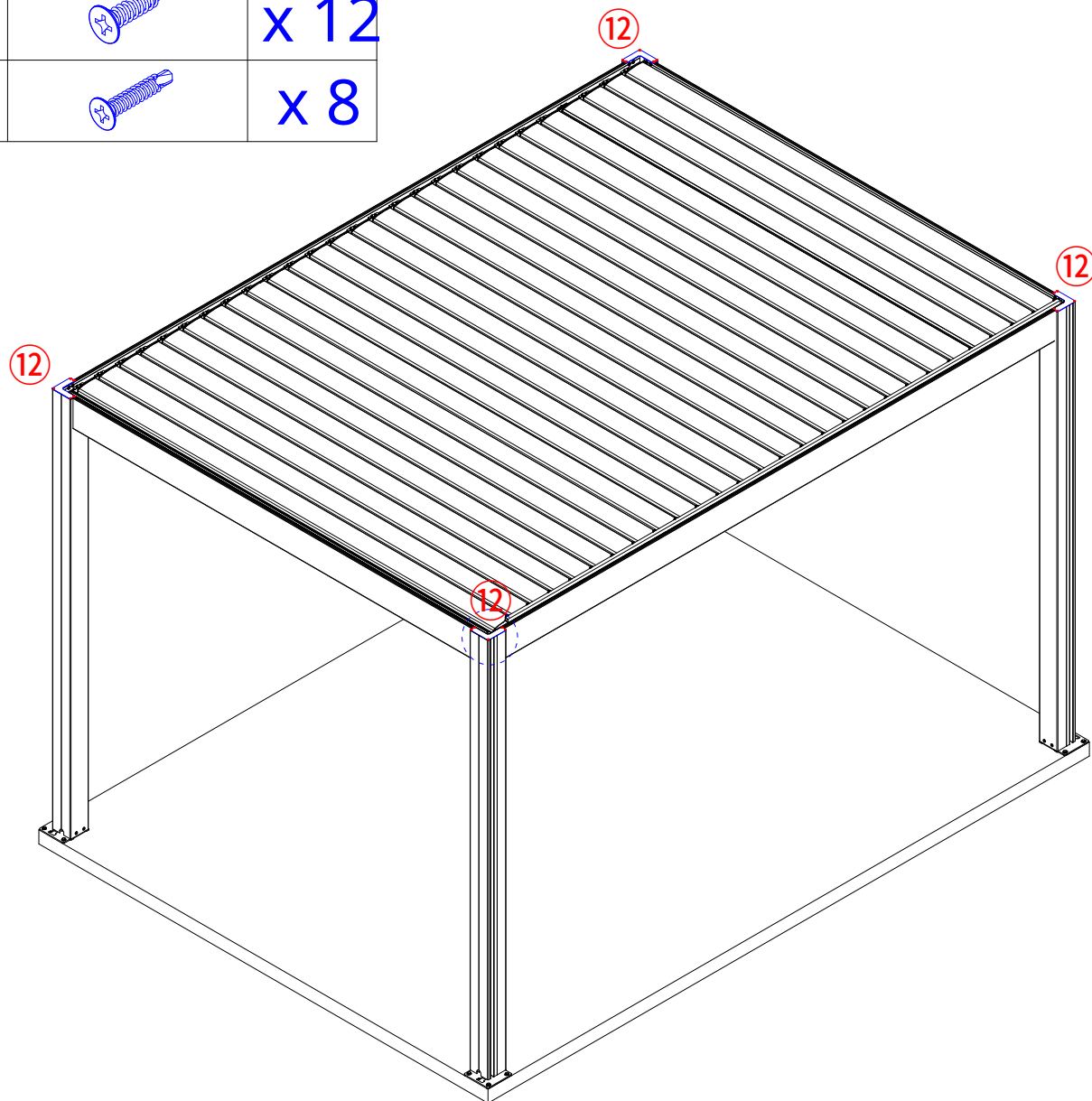

Stap 1

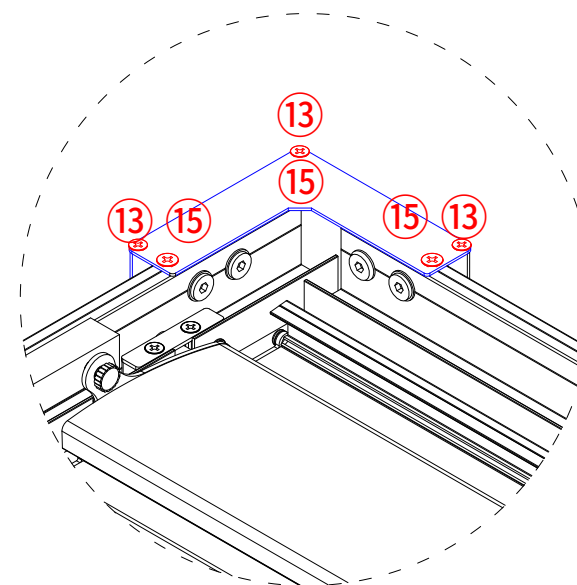

Stap 2

2

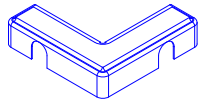

x 4

De bodemplaatafdekking installeren

1) Zoals afgebeeld moet de U-vormige inkeping van de bodemplaatafdekking in dezelfde richting wijzen als de afvoeropening. De bodemplaatafdekking op paal met extra afvoeruitsparing.

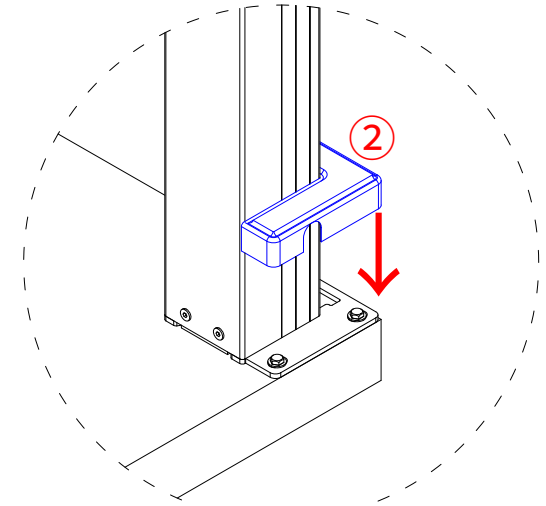
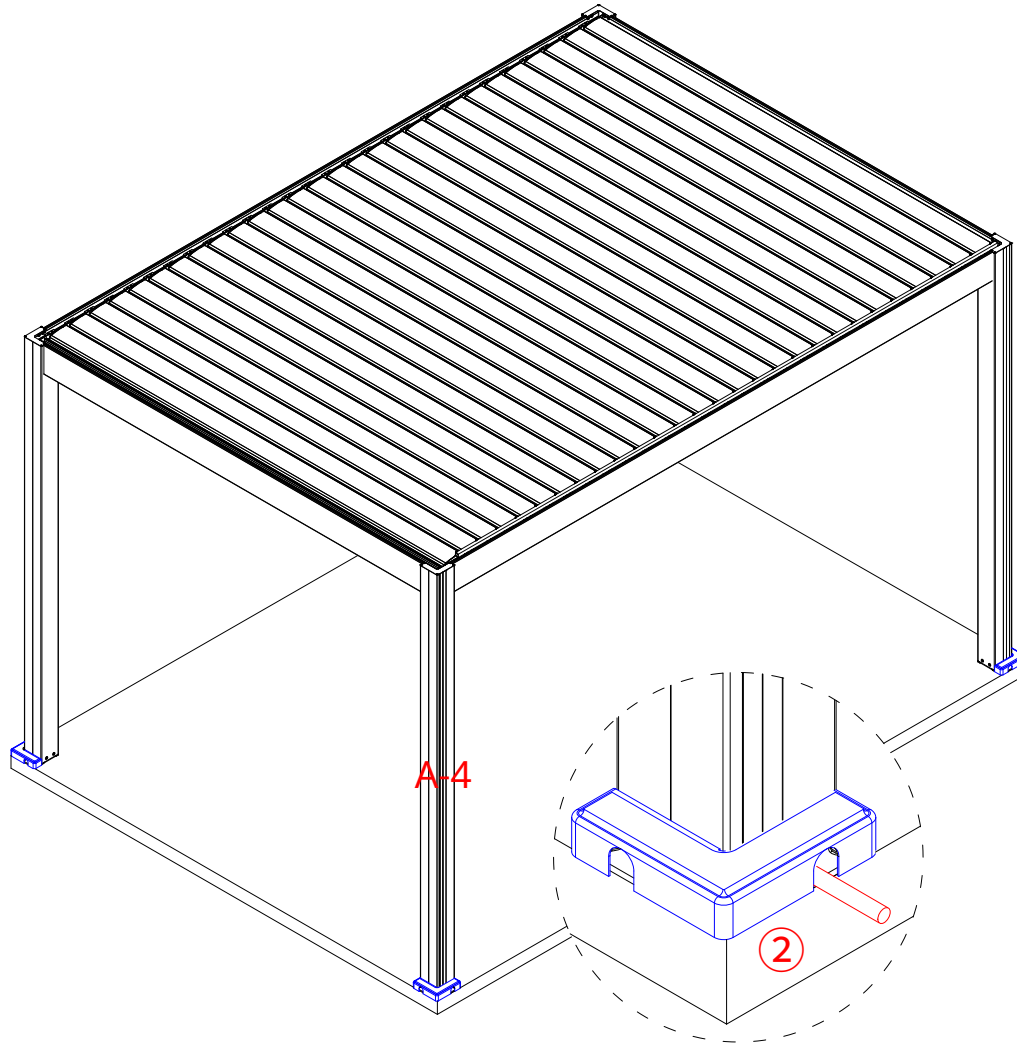

Stap 1

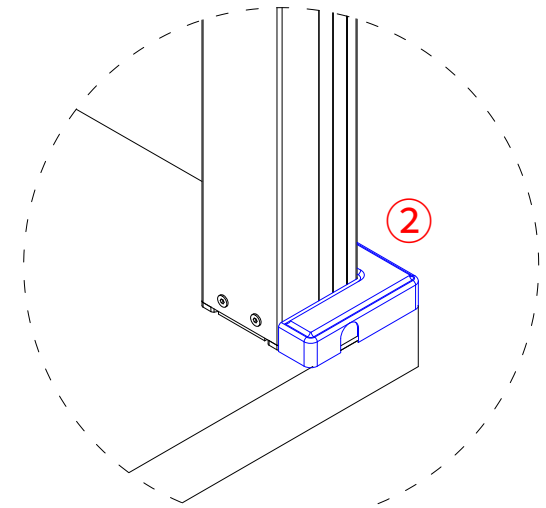

Stap 2

Wanneer de afstandsbediening en ontvanger de motor niet kunnen besturen, volgt u de onderstaande stappen om opnieuw te programmeren.

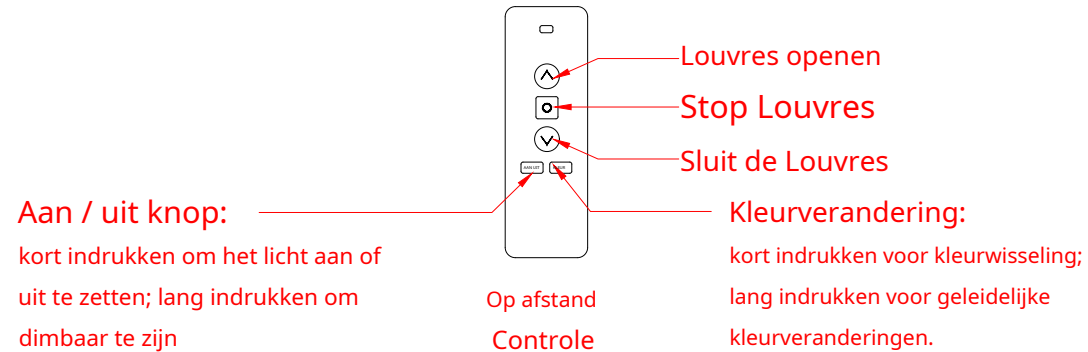

Stappen voor koppelen:

①

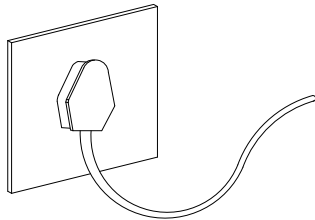

Schakel de stroom gedurende 15 seconden uit en sluit de stroom vervolgens weer aan voer binnen 30 seconden de volgende stappen uit.

②



Open de achterklep van de afstandsbediening/ontvanger, houd de knop ingedrukt **U2-knop** langer dan 7 seconden.

③

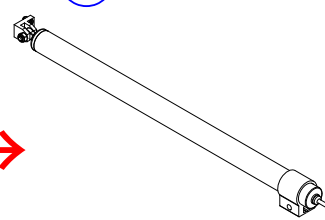

Wanneer de motor blijft maken A "pieppieppiep" geluid.

④

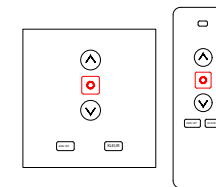

Houd de knop ingedrukt **stop knop** van de afstandsbediening/ontvanger opnieuw langer dan 2 seconden ingedrukt. Wanneer de "pieppieppiep" Het geluid van de motor verdwijnt, dit betekent dat de afstandsbediening/ontvanger succesvol is gekoppeld.

Richtingsveranderende stappen:

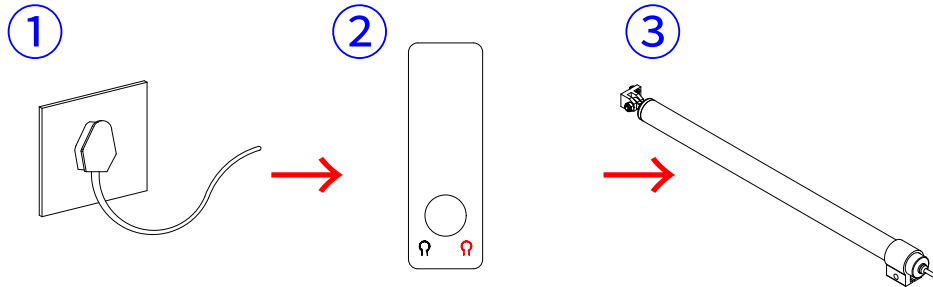

Schakel de stroom gedurende 15 seconden uit en sluit vervolgens opnieuw aan **de macht dus** begin alsjeblieft met de volgende stappen binnen 30 seconden.

Open de achterklep van de afstandsbediening/ontvanger, houd de knop ingedrukt **U2-knop** langer dan 7 seconden.

Wanneer de motor blijft maken A "pieppieppiep" geluid.

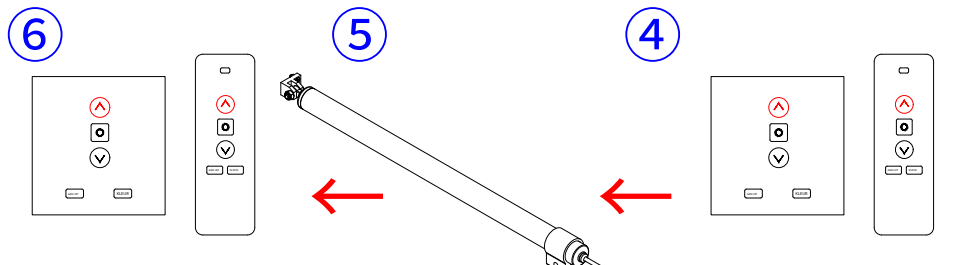

Houd de knop ingedrukt **knop omhoog** van de afstandsbediening gedurende meer dan 2 seconden.

De motor maakt A "pieppieppiep" klinkt weer

Houd de knop ingedrukt **knop omhoog** van de afstandsbediening/ontvanger voor langer dan 2 seconden.

Koppelingsverwijderingsstappen:

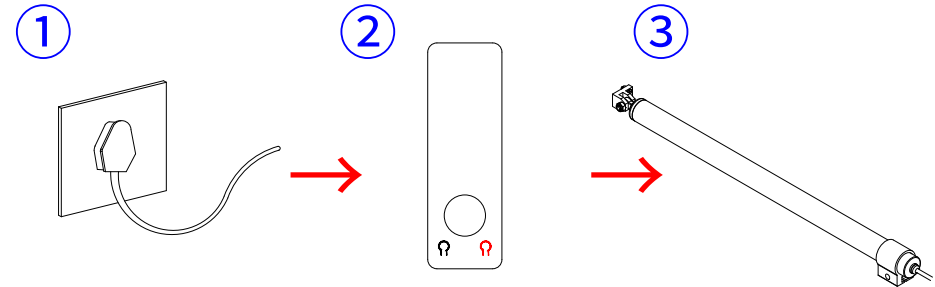

Schakel de stroom gedurende 15 seconden uit en sluit vervolgens opnieuw aan **de macht dus** begin alsjeblieft met de volgende stappen binnen 30 seconden.

Open de achterklep van de afstandsbediening/ontvanger, houd de knop ingedrukt **U2-knop** langer dan 7 seconden.

Wanneer de motor blijft maken A "pieppieppiep" geluid.

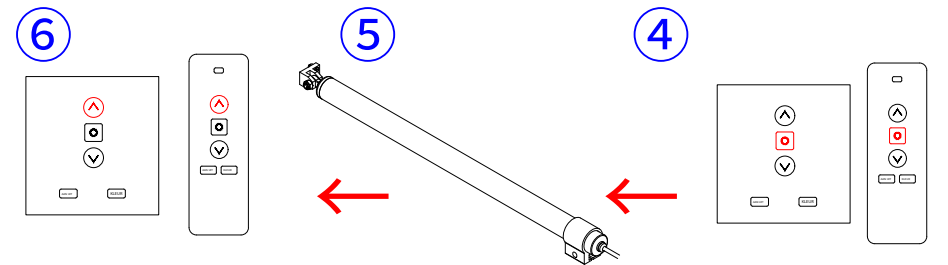

Houd de knop ingedrukt **knop omhoog** van de afstandsbediening/ontvanger voor langer dan 2 seconden. Verwijder de koppeling met succes.

De motor maakt A "pieppieppiep" klinkt weer

Houd de knop ingedrukt **stop knop** van de afstandsbediening/ontvanger voor langer dan 2 seconden.

Zorg voor uw pergola

Structuuroppervlakken bedekt met thermohardende poedercoatings moeten eenmaal per jaar worden gereinigd om hun oorspronkelijke esthetische uiterlijk te behouden.

Thermohardende poeders zijn gevoelig voor:

- Fysieke wrijving, harde schokken, extrusie, chemicaliën, waaronder alkalisch oplosmiddel en zuur oplosmiddel.
- Natuurlijke elementen zoals wind, regen, sneeuw en langdurig zonlicht. De buitenkant van de pergola kan na verloop van tijd verslechteren en dit valt niet onder de garantie.

Uw pergola schoonmaken

- Gebruik geen schuursponsje, crèmereiniger, schuurspons, ijzerdraadbal of gekleurde doeken.
- Aanbevolen: zachte spons, zachte zandvrije doek, watten, katoen of vliespapier (alleen wit).
- Gebruik geen bijtende producten zoals zure of alkalische reinigingsmiddelen. Het wordt aanbevolen om te wassen met water met een neutraal pH-reinigingsmiddel en het vervolgens af te vegen met een doek om het droog te houden.
- Bij het reinigen met hogedrukapparatuur moeten dezelfde voorzorgsmaatregelen worden genomen als bij het reinigen van de carrosserie: afstand, type mondstuk, watertemperatuur en druk moeten allemaal in aanmerking worden genomen.

Gebruik Herinnering

- Controleer nadat de installatie is voltooid of de schroeven goed vastzitten. Vergeet niet om de schroeven minstens één keer per jaar te controleren.
- **In gevallen waarin sneeuwval, hagel of harde wind van meer dan 80 km/u wordt voorspeld, wordt aanbevolen de lamellen te openen. Bedien de messen niet bij vorst of sneeuw. Verwijder de bladen van de pergola als er veel sneeuw ligt.**
- Controleer regelmatig de afdichtingsomstandigheden om er zeker van te zijn dat de afdichtingen of andere componenten niet lekken.
- Ruim regelmatig vuil op, zoals gevallen bladeren op de pergola, om verstopping van de afvoer te voorkomen.
- Gebruiksbeperkingen: Waterdichte systemen zijn, hoewel effectief, niet ontworpen om volledige waterdichtheid te garanderen. Zware regen en harde wind kunnen de pergola beschadigen. Eventuele opgelopen schade wordt niet gedekt door de garantie.

BRUKERMANUAL

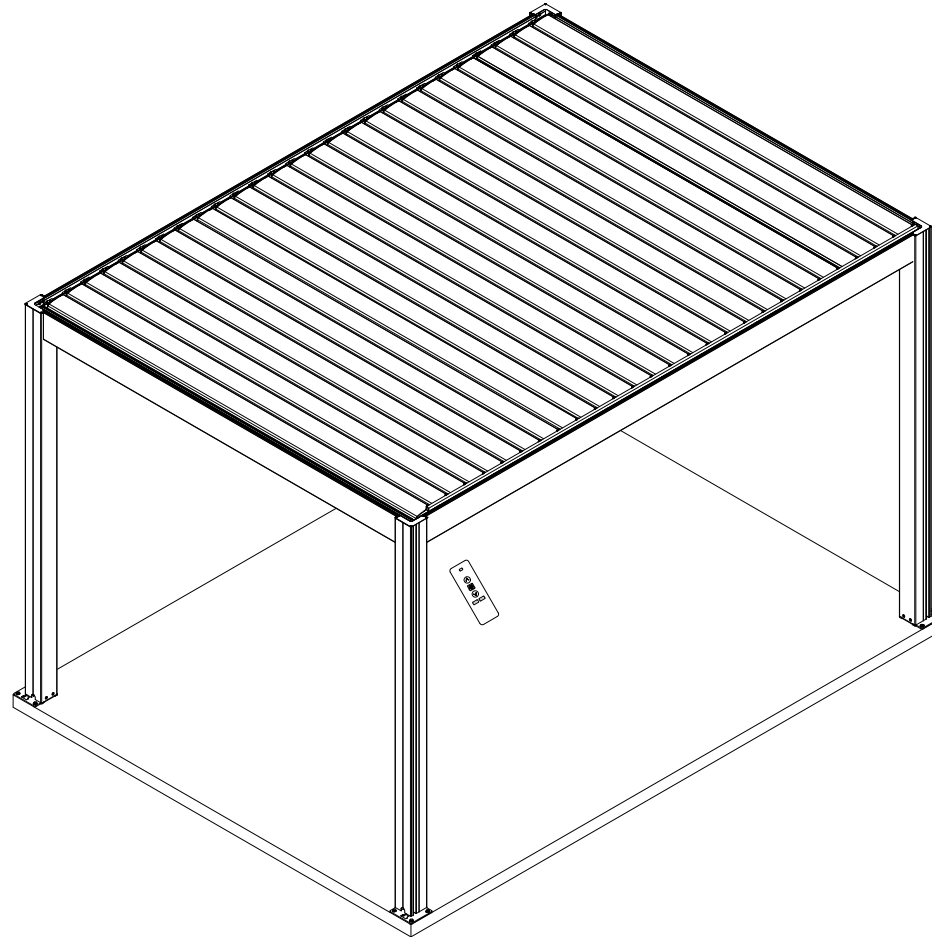

OTHER LANGUAGES

Pergola 4 x2,86m

Les denne bruksanvisningen før du bruker pergolaen din for første gang.
Ta vare på denne håndboken for fremtidig referanse.

Pergola

Åpning: Elektrisk

Størrelse: 295,3 (Lengde) x 409 (Bredde) -cm

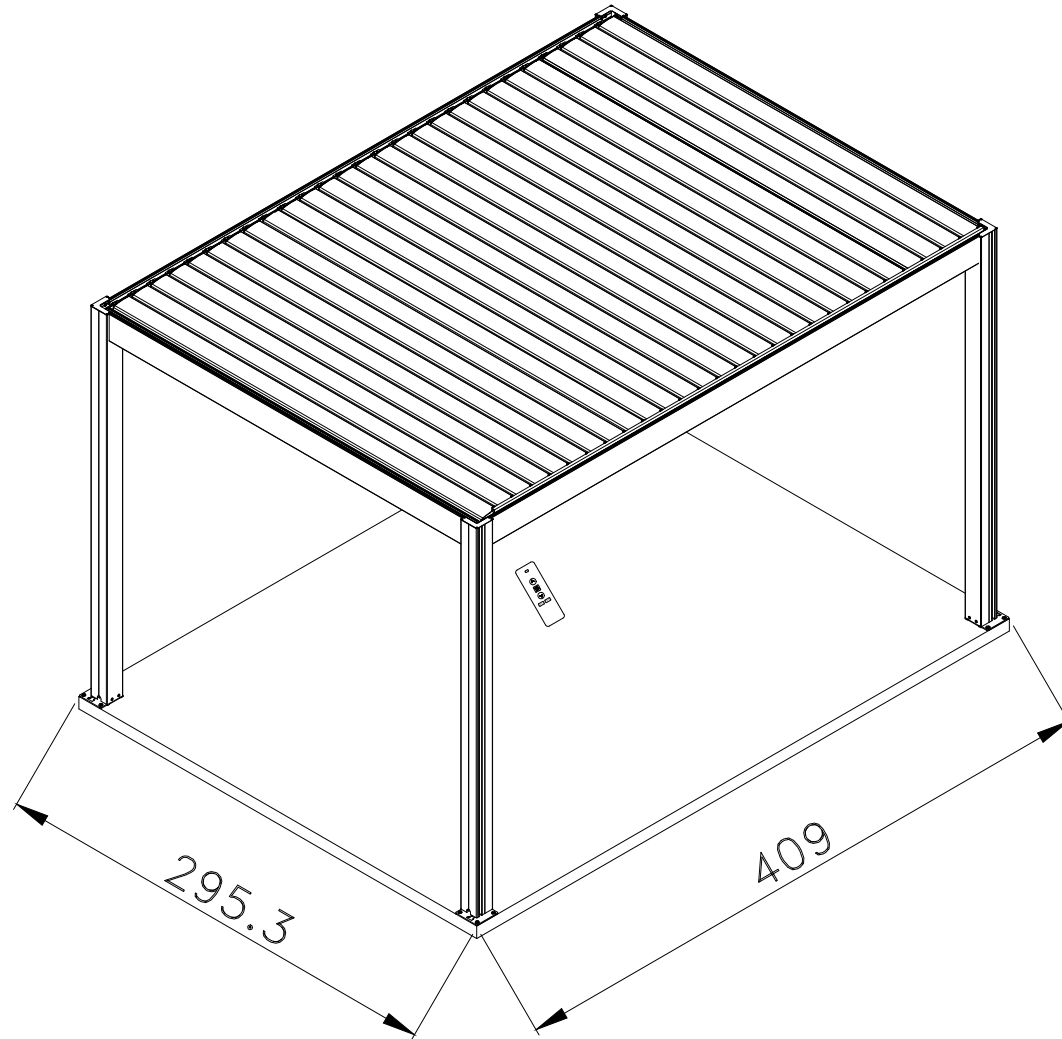

Installasjonsmerknader:

1. Installasjon krever minimum tre personer: en for måling og merking, en for montering og en som assistent.
2. Kun betonggulvfester leveres. I tilfelle det ikke er betongplate på bakken, anbefales det å lage betongplater ved hver søyle. Betongplaten bør være minimum 500x500x500mm.
3. Etter at Pergola-rammen er montert, bruk en firkant, vater og linjal for å måle produktets nivå og diagonal for å sikre størrelsen på pergolaen. Basene må være nøyaktig jevne uten toleranse.
4. Pergolaen må boltes til gulvet. Vi tar ingen ansvar dersom fliser er sprukket under boring av boltene.
5. Elektroverktøy er nødvendig: sørg for at de fungerer som de skal og følg sikkerhetsinstruksjonene.
6. Vær forsiktig når du bruker skarpe verktøy.
7. Bruk verneklær inkludert vernebriller, hjelmer og hansker.
8. Ikke klatre eller stå på taket.

Sikkerhetsadvarsel

- . Det anbefales sterkt å bruke hansker ved montering.
- . Ikke installer pergola under dårlige værforhold, som vind eller regn.
- . Ikke berør noen ledninger med aluminiumsprofiler.
- . Bruk alltid vernesko og briller når du installerer pergola.
- . Oppbevar alle plastposer utilgjengelig for barn.
- . Pergolasøylen må plasseres og festes på en flat overflate.
- . Ikke len deg på søylen under monteringsfasen.
- . Ikke la barn nærme seg åstedet under monteringsfasen.
- . Ikke vær i nærheten av pergola i storm eller tyfon.
- . Ikke prøv å klatre pergola under påvirkning av alkohol eller narkotika.
- . Når du bruker stiger eller lignende verktøy og elektroverktøy under monteringsfasen, sørg for å følge produsentens sikkerhetsanbefalinger.
- . Ethvert varmt verktøy, for eksempel en elektrisk drill, kan ikke være i kontakt med pergolaprofilen.
- . Pass på at det ikke er noen kabler eller andre kabler skjult under jorden før du plasserer søylen.

Generelle råd

- . Denne pergolaen har flere komponenter og den tar minst 90 minutter å montere. Pergolaen bør ikke plasseres under et tre.
- . Hvis du kobler søylen direkte til sement eller en lignende base, bruk forhåndsstansede hull på den medfølgende basen.
- . Sjekk antall profiler og beslag før montering og bruk dem i henhold til listen over profilbeslag for enkel montering.
- . Legg små biter som skruer i en beholder for å unngå tap.
- . Vær oppmerksom på posisjonen til transmisjonen på bjelken for å unngå feilplassering.
- . Rengjør regelmessig løv, snø eller andre gjenstander fra pergolaen.

Vedlikehold og reparasjon

- . For å rengjøre pergola, bruk et mildt rengjøringsmiddel og skyll med vann. Ikke bruk aceton eller skurende rengjøringsmidler for å rengjøre overflaten på aluminiumsprofilen.

Garanti

- . Den generelle garantien for misfarging er 5 år, for motoren og LED-belysningen 2 år.

Beskyttelse og installasjonsverktøy

Verneutstyr:

1. Hjelm
2. Hansker
3. Førstehjelpsskrin
4. Vernebriller



Måleinstrument:

1. Målebånd (5 meter eller mer)
2. Firkantet linjal
3. Nivå

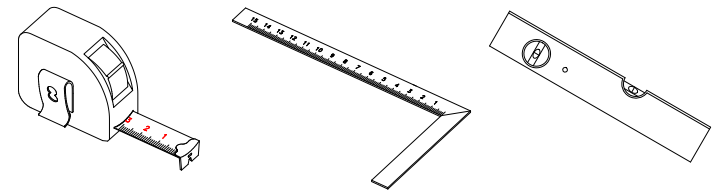



Verktøy:

1. 2 meter stige (1,5 meter eller mer)
2. 13 mm sekskantnøkkel
3. 17 mm sekskantnøkkel
4. Elektrisk drill
5. Elektrisk bor (10 mm bor)
6. Tusch eller blyant
7. Gummihammer
8. Tetningsmasse og limpistol





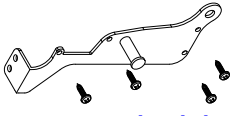
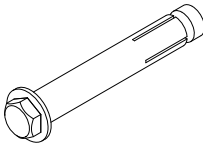
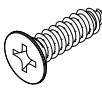
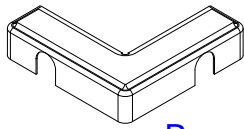
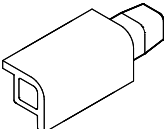
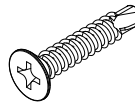
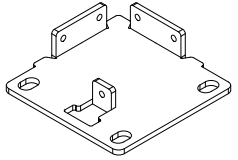
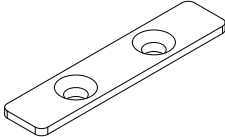
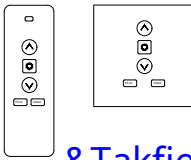
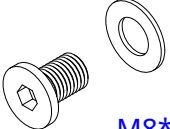

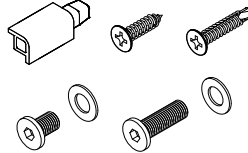
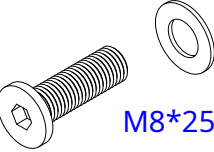
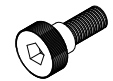
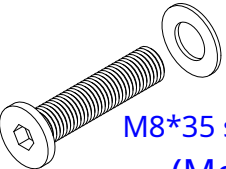
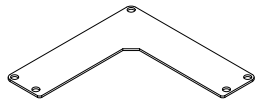

Silicon

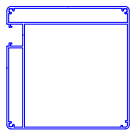
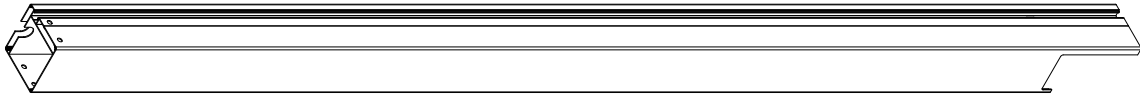
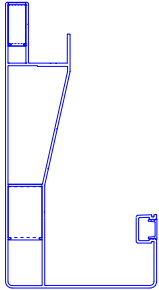
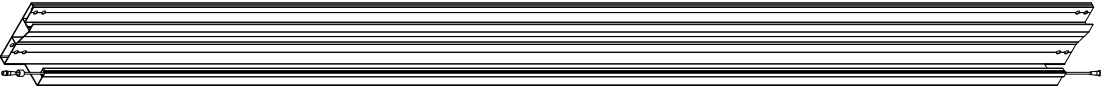
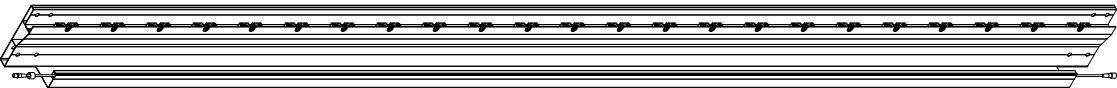
Liste over tilbehør og skruer

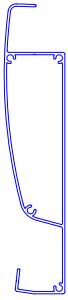
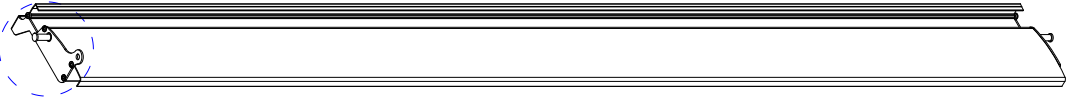
<p>①</p>	 <p>x 1 Endeløkk for Motorkoblingsventil og 4*20 flate skruer</p>	<p>⑦</p>	 <p>x 16 M8*80 Ekspansjonsskrue</p>	<p>⑬</p>	 <p>x 12 4,2*16 flathodeskrue</p>
<p>②</p>	 <p>x 4 Bunnplatedeksel</p>	<p>⑧</p>	 <p>x 4 Stolpehjørne Forlengelsesstykke</p>	<p>⑭</p>	 <p>x 8 4,2*19 Boreskrue</p>
<p>③</p>	 <p>x 4 Grunnplate</p>	<p>⑨</p>	 <p>x 56 Akselholderhette</p>	<p>⑮</p>	 <p>x 1 Mottaker & Takfjernkontroll</p>
<p>④</p>	 <p>x 16 M8*12 sekskantskruer (Med skive)</p>	<p>⑩</p>	 <p>x 112 M5*16 Forsenket skrue</p>	<p>⑯</p>	 <p>x 1 Reservedeler</p>
<p>⑤</p>	 <p>x 16 M8*25 sekskantskruer (Med skive)</p>	<p>⑪</p>	 <p>x 28 M6*5 sekskant-tommelskrue</p>	<p>⑰</p>	
<p>⑥</p>	 <p>x 16 M8*35 sekskantskruer (Med skive)</p>	<p>⑫</p>	 <p>x 4 L Stolpe Toppdeksel</p>	<p>⑱</p>	

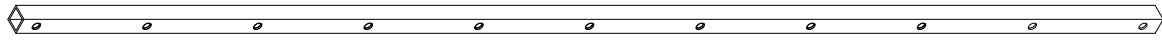
Profilliste

<p>A-1 ~ A-4</p>			<p>x 4 Post</p>
<p>B-2 B-4</p>			<p>x 2 Bjelke og takrenne</p>
<p>B-1</p>			<p>x 1 Bjelke og takrenne (med skaftholder)</p>
<p>B-3</p>			<p>x 1 Bjelke og takrenne (med akselholder) + Motor</p>
<p>C-1</p>			<p>x 1 Motorkoblingsventil</p>
<p>C-2</p>			<p>x 27 Louvre</p>
<p>D</p>			<p>x 1 Kontrollstang</p>
<p>E</p>			<p>x 4 T-spordeksel</p>

Aluminiumsprofiler Lay Out Tegning

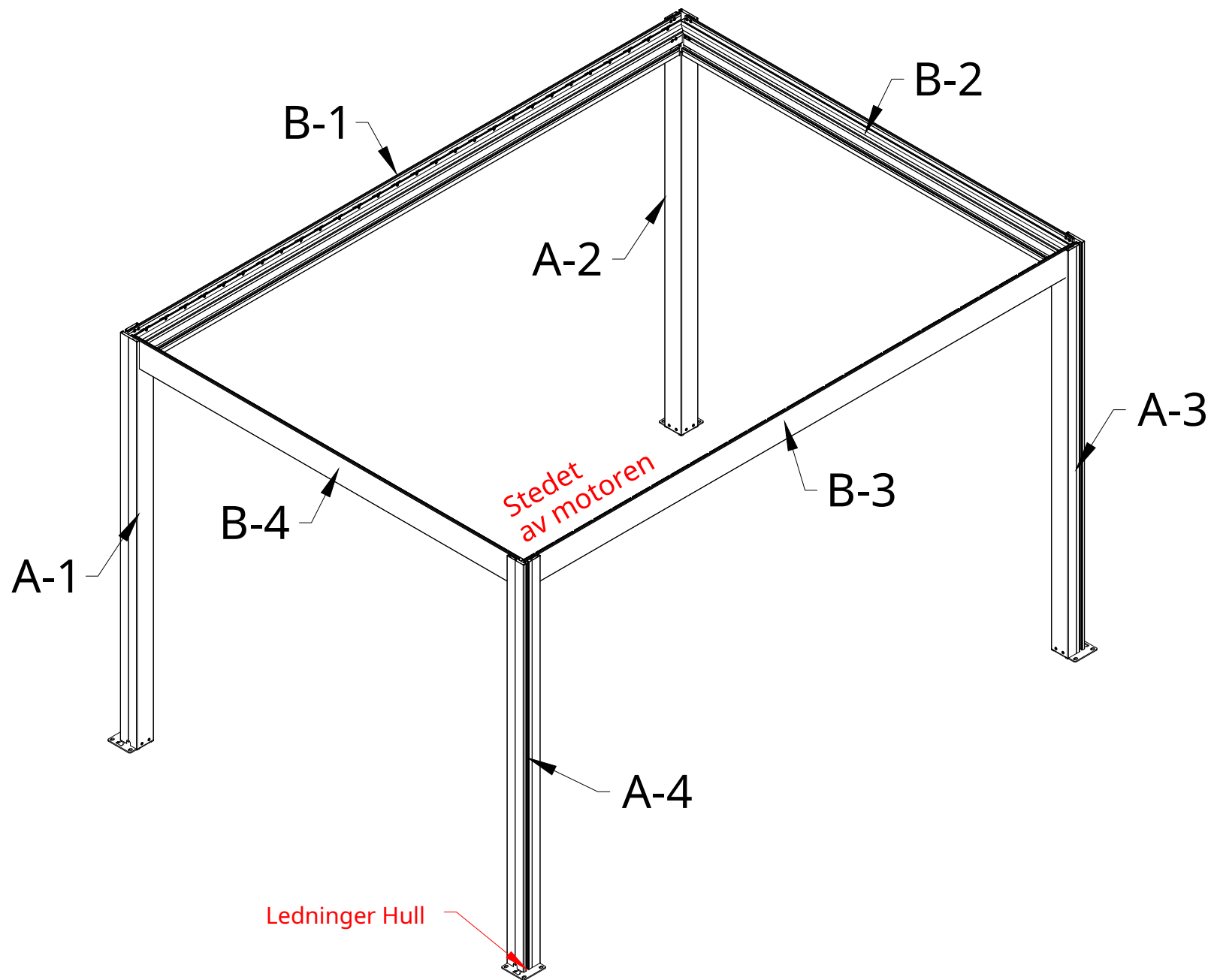

1

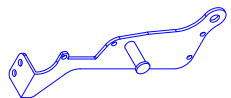

x 1



x 4

Installere motorkoblingsventil

1) Festet bladdekslet på Motor Connecting Louvre C-1 med 4*20 flathodeskruer.

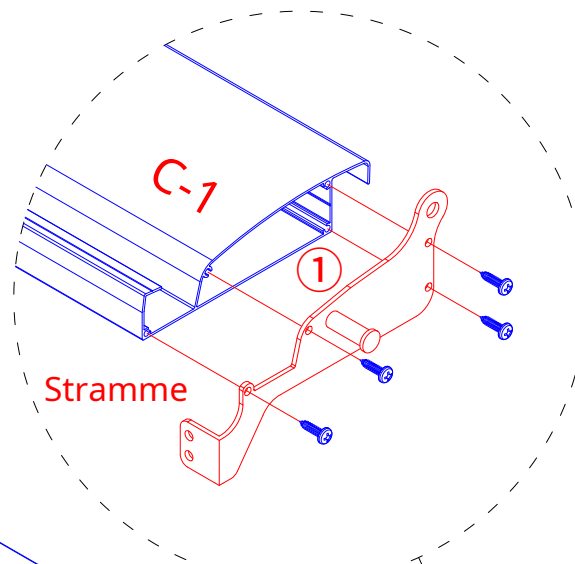

Trinn 1

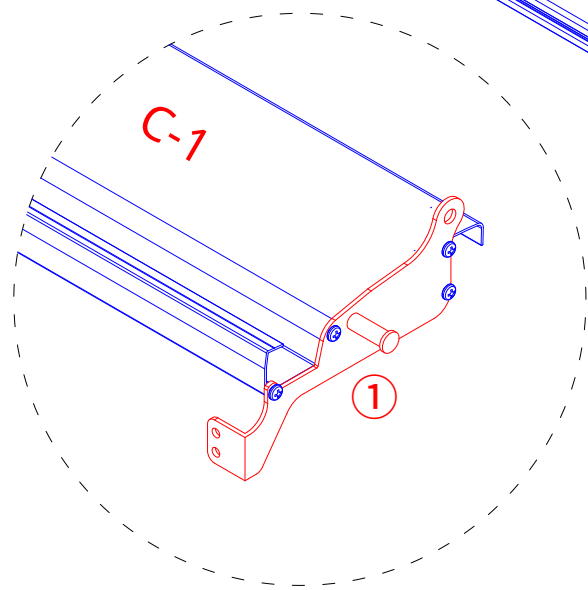

Steg 2

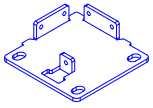
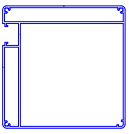
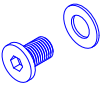

Hvis installasjonsstedet er trangt, kan bladdekslene monteres etter at rammeverket er installert.

③		x 4	A-1 ~ A-4		x 4
④		x 16			

Sett sammen rammeverket

1) Sett inn bunnplatedekslet som vist ② inn i innleggene, Juster deretter hullene i bunnplaten ③ med hullene i stolpene og lås bunnplaten ③ til stolpene med M8*12 sekskantskruer (med skive) ④.

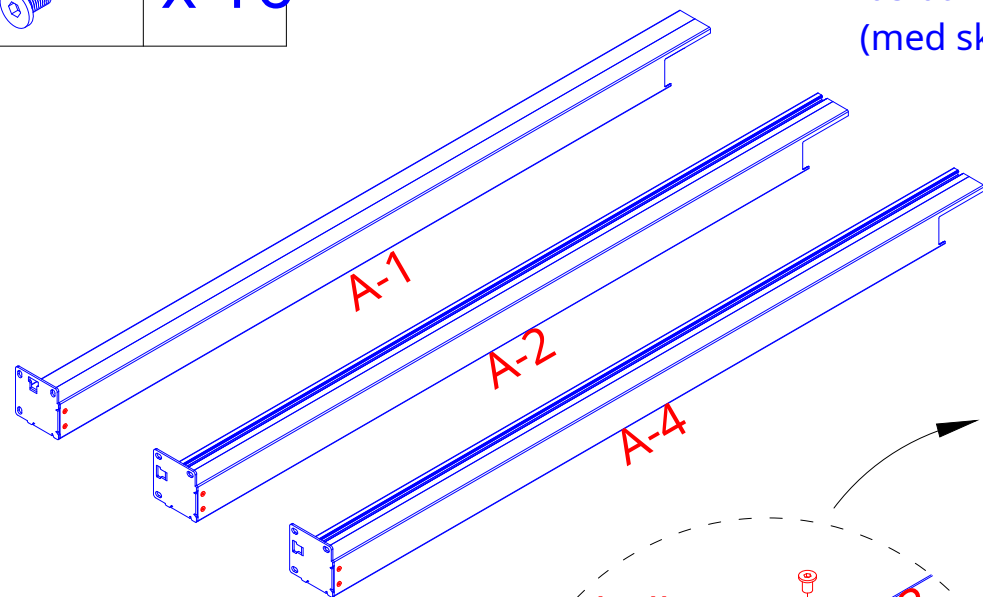

Dreneringshull

Sett inn

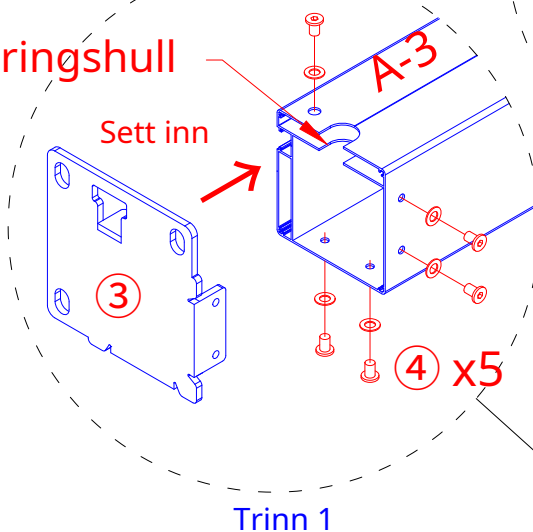

Trinn 1

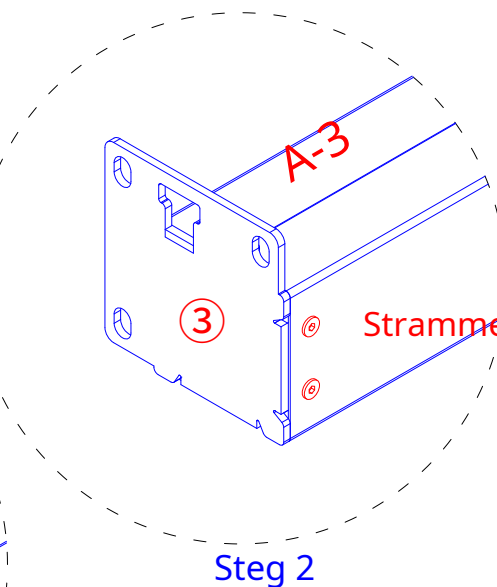

Steg 2

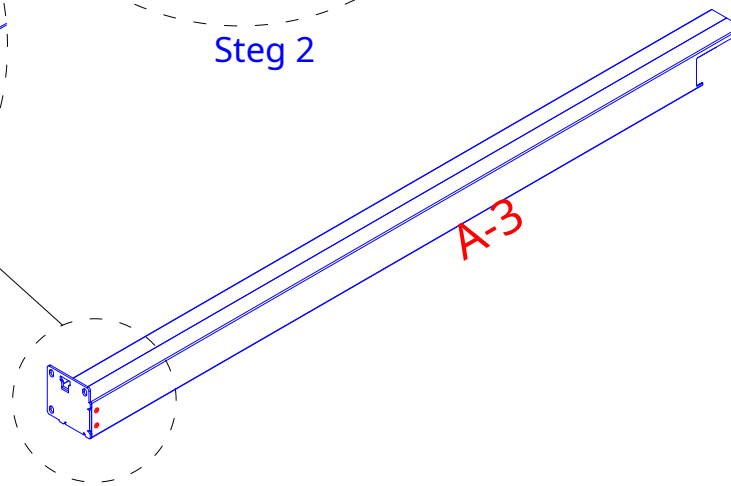

Merk:

Når du installerer alle
stolper, Drenering
Alle hull vender opp.

B-1 B-3		x 2
⑤		x 8
⑥		x 8

Sett sammen rammeverket

2) Som vist, sett inn bjelken og takrennen (B-1, B-3) inn i innleggene, så fikset bjelken og rennen (B-1, B-3) på stolpene med M8*25 sekskantskruer ⑤ og M8*35 sekskantskruer ⑥.

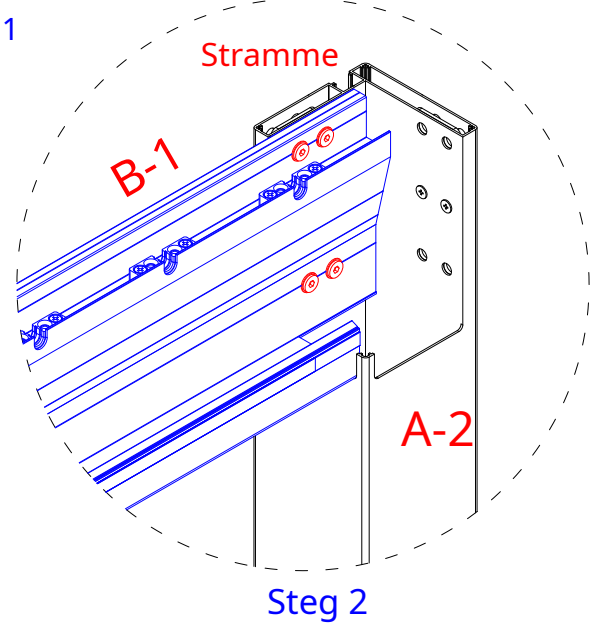
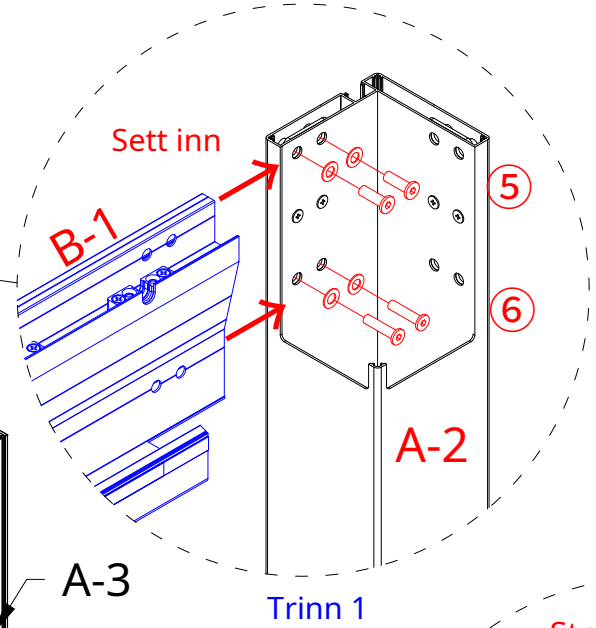
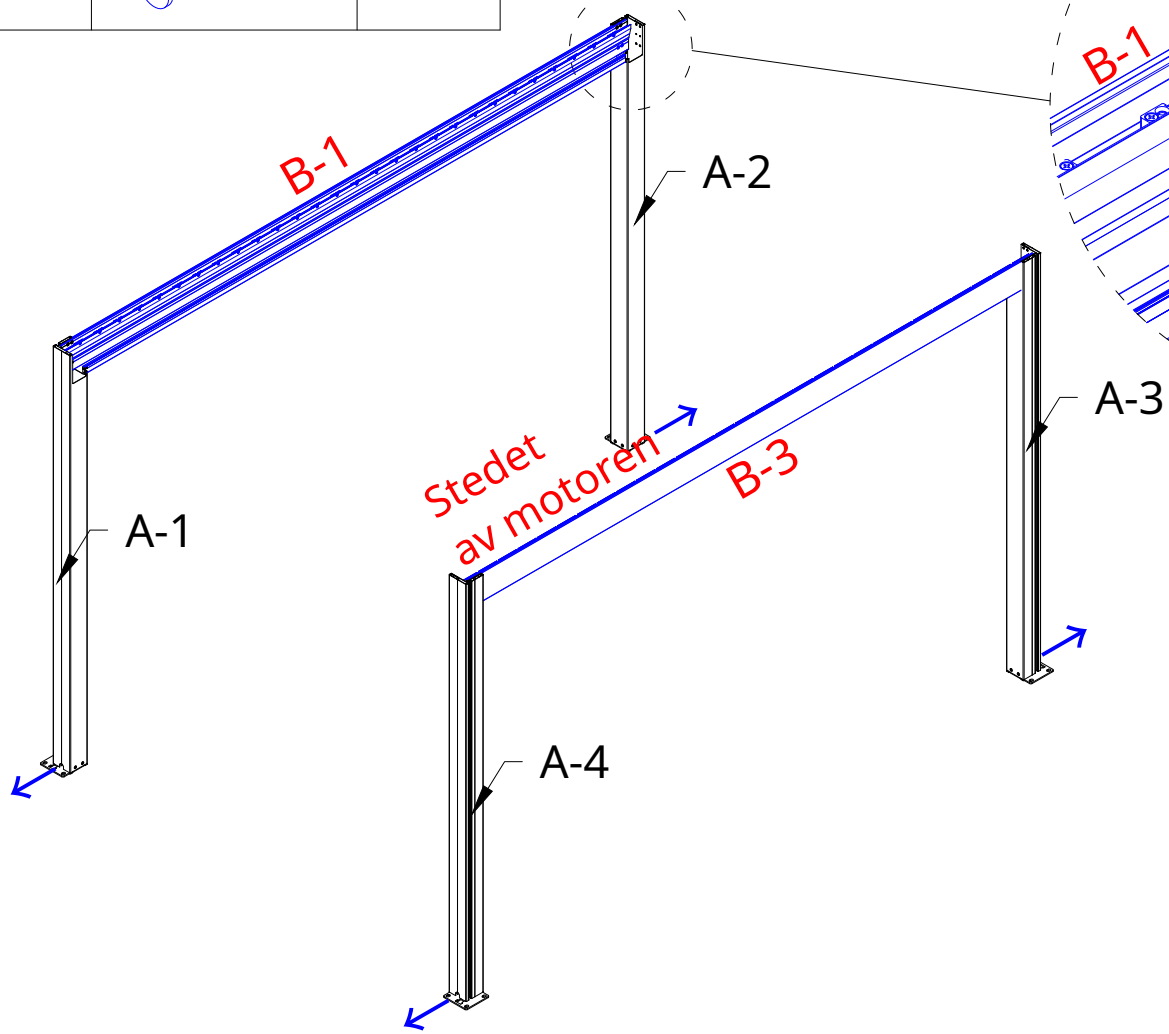

B-2 B-4		x 2
⑤		x 8
⑥		x 8

Sett sammen rammeverket
 3) Som vist, sett inn bjelke og takrenne B-2, B-4 inn i innleggene, så fikset bjelke & takrenne B-2, B-4 på stolpene med M8*25 sekskantskruer ⑤ og M8*35 sekskantskruer ⑥.

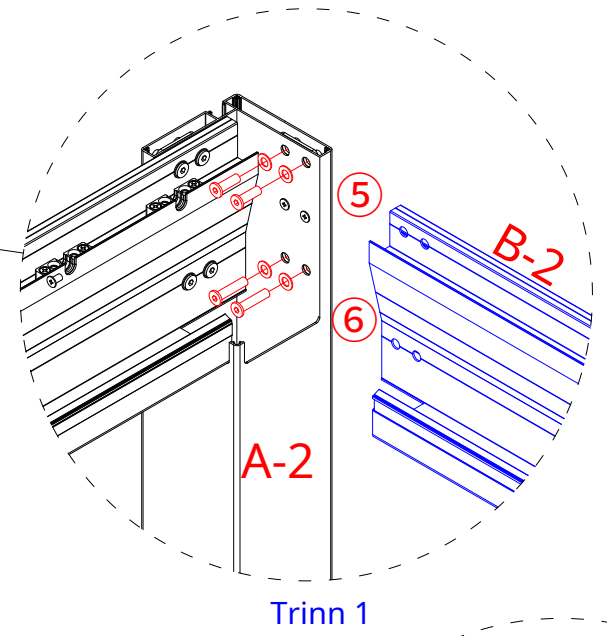
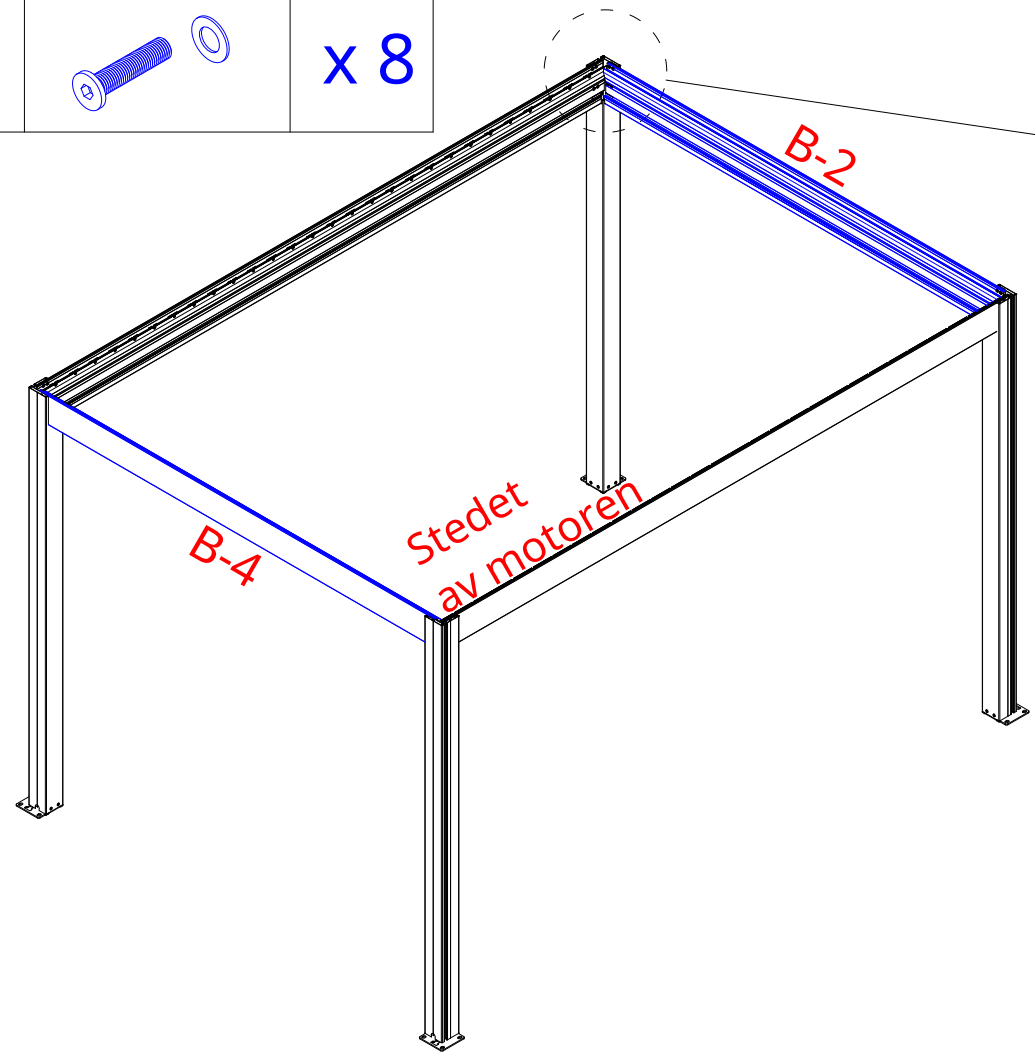

Trinn 1

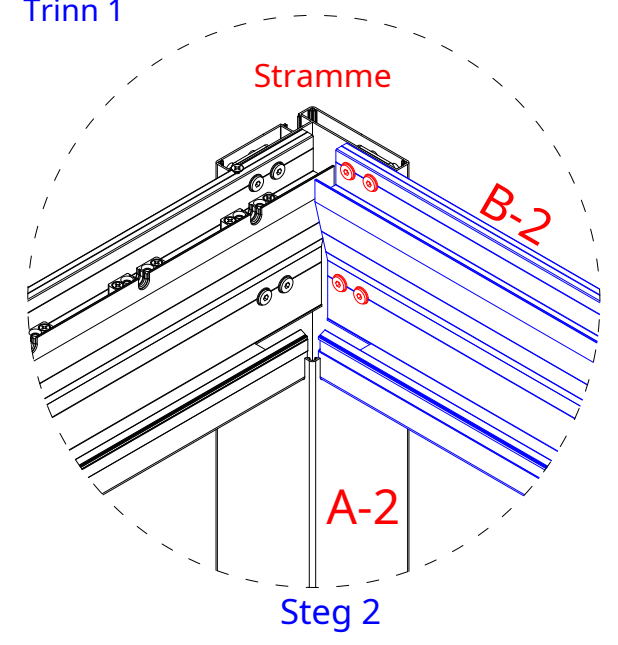

Steg 2

7

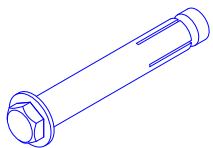

x 12

Merk:

Før du fester bunnplaten, er det nødvendig å sørge for at diagonalene til de 4 stolpene er like lange. Pass på at størrelsen $W1=W2, W3=W4$.

Fest Pergola til bakken

- 1) Bruk 12 M8*80 ekspansjonskrue ⑦ forutsatt, hvis bakken er betonggulv. Hvis ikke må du finne en annen løsning for å feste pergolaen din på ønsket overflate.
- 2) Flytt pergolaen til riktig installasjonsposisjon, merk deretter plasseringen av de fire stolpene med blyanten, fjern pergolaen og bruk den elektriske drillen til å lage 12 hull i henhold til merket. Flytt pergolaen tilbake til posisjonen og fest bunnplaten med M8*80 ekspansjonskrue ⑦.

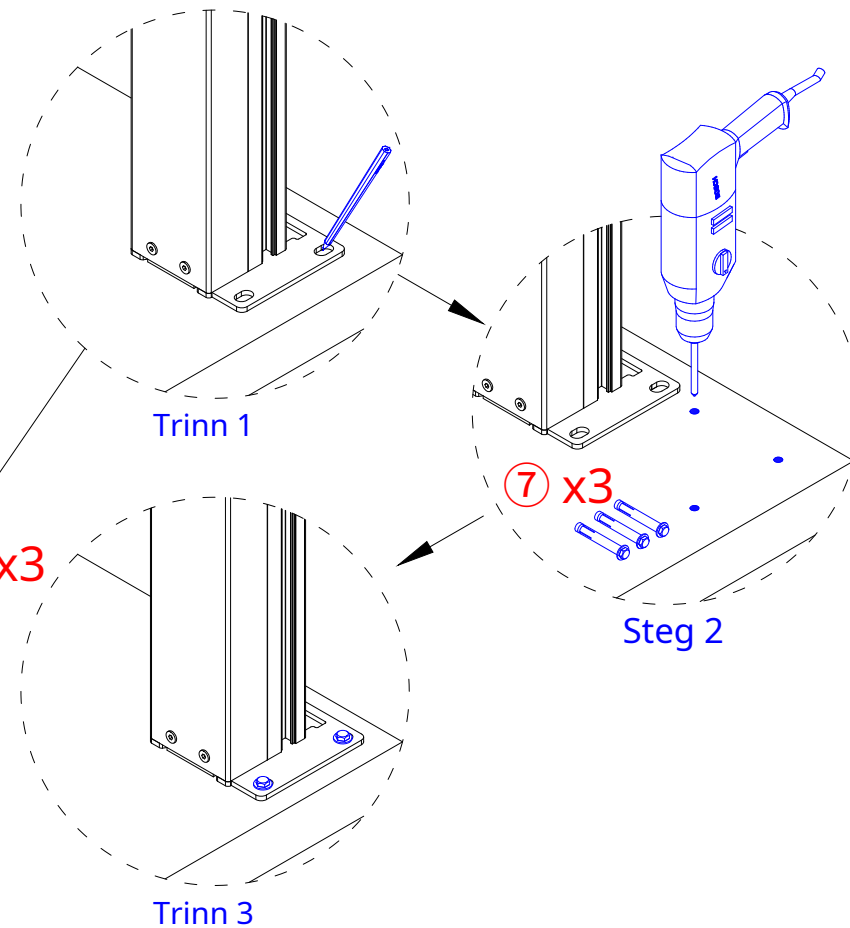
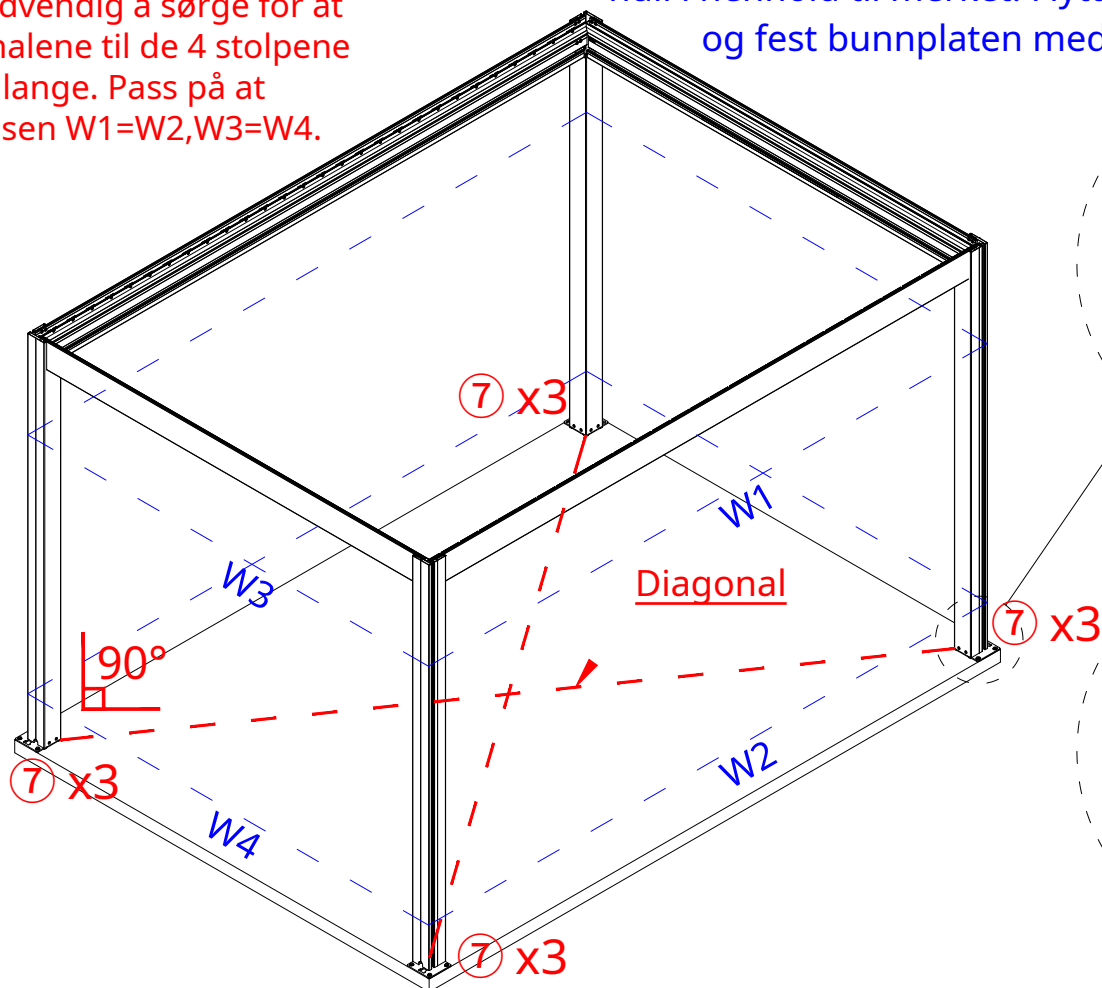

Det er brukerens ansvar å sørge for at pergolaen er festet ned. Produsenten er ikke ansvarlig for skader forårsaket av naturkatastrofer eller spesielle hendelser på pergolaen (eller dens tilbehør). Enhver pergola som ikke er fikset kan sprenge og forårsake skade, og dette ansvaret vil ikke tilskrives produsenten. Sjekk pergolaen regelmessig for å sikre at den forblir stabil og godt festet til bakken. En pergola som løsner fra sin posisjon og pådrar seg eller forårsaker skade vil ikke dekkes av garantien.

 LED ledning

 Strømledning

Kjøre ledningene

Når du legger ut ledningene, skyv dem inn i stolpen fra hakket i den øvre enden av stolpen, trekk deretter ledningene til utløpshullet, trekk deretter ledningene ut fra uttaket, og kom til slutt ut fra hullet nederst av innlegget.

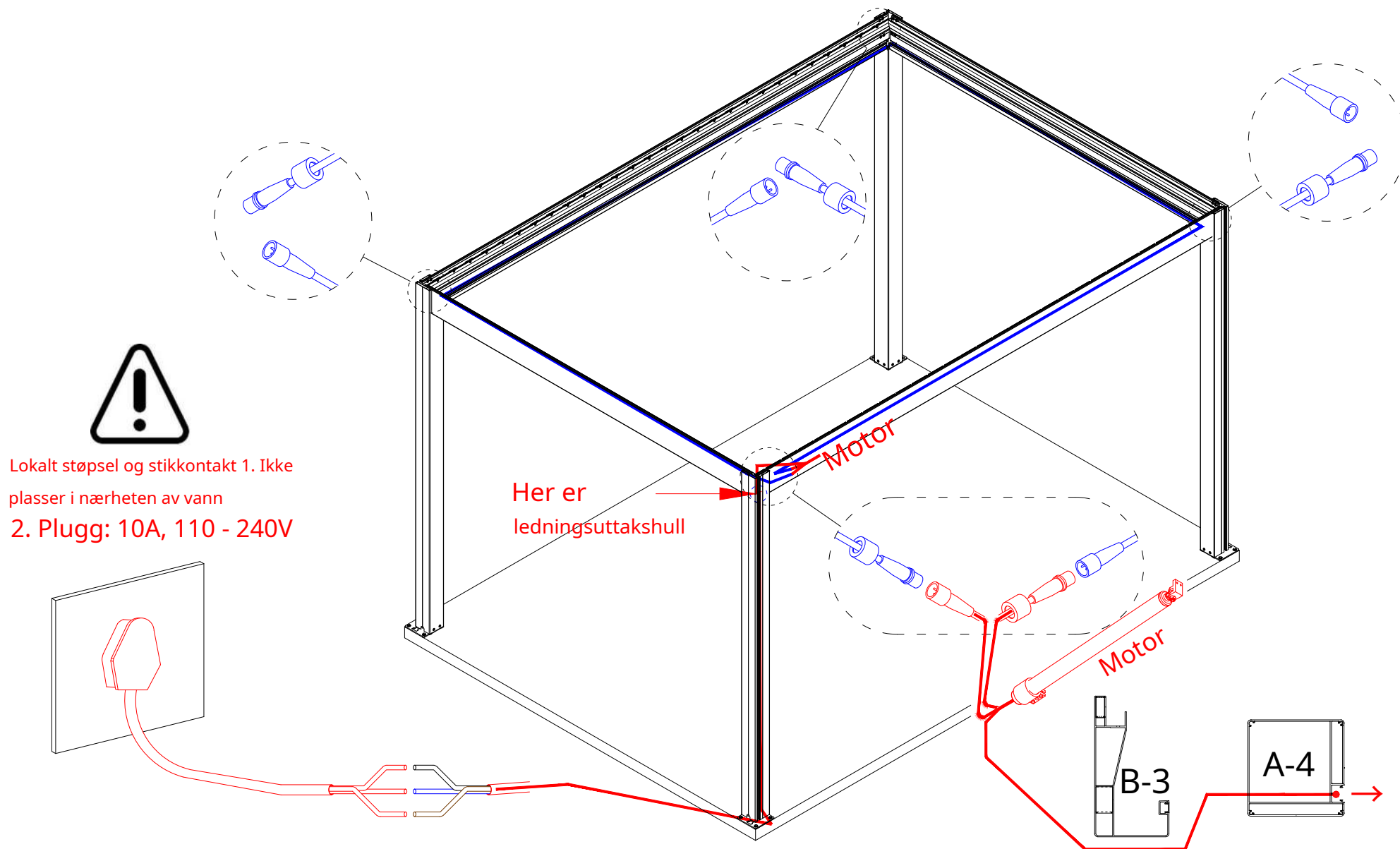



Merk: Følg trinnene for å koble ledningen riktig, ellers vil motoren være defekt.



Støpselet følger ikke med

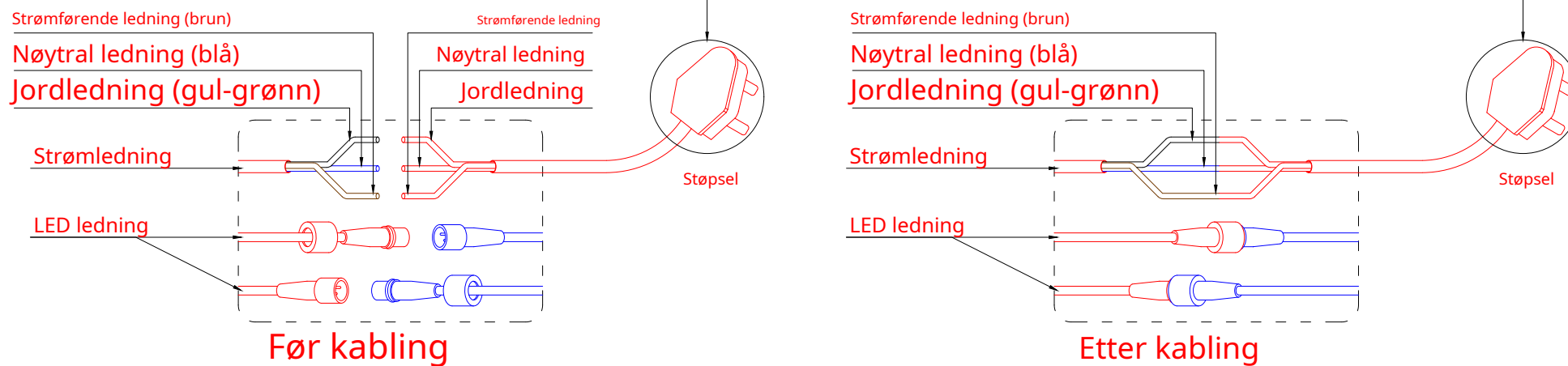

8

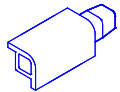

x 4

Fest stolpehjørneforlengelsesstykket

1) Som vist, skyv forlengelsesstykket for stolpehjørnet inn i det øvre av stolpehjørnet.

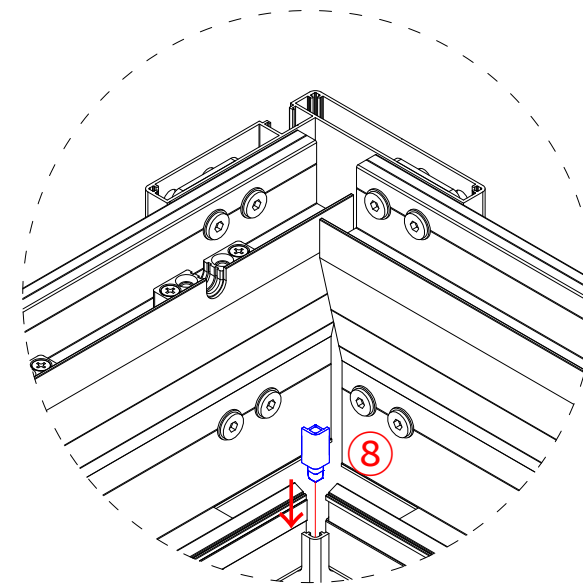
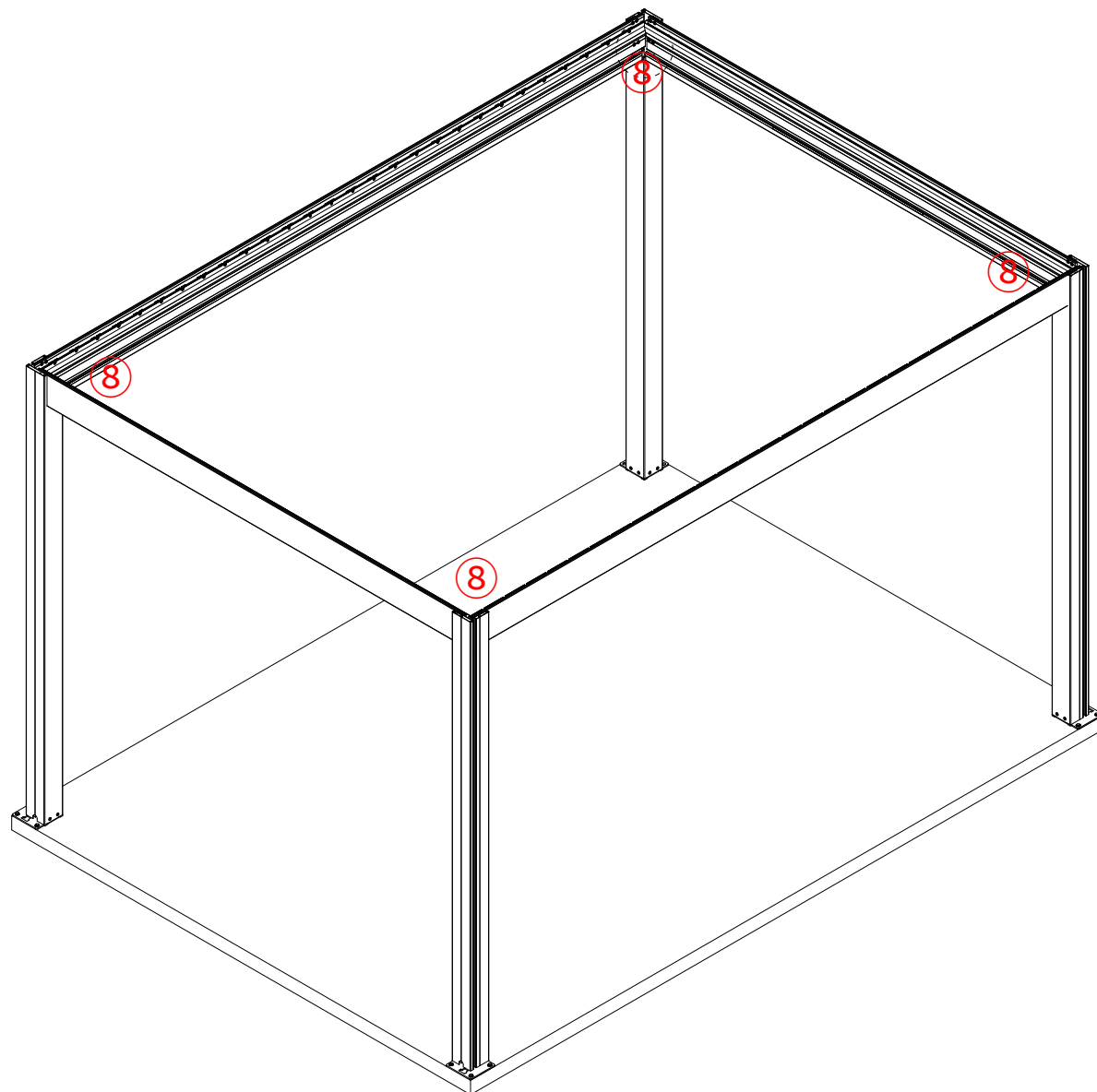

Trinn 1

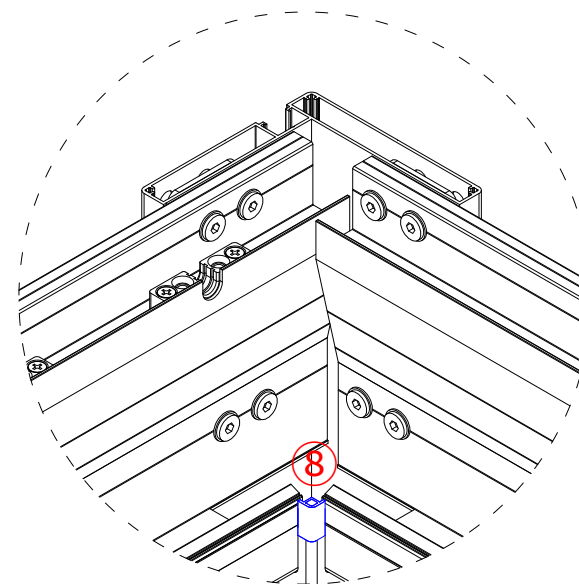

Steg 2

C-1

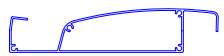

x 1

Installere Louvre

- 1) Som vist klikker motorkoblingsventilen C-1 direkte inn i sporet.
- 2) Koble motorarmbraketten til endekselet til Motor Connecting Louvre C-1.

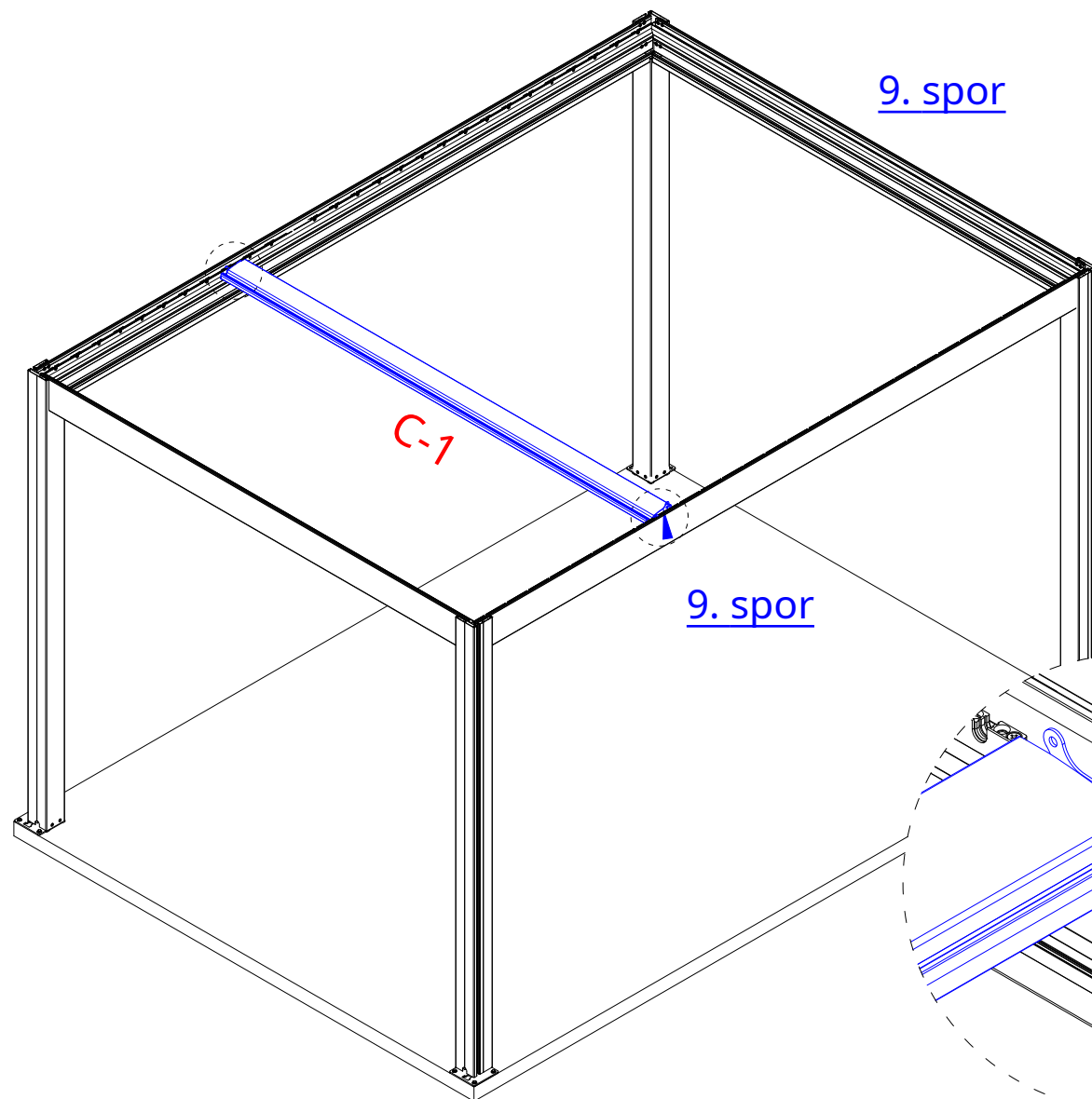

9. spor

C-1

9. spor

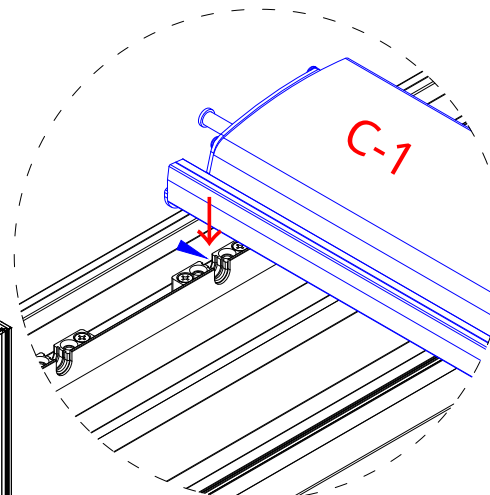

Trinn 1

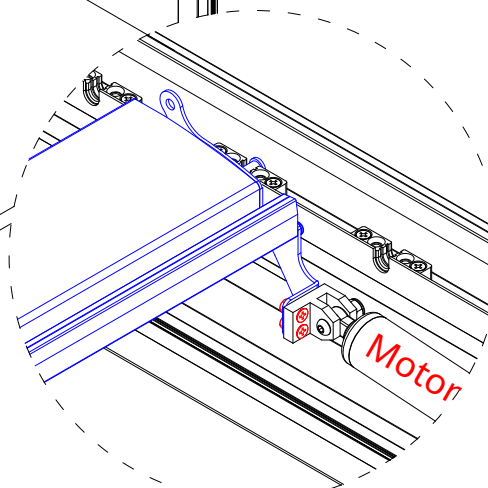

Trinn 3

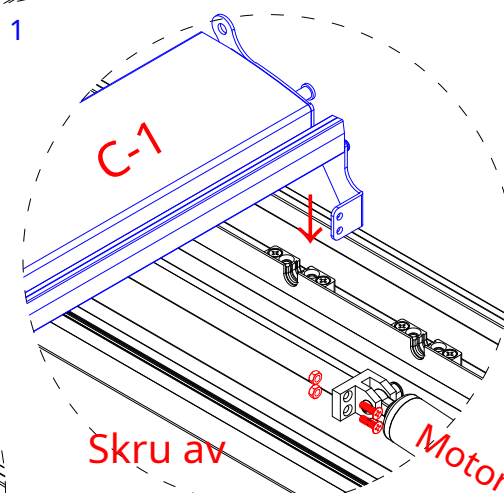

Steg 2

C-2 x 27



Installere Louvre

3) Som vist klikker spjeldet C-2 direkte inn i sporet.

27 stykker
Louvre C-2

C-2

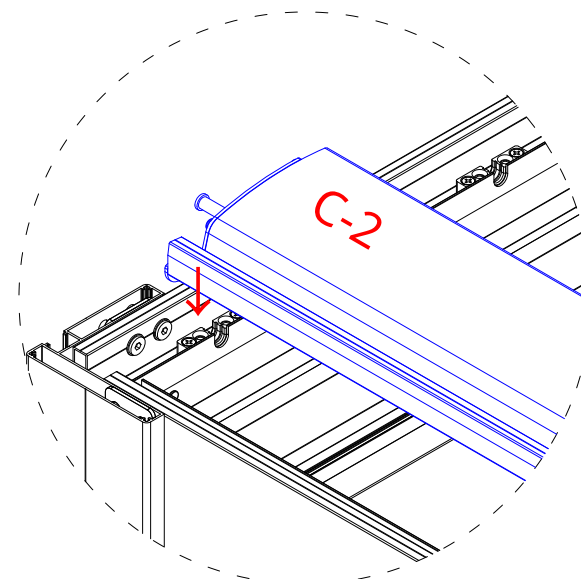
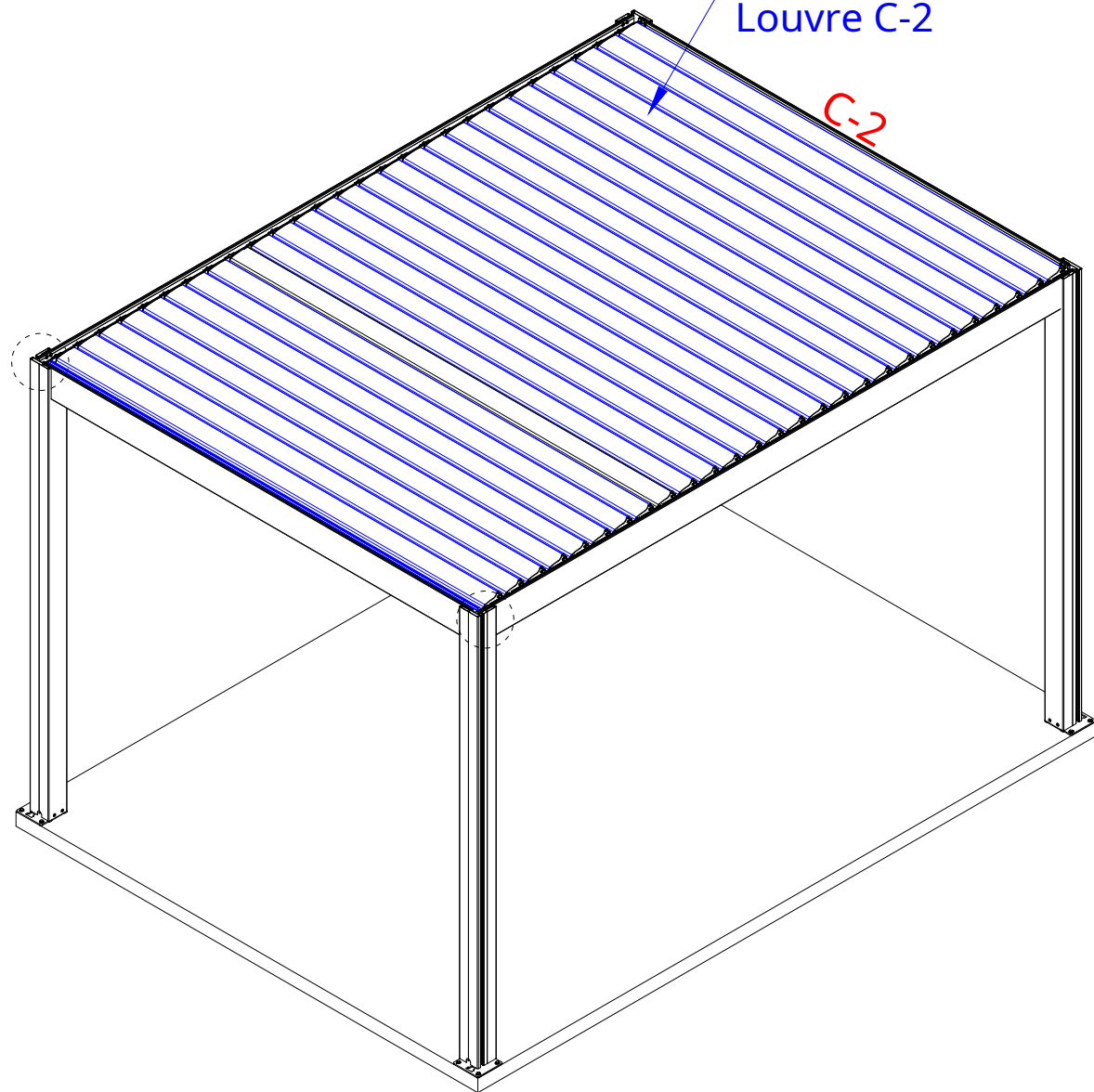

Trinn 1

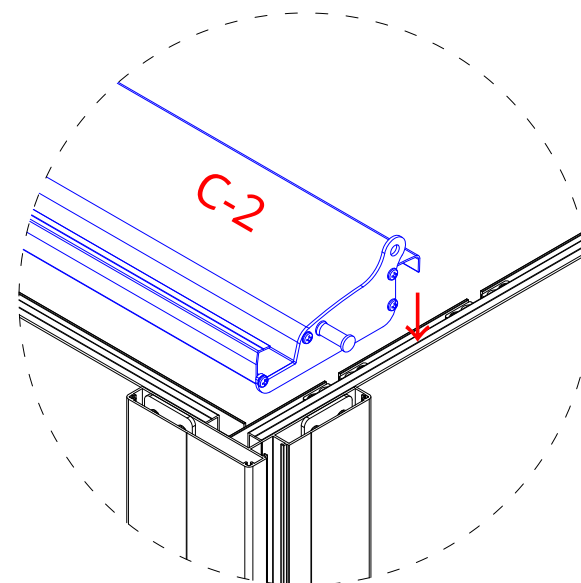

Steg 2

9

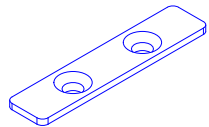

x 56

10



x 112

Installere Louvre

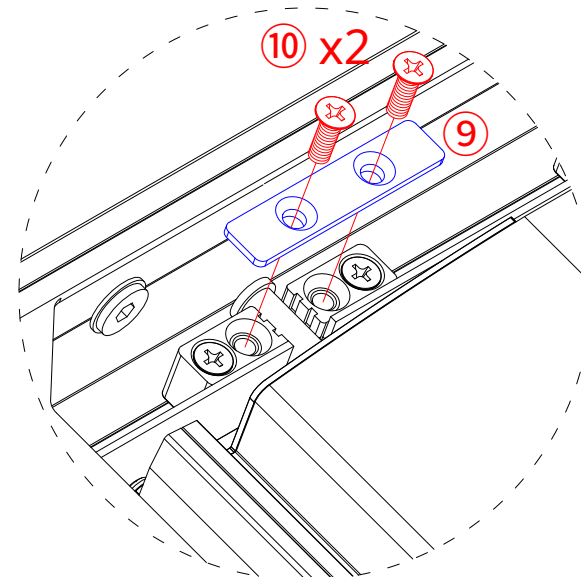
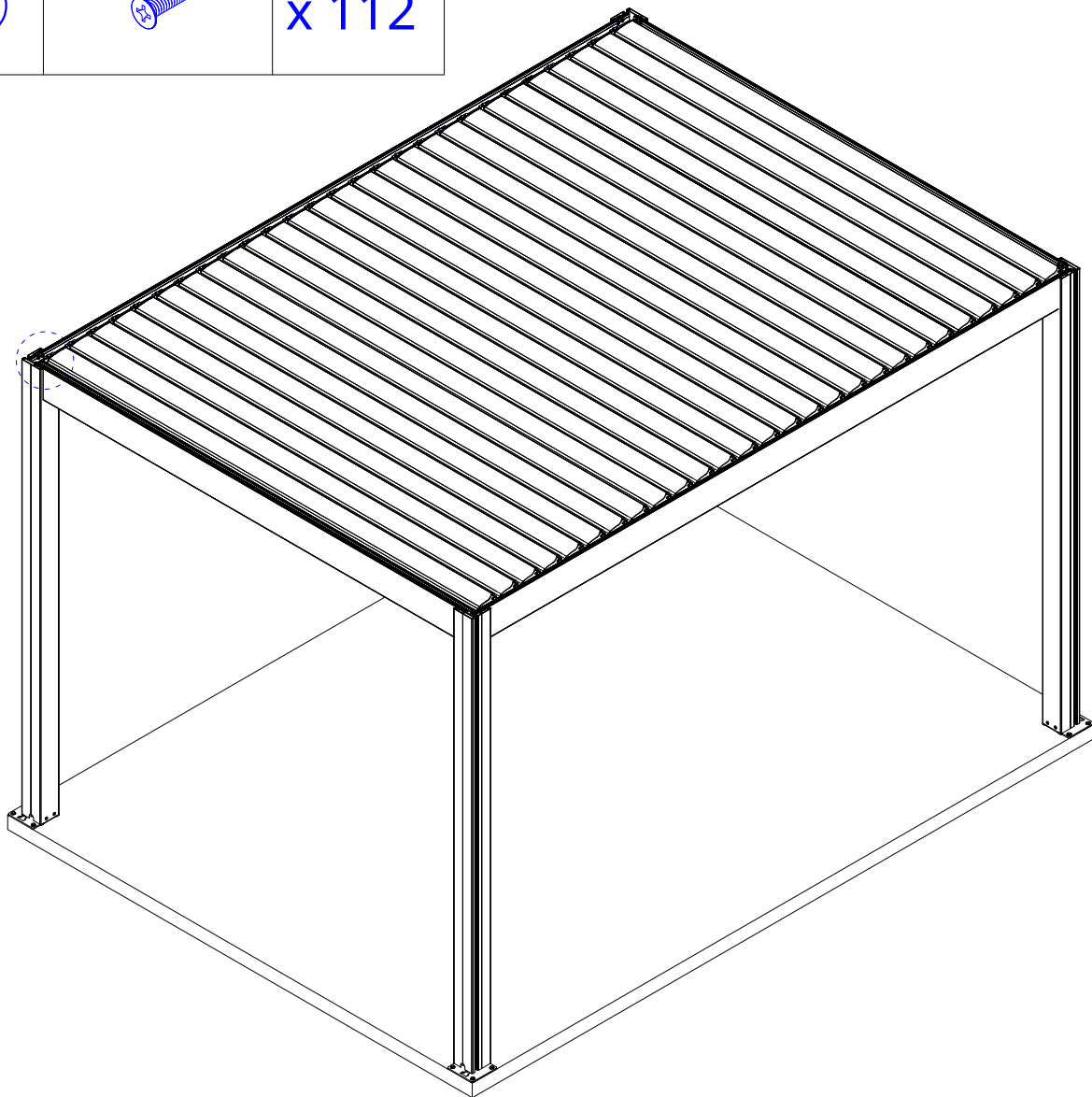

4) Fest akselholderheten som vist 9 på akselholdermed M5*16 Forsenket skrue 10.

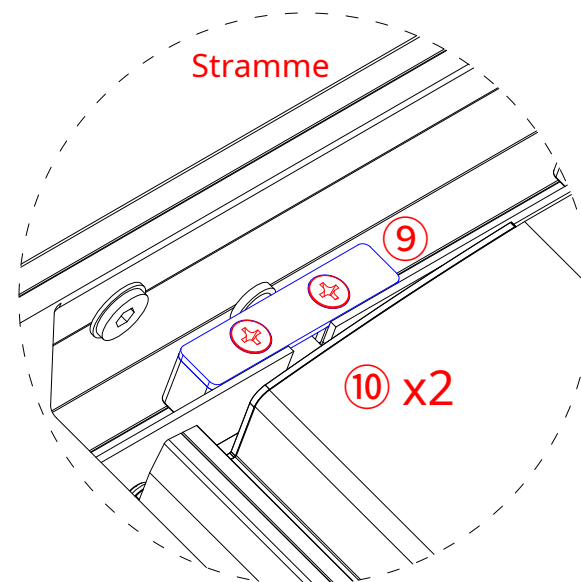

Trinn 1



Steg 2

D		x 1
11		x 28

Installere Louvre

5) Som vist, bruk M6*5 sekskant-tommelskrue 11 gjennom hullet (på kontrollstangen D), deretter festet på rasteret.

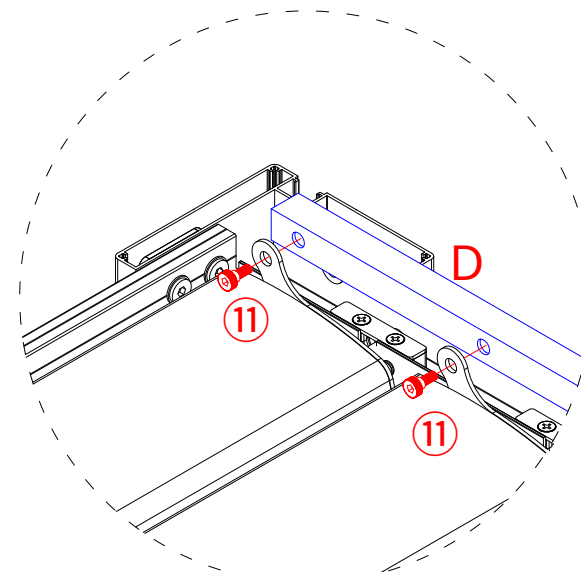
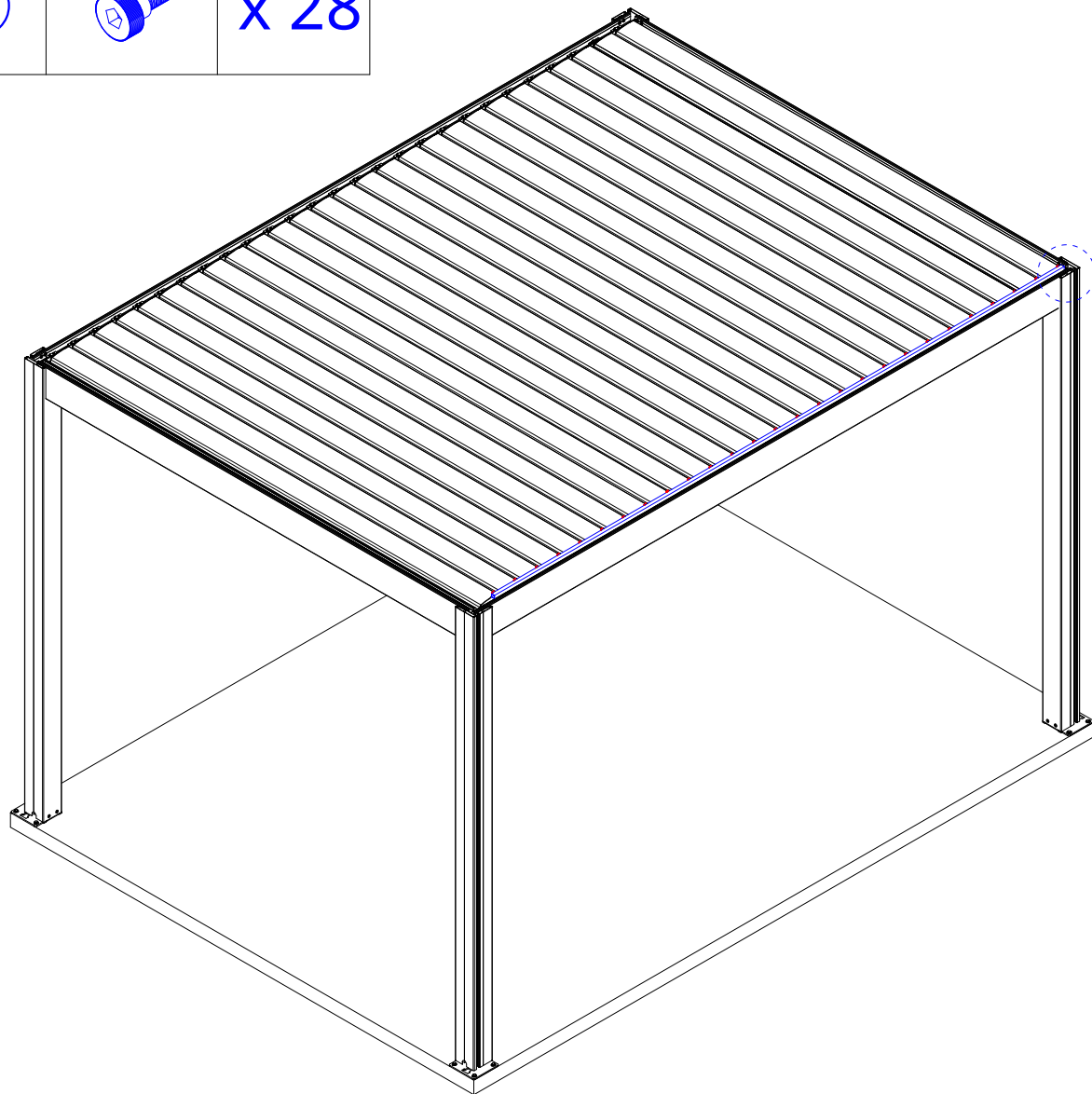

Trinn 1

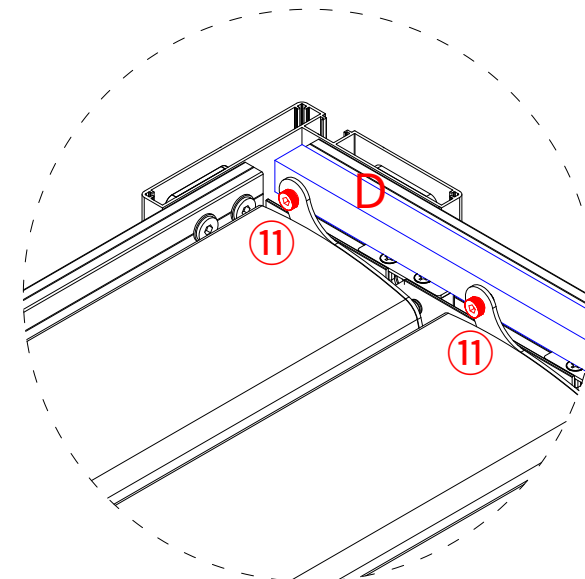

Steg 2

E**x 4**

Fest T-spordekeselet

1) Som vist, sett inn T-spordekeselet E inn i sporet på stolpen.

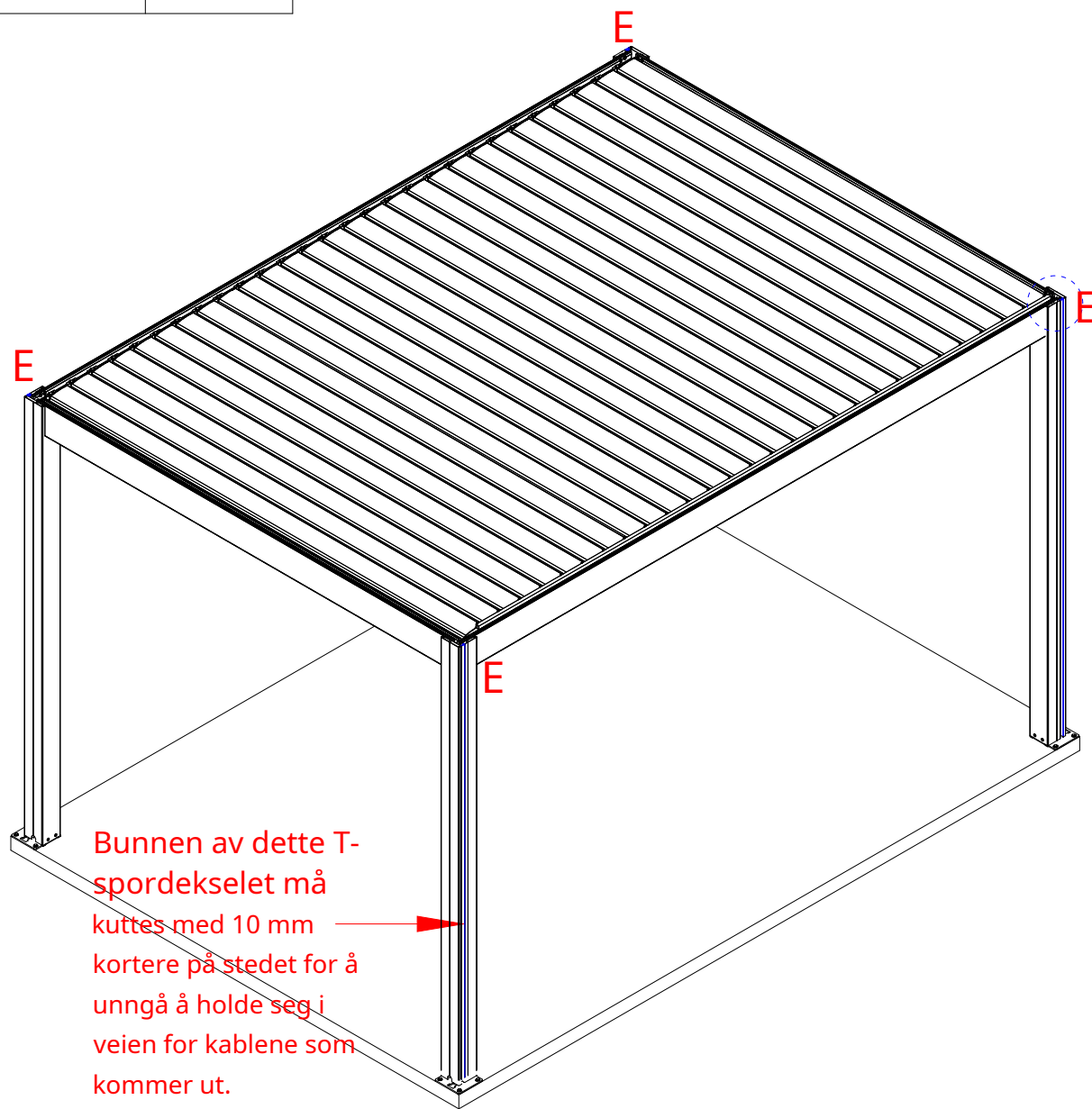

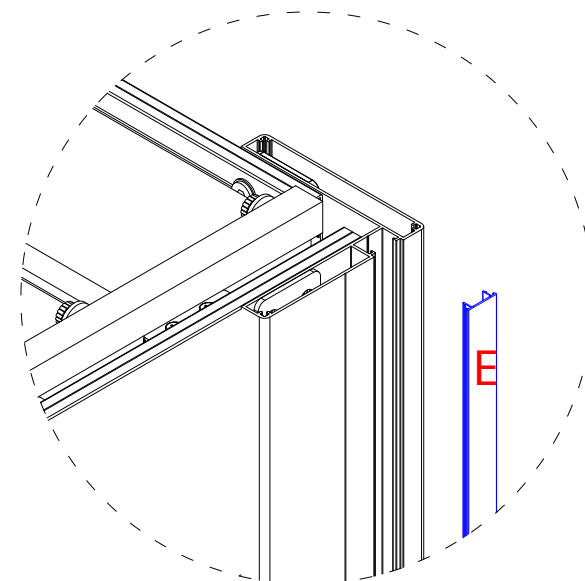

Bunnen av dette T-spordekeselet må kuttes med 10 mm kortere på stedet for å unngå å holde seg i veien for kablene som kommer ut.

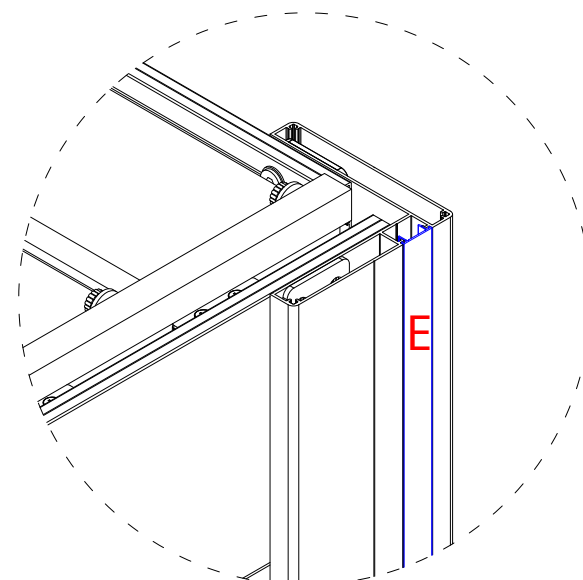

Trinn 1

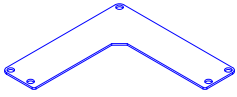

Steg 2

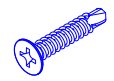
12		x 4
13		x 12
15		x 8

Fest stolpens toppdeksel

2) Som vist, sett på den L-formede endeplaten 12 på toppen av stolpen og fest den deretter med 3 av 4,2*16 selvskruende skruer 13 og 2 av 4,2*19 bor-hale skruer 15.

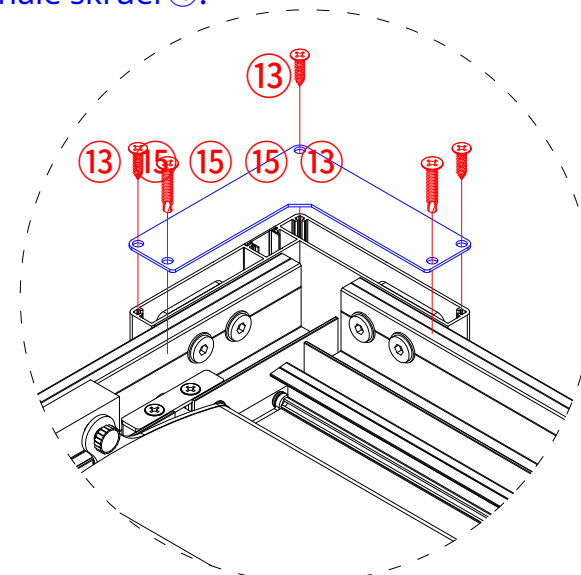
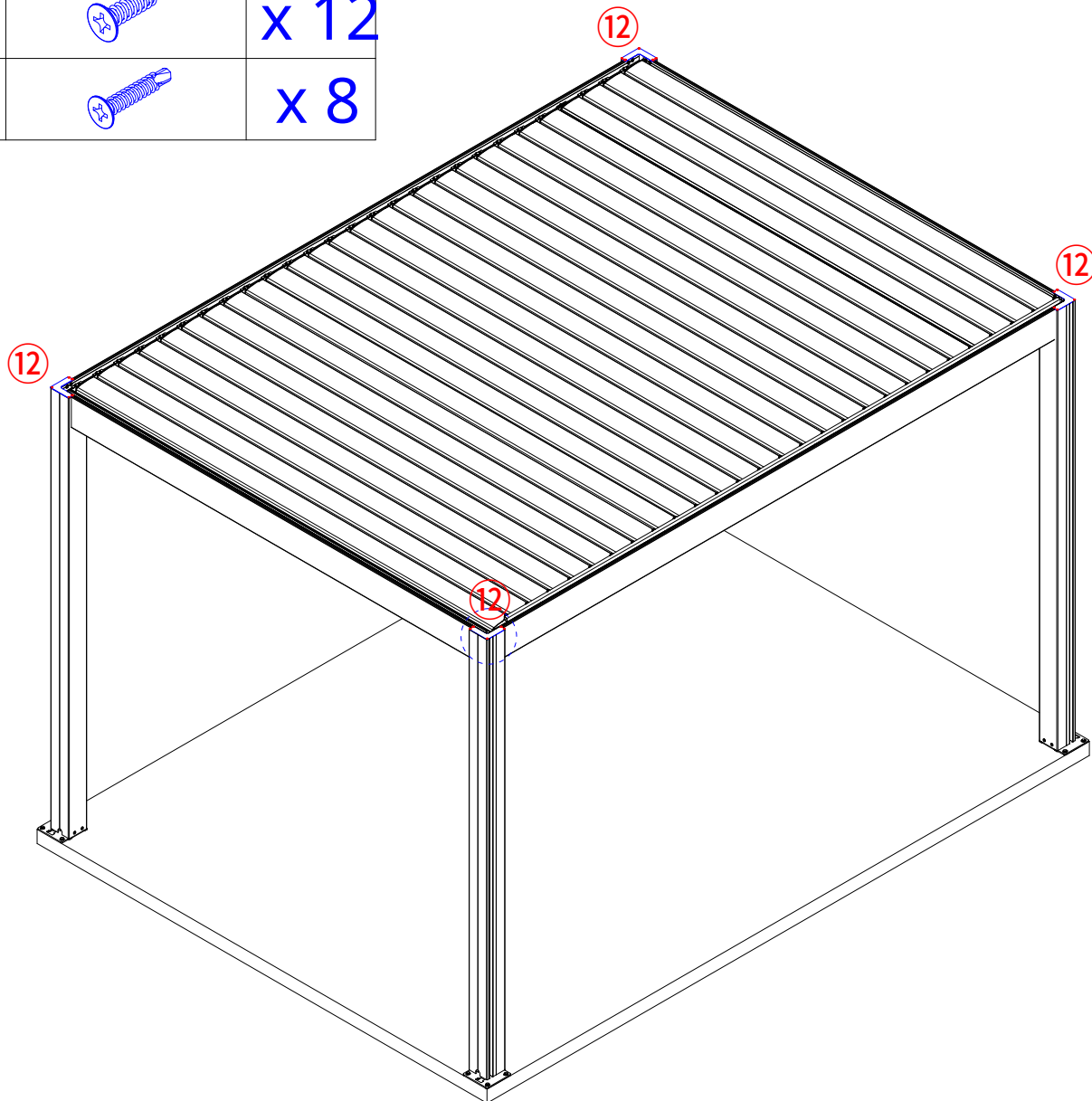

Trinn 1

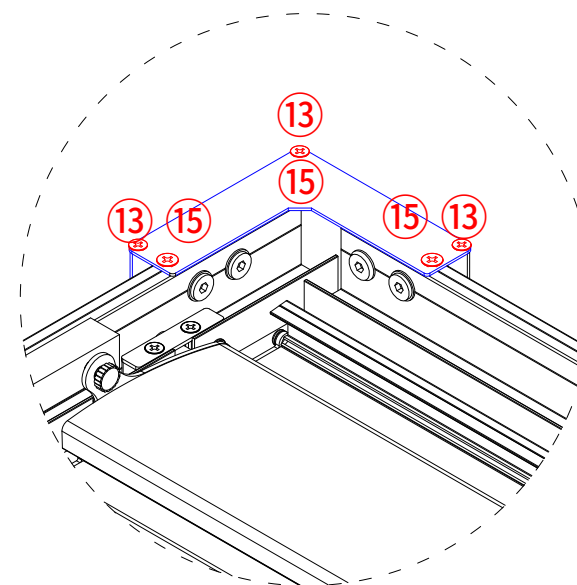

Steg 2

2

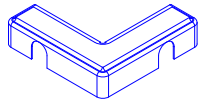

x 4

Montering av bunnplatedekselet

1) Som vist skal det U-formede hakket på bunnplatedekselet være orientert i samme retning som avløpsåpningen. Bunnplatedeksel på stolpe med ekstra utløpsspor.

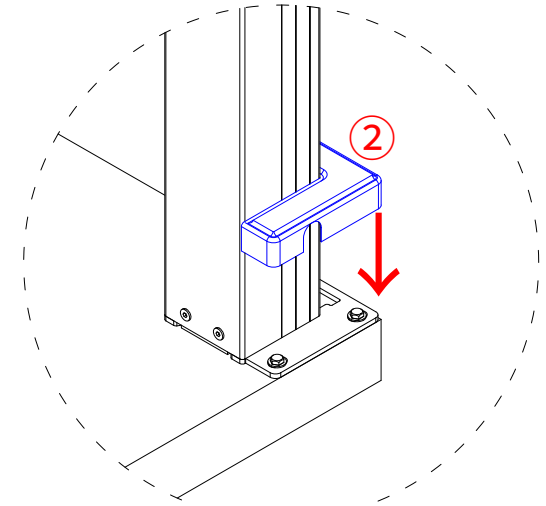
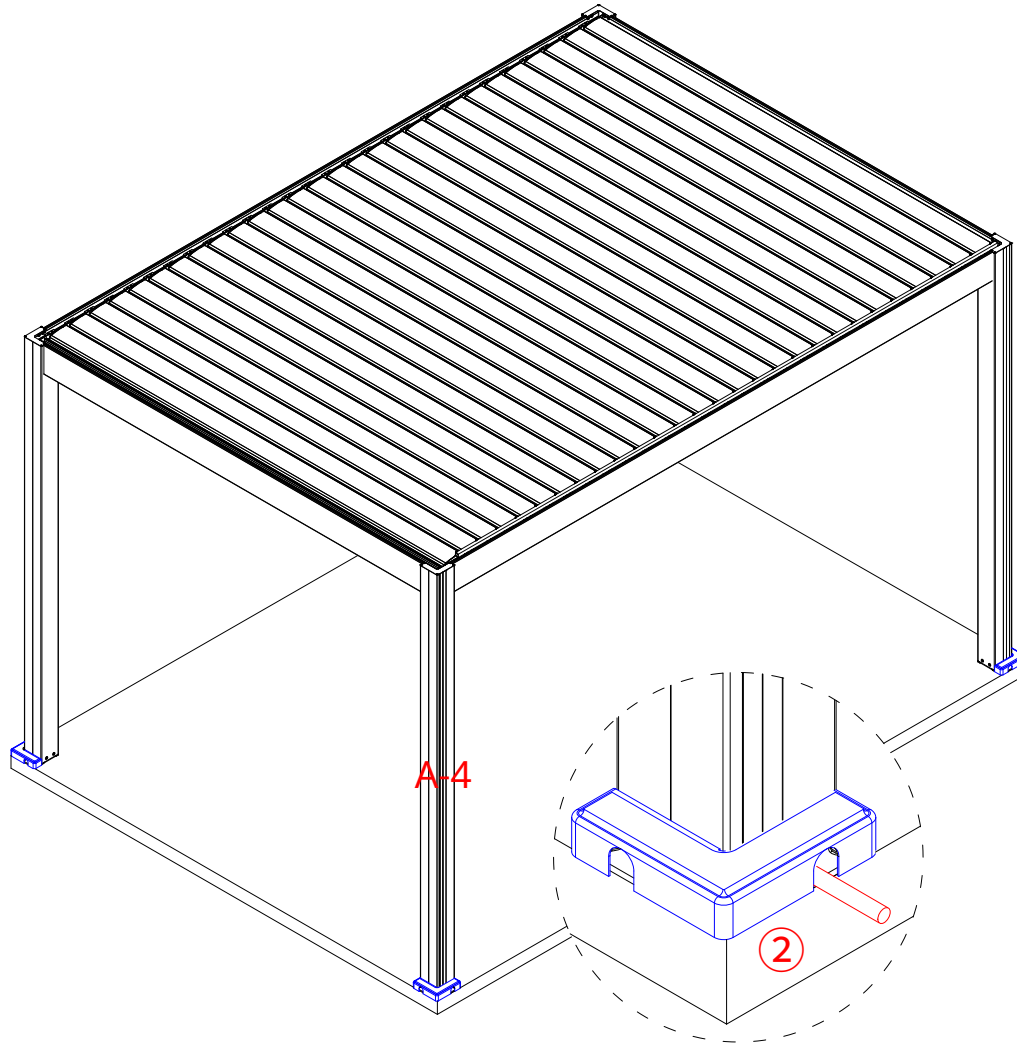

Trinn 1

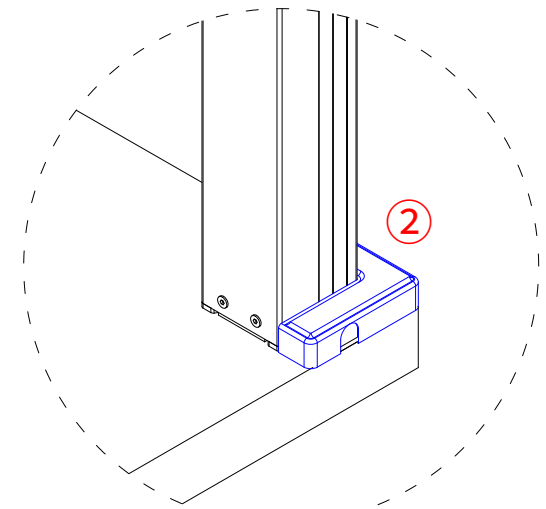

Steg 2

Når fjernkontrollen og mottakeren ikke kan kontrollere motoren, følg trinnene nedenfor for å omprogrammere.

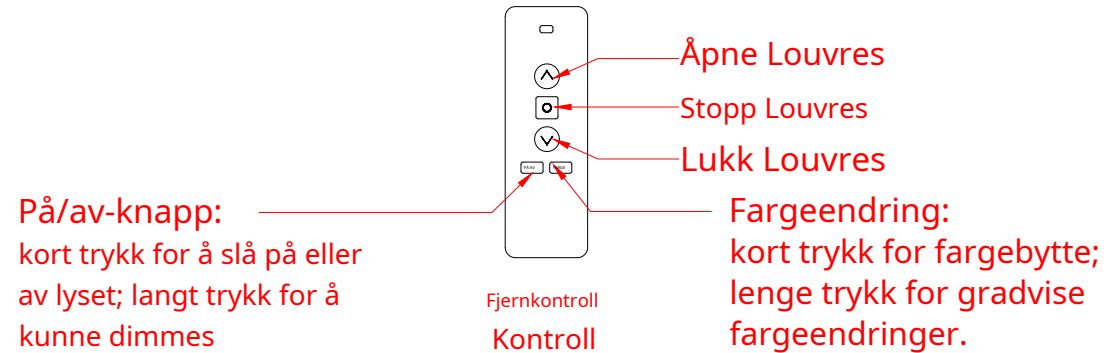

Trinn for sammenkobling:

①

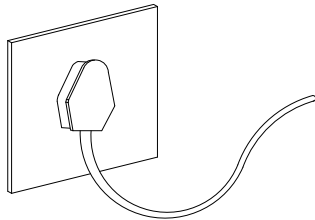

Slå av strømmen i 15 sekunder og koble deretter til strømmen igjen start følgende trinn innen 30 sekunder.

②



Åpne bakdekselet på fjernkontrollen/mottakeren, trykk og hold inne **U2-knapp** i mer enn 7 sekunder.

③

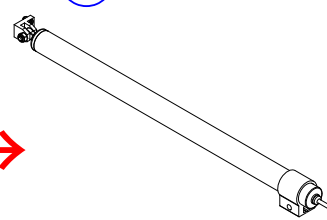

Når motoren fortsetter å lage en "**beepbeepbeep**" lyd.

④

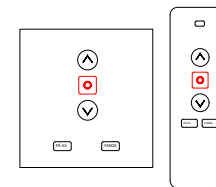

Trykk og hold inne **stoppknapp** på fjernkontrollen/mottakeren i mer enn 2 sekunder igjen. Når "**beepbeepbeep**" lyden fra motoren forsvinner, betyr det at fjernkontrollen/mottakeren har blitt paret vellykket.

Trinn for å endre retning:

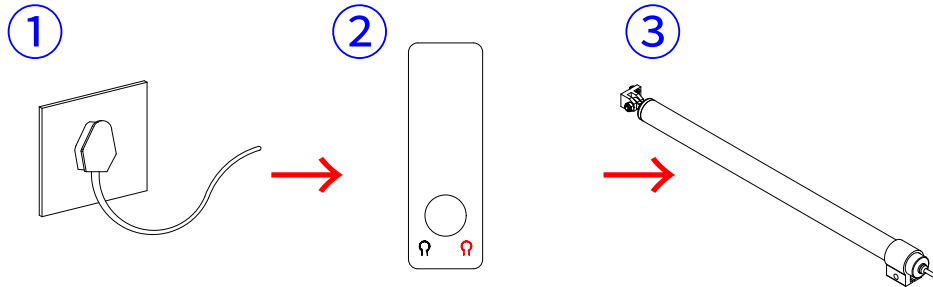

Slå av strømmen i 15 sekunder og koble deretter til igjen kraften altså vennligst start følgende trinn innenfor 30 sekunder.

Åpne bakdekselet på fjernkontrollen/ mottakeren, trykk og hold inne **U2-knapp** i mer enn 7 sekunder.

Når motoren fortsetter å lage en "**beepbeepbeep**" lyd.

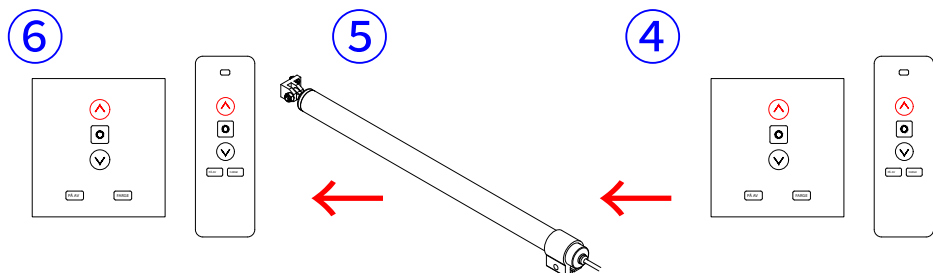

Trykk og hold inne **oppknappen** på fjernkontrollen i mer enn 2 sekunder.

Motoren gjør en "**beepbeepbeep**" lyd igjen

Trykk og hold inne **oppknappen** av fjernkontroll/mottaker for mer enn 2 sekunder.

Paring Slettingstrinn:

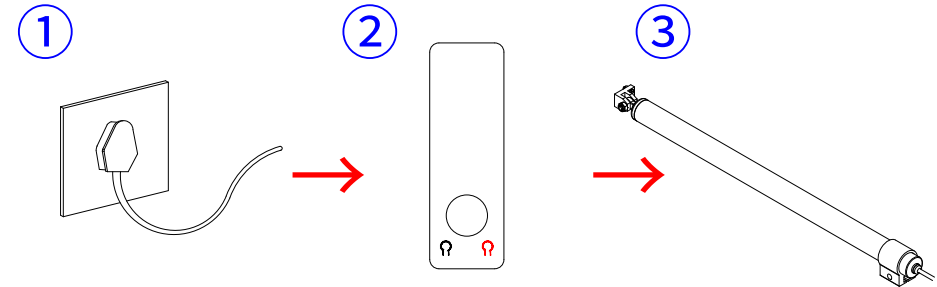

Slå av strømmen i 15 sekunder og koble deretter til igjen kraften altså vennligst start følgende trinn innenfor 30 sekunder.

Åpne bakdekselet på fjernkontrollen/ mottakeren, trykk og hold inne **U2-knapp** i mer enn 7 sekunder.

Når motoren fortsetter å lage en "**beepbeepbeep**" lyd.

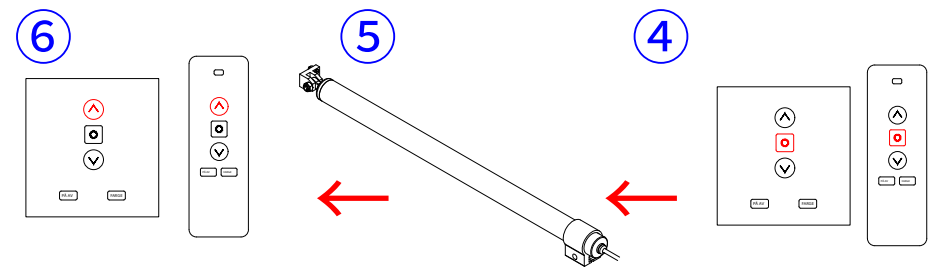

Trykk og hold inne **oppknappen** av fjernkontrollen/ mottakeren for mer enn 2 sekunder. Slett sammenkoblingen vellykket.

Motoren gjør en "**beepbeepbeep**" lyd igjen

Trykk og hold inne **stoppknapp** av fjernkontrollen/ mottakeren for mer enn 2 sekunder.

Ta vare på pergolaen din

Strukturoverflater belagt med termoherdende pulverlakter må rengjøres en gang i året for å opprettholde sitt opprinnelige estetiske utseende.

Termoherdende pulver er følsomme for:

- Fysisk friksjon, hard støt, ekstrudering, kjemikalier inkludert alkalisk løsemiddel og surt løsemiddel.
- Naturlige elementer som vind, regn, snø og langvarig sollys. Utsiden av pergolaen kan forringes over tid og dette vil ikke dekkes av garantien.

Rengjøring av pergolaen din

- Ikke bruk skuresvamp, kremrens, skuresvamp, jerntrådkuler eller fargede kluter.
- Anbefalt: Myk svamp, myk sandfri klut, bomullsull, bomull eller ikke-vevd papir (kun hvitt).
- Ikke bruk etsende produkter som sure eller alkaliske rengjøringsmidler. Det anbefales å vaske med nøytralt pH vaskemiddel og deretter tørke av det med en klut for å holde det tørt.
- Ved rengjøring med høytrykksutstyr må de samme forholdsreglene tas som ved rengjøring av karosseriet: avstand, dysetype, vanntemperatur og trykk bør alle vurderes.

Bruk påminnelse

- Etter at installasjonen er fullført, kontroller at skruene er stramme. Husk å sjekke skruene minst en gang i året.
- **I tilfeller der det er spådd snøfall, hagl eller sterk vind over 80 km/t, anbefales det å åpne lamellbladene. Ikke bruk knivene i tilfelle frost eller snø. Vennligst fjern bladene fra pergolaen når snøen er rikelig.**
- Kontroller tetningsforholdene regelmessig for å sikre at tetningene eller andre komponenter ikke lekker.
- Rydd regelmessig opp rusk som fallne løv på pergola for å forhindre blokkering av avløpet.
- Bruksbegrensninger: Vanntette systemer er, selv om de er effektive, ikke designet for å sikre fullstendig vanntetting. Kraftig regn og sterk vind kan skade pergolaen. Eventuelle skader dekkes ikke av garantien.

INSTRUKCJA OBSŁUGI

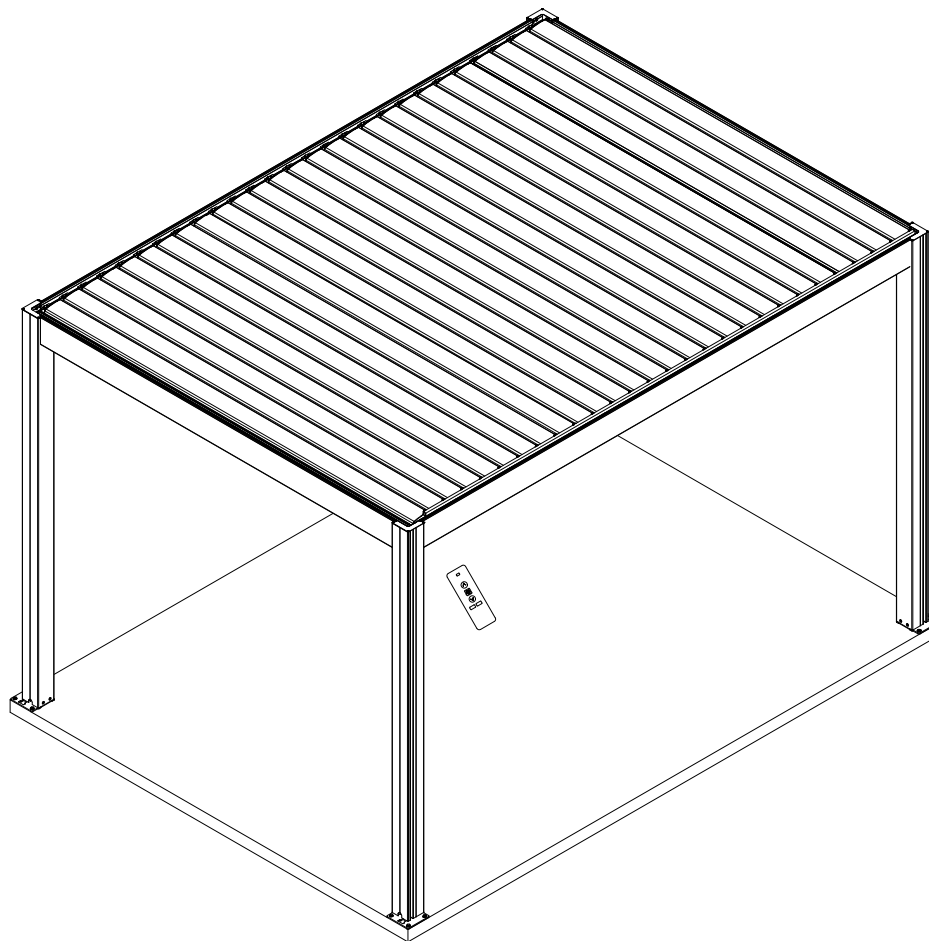

OTHER LANGUAGES

Pergola 4x2,86M

Przed pierwszym użyciem pergoli prosimy o zapoznanie się z niniejszą instrukcją.

Prosimy zachować niniejszą instrukcję do wykorzystania w przyszłości.

Pergola

Otwarcie: Elektryczny

Rozmiar: 295.3 (Długość) x 409 (Szerokość) -cm

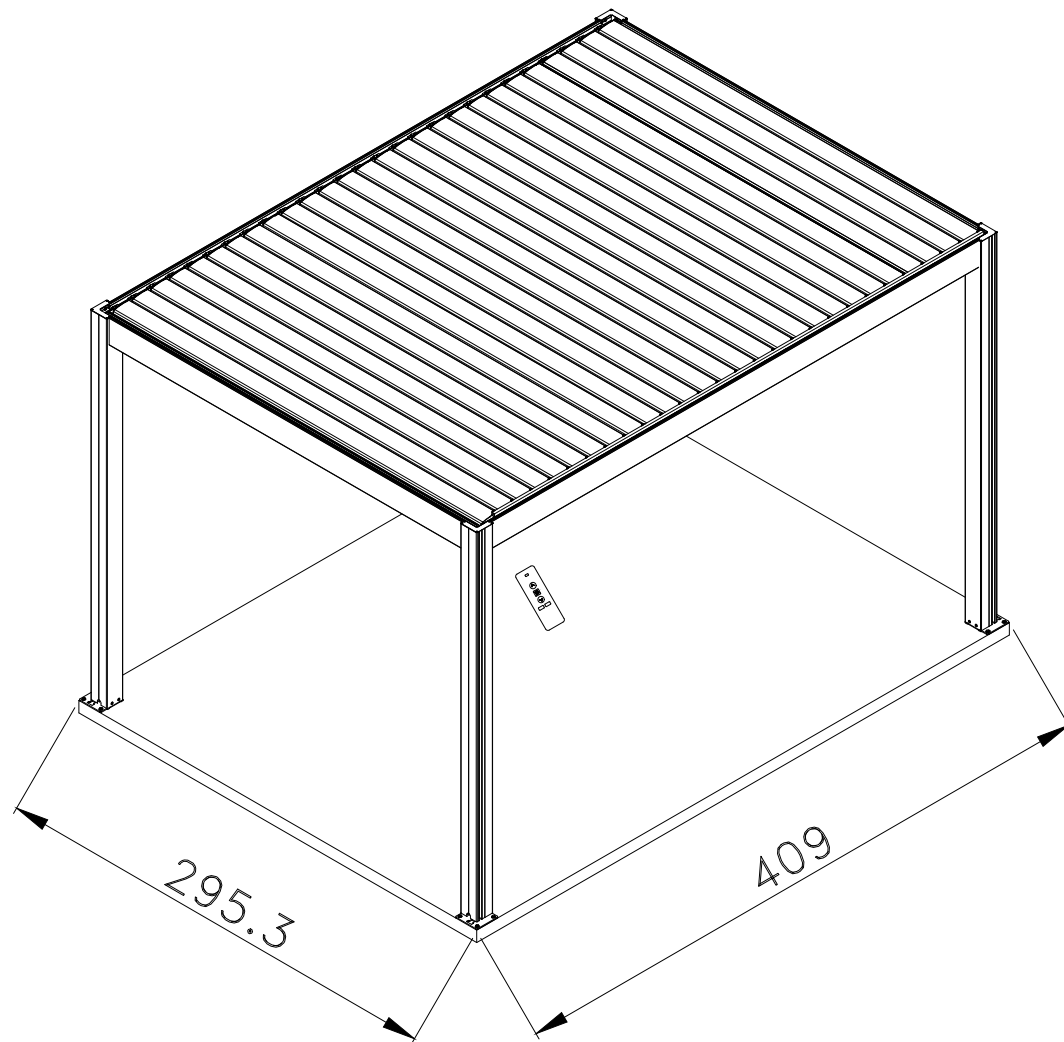

Uwagi dotyczące instalacji:

1. Do montażu potrzebne są minimum trzy osoby: jedna do pomiaru i znakowania, jedna do montażu i jedna jako pomocnik.
2. W zestawie znajdują się wyłącznie łączniki do podłóg betonowych. W przypadku braku płyty betonowej na podłożu zaleca się wykonanie płyt betonowych przy każdym słupie. Płyta betonowa powinna mieć min 500x500x500mm.
3. Po zmontowaniu ramy pergoli użyj kwadratu, poziomicy i linijki, aby zmierzyć poziom produktu i przekątną, aby sprawdzić rozmiar pergoli. Podstawy muszą być dokładnie wypoziomowane, bez tolerancji.
4. Pergolę należy przykręcić do podłoża. Nie bierzemy żadnej odpowiedzialności za pęknięcie płytek podczas wiercenia śrub.
5. Niezbędne są elektronarzędzia: upewnij się, że działają prawidłowo i postępuj zgodnie z instrukcjami bezpieczeństwa.
6. Zachowaj ostrożność podczas używania ostrych narzędzi.
7. Nosić odzież ochronną, w tym okulary ochronne, hełmy i rękawice.
8. Nie wspinaj się ani nie stój na dachu.

- . Podczas montażu zdecydowanie zaleca się noszenie rękawiczek.
- . Nie instaluj pergoli podczas złych warunków pogodowych, takich jak wiatr lub deszcz.
- . Nie dotykaj przewodów profilami aluminiowymi.
- . Podczas montażu pergoli należy zawsze nosić obuwie ochronne i okulary.
- . Wszystkie plastikowe torby należy przechowywać poza zasięgiem dzieci.
- . Kolumnę pergoli należy ustawić i zamocować na płaskiej powierzchni.
- . Nie opieraj się o kolumnę podczas fazy montażu.
- . Nie pozwalaj dzieciom zbliżać się do miejsca zdarzenia w fazie montażu.
- . Nie zbliżaj się do pergoli podczas burzy lub tajfunu.
- . Nie próbuj wspinać się na pergolę pod wpływem alkoholu lub narkotyków.
- . Korzystając z drabin lub podobnych narzędzi i elektronarzędzi na etapie montażu, należy przestrzegać zaleceń producenta dotyczących bezpieczeństwa.
- . Żadne gorące narzędzie, np. wiertarka elektryczna, nie może mieć kontaktu z profilem pergoli.
- . Przed ustawieniem kolumny upewnij się, że pod ziemią nie znajdują się żadne kable ani inne kable.

Ogólna rada

- . Ta pergola składa się z kilku elementów, a jej montaż zajmuje co najmniej 90 minut. Pergoli nie należy ustawiać pod drzewem.
- . Jeśli podłączasz kolumnę bezpośrednio do cementu lub podobnego podłoża, użyj wstępnie wycięte otwory w dostarczonej podstawie.
- . Przed montażem sprawdź ilość profili i okuć i zastosuj je zgodnie z wykazem okuć profilowych, aby ułatwić montaż.
- . Włóż małe kawałki, takie jak śruby, do pojemnika, aby uniknąć strat.
- . Proszę zwrócić uwagę na położenie przekładni na belce, aby uniknąć nieprawidłowego umieszczenia.
- . Regularnie czyść pergolę z liści, śniegu i innych przedmiotów.

Konserwacja i naprawa

- . Do czyszczenia pergoli użyj łagodnego detergentu i spłucz wodą. Do czyszczenia powierzchni profilu aluminiowego nie należy używać acetonu ani ściernych środków czyszczących.

Gwarancja

- . Ogólna gwarancja na przebarwienia wynosi 5 lat, na silnik i oświetlenie LED 2 lata.

Narzędzia zabezpieczające i instalacyjne

Sprzęt ochronny:

1. Kask
2. Rękawiczki
3. Apteczka pierwszej pomocy
4. Okulary ochronne



Przyrząd pomiarowy:

1. Taśma miernicza (5 metrów lub więcej)
2. Linijka kwadratowa
3. Poziom

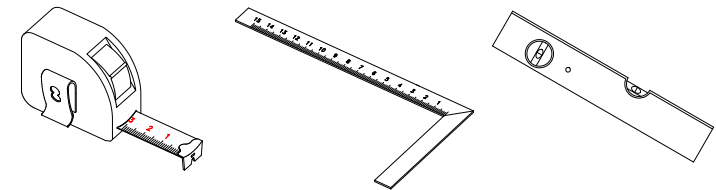



Narzędzia:

1. Drabina 2 metry (1,5 metra lub więcej)
2. Klucz imbusowy 13 mm
3. Klucz imbusowy 17 mm
4. Wiertarka elektryczna
5. Wiertarka elektryczna (wierćto 10 mm)
6. Marker lub ołówek
7. Młotek gumowy
8. Pistolet do uszczelniania i klejenia





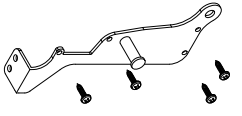
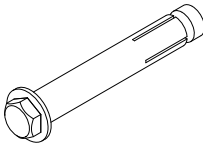
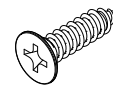
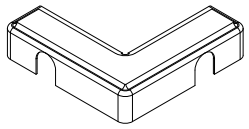
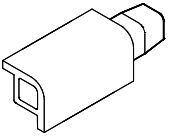
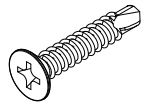
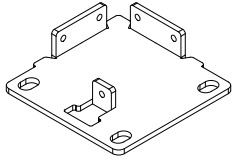
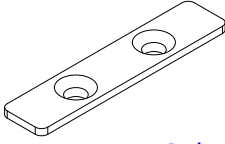
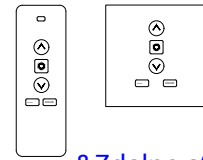
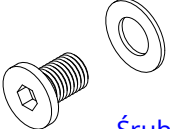

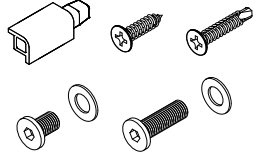
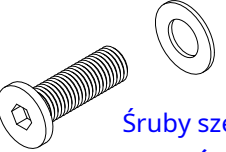
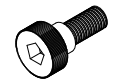
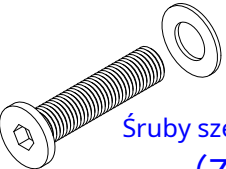
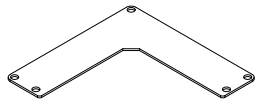
Silicon

Lista akcesoriów i śrub

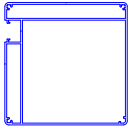
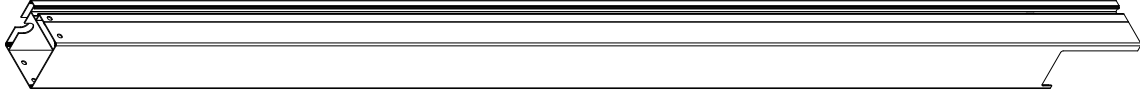
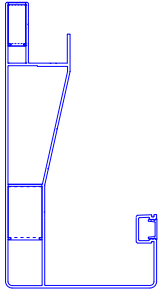
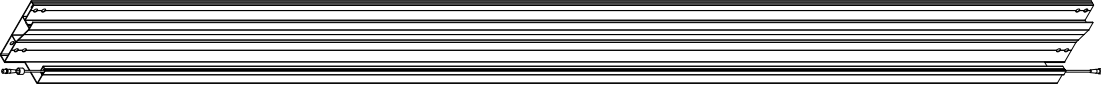
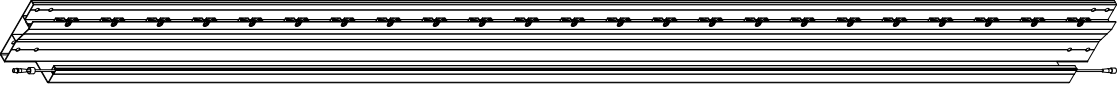
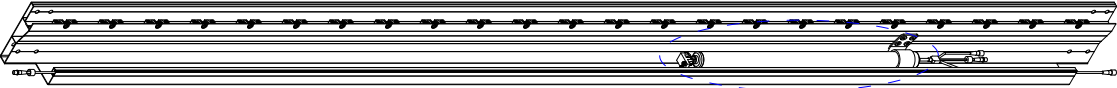
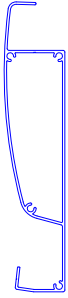
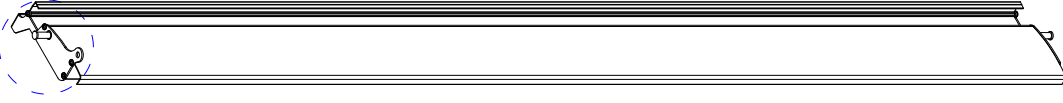
<p>①</p>	 <p>x 1 Zaślepka do Raster łączący silnik i śruby z łbem płaskim 4*20</p>	<p>⑦</p>	 <p>x 16 Śruba rozporowa M8*80</p>	<p>⑬</p>	 <p>x 12 Śruba z łbem płaskim 4,2*16</p>
<p>②</p>	 <p>x 4 Osłona płyty podstawy</p>	<p>⑧</p>	 <p>x 4 Kącik pocztowy Element przedłużający</p>	<p>⑭</p>	 <p>x 8 Śruba wiertarska 4,2*19</p>
<p>③</p>	 <p>x 4 Płyta podstawowa</p>	<p>⑨</p>	 <p>x56 Osłona uchwytu wału</p>	<p>⑮</p>	 <p>x 1 Odbiorca &Zdalne sterowanie dachowe</p>
<p>④</p>	 <p>x 16 Śruby sześciokątne M8*12 (Z podkładką)</p>	<p>⑩</p>	 <p>x 112 Śruba stożkowa M5*16</p>	<p>⑯</p>	 <p>x 1 Części zamienne</p>
<p>⑤</p>	 <p>x 16 Śruby sześciokątne M8*25 (Z podkładką)</p>	<p>⑪</p>	 <p>x28 Śruba motylkowa M6*5 sześciokątna</p>	<p>⑰</p>	
<p>⑥</p>	 <p>x 16 Śruby sześciokątne M8*35 (Z podkładką)</p>	<p>⑫</p>	 <p>x 4 Górna pokrywa słupka L</p>	<p>⑱</p>	

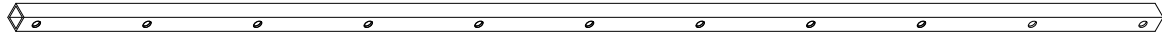
Lista profili

<p>A-1 ~ A-4</p>			<p>x 4 Post</p>
<p>B-2 B-4</p>			<p>x 2 Belka i rynna</p>
<p>B-1</p>			<p>x 1 Belka i rynna (z uchwytem wału)</p>
<p>B-3</p>			<p>x 1 Belka i rynna (z uchwytem wału) + silnik</p>
<p>C-1</p>			<p>x 1 Luwrow łączący silnik</p>
<p>C-2</p>			<p>x27 Żaluzja</p>
<p>D</p>			<p>x 1 Pręt sterujący</p>
<p>mi</p>			<p>x 4 Osłona rowka T</p>

Profile aluminiowe przedstawiają rysunek

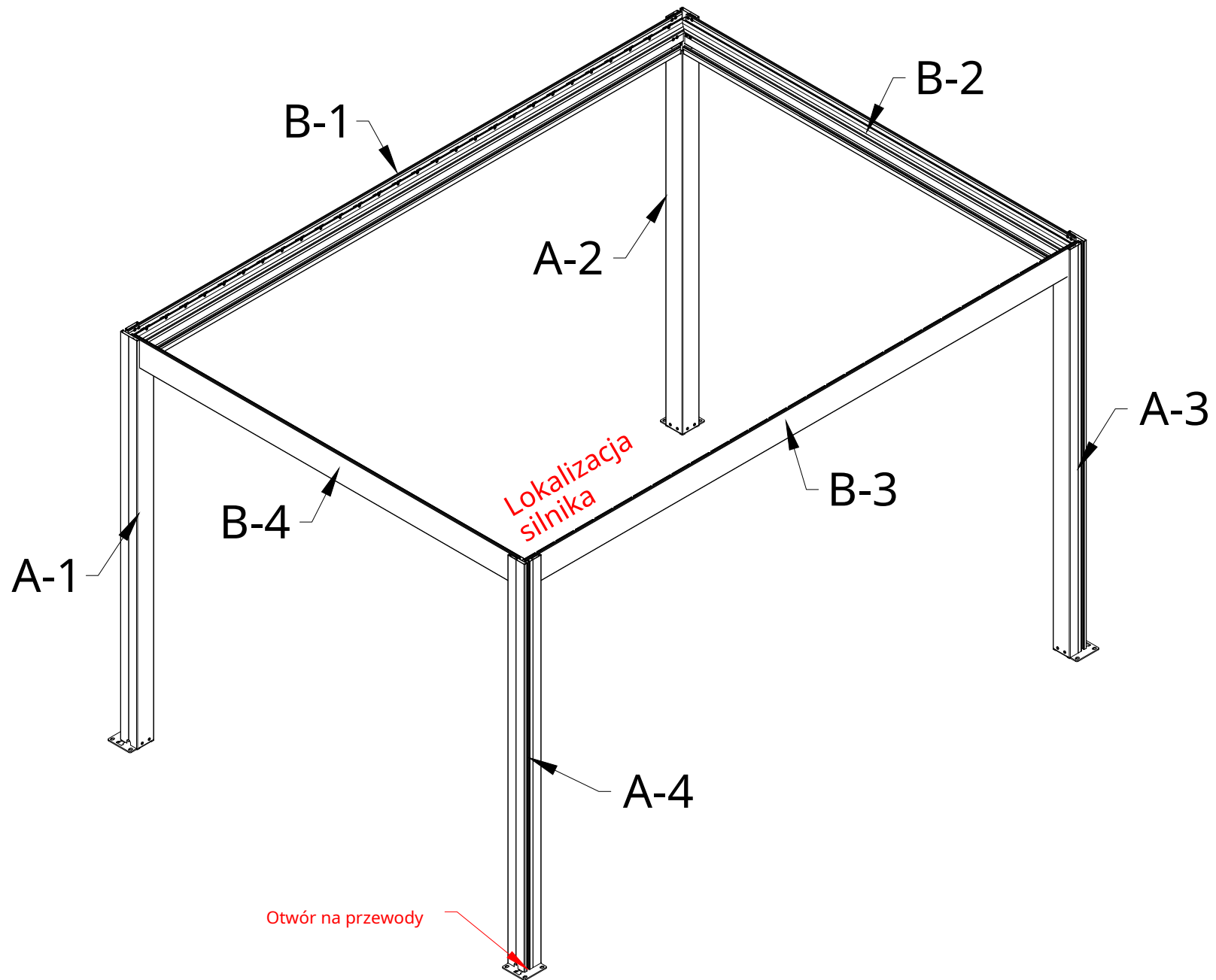

1

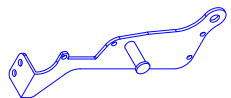

x 1



x 4

Instalowanie żaluzji łączącej silnik

1) Przymocowano osłonę ostrza na żaluzji łączącej silnik C-1 za pomocą śrub z łbem płaskim 4*20.

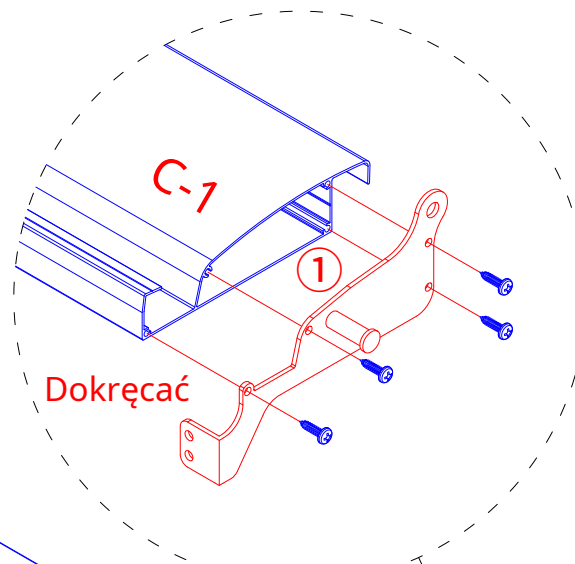

Krok 1

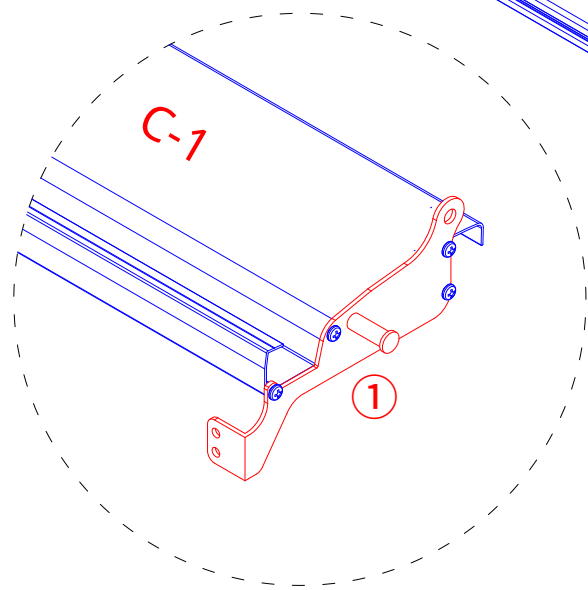

Krok 2

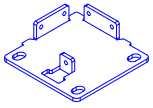
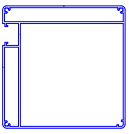
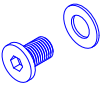

Jeżeli miejsce montażu jest ciasne, osłony ostrzy można zamontować po zamontowaniu ramy.

③		x 4	A-1 ~ A-4		x 4
④		x 16			

Złóż ramę

1) Jak pokazano, włóż pokrywę płyty podstawy ② w posty, następnie wyrównaj otwory w płycie podstawy ③ z otworami w słupkach i zablokuj płytę podstawy ③ do słupków za pomocą śrub sześciokątnych M8*12 (z podkładką) ④.

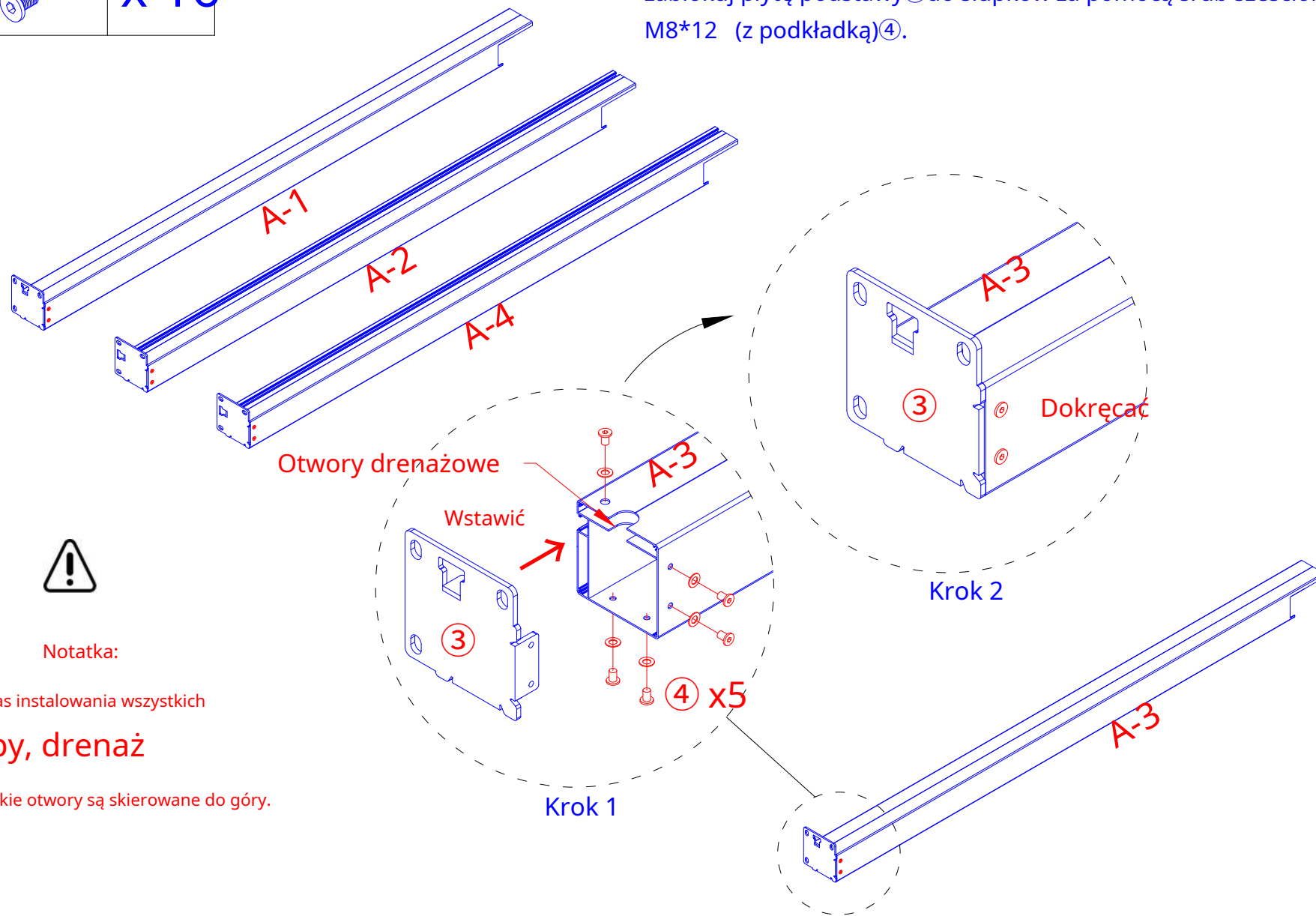

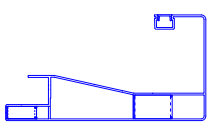
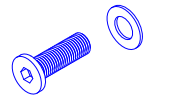
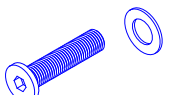
B-1 B-3		x 2
⑤		x 8
⑥		x 8

Złóż ramę

2) Jak pokazano, włóż belkę i rynnę (B-1, B-3) w posty, następnie naprawiłem belkę i rynnę (B-1, B-3) na słupkach za pomocą śrub sześciokątnych M8*25^⑤ i śruby sześciokątne M8*35^⑥.

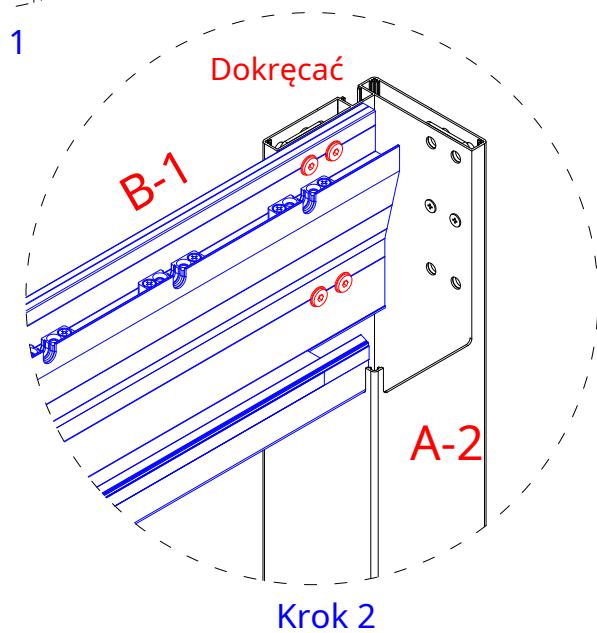
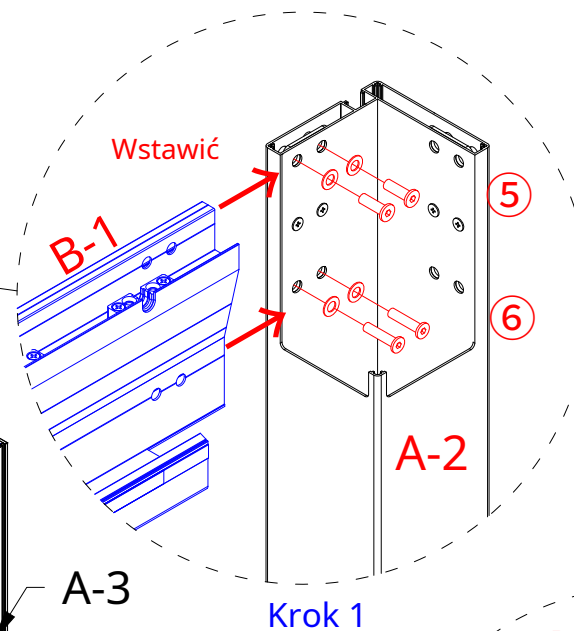
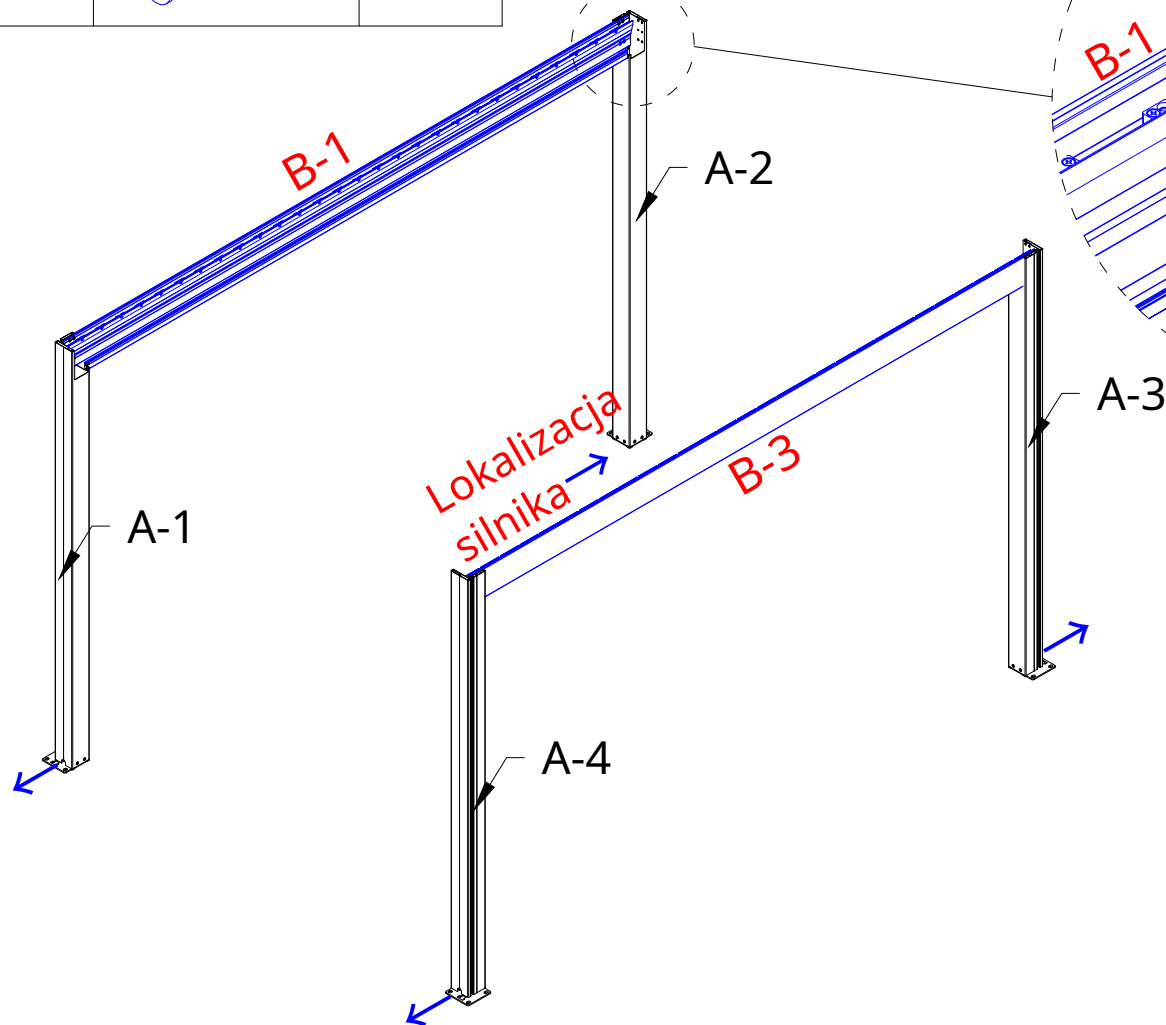

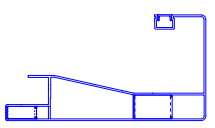
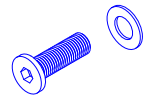
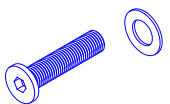
B-2 B-4		x 2
5		x 8
6		x 8

Złóż ramę

3) Jak pokazano, włóż belkę i rynnę B-2, B-4 w posty, następnie naprawiłem belka i rynna B-2, B-4 na słupkach za pomocą śrub sześciokątnych M8*25⁵ i śruby sześciokątne M8*35⁶.

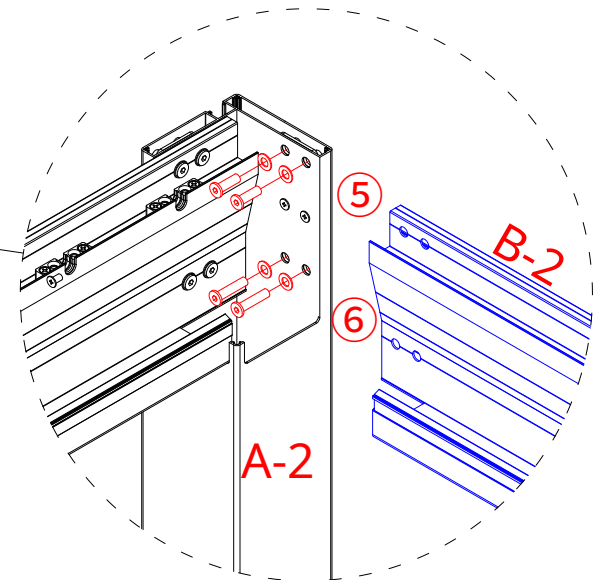
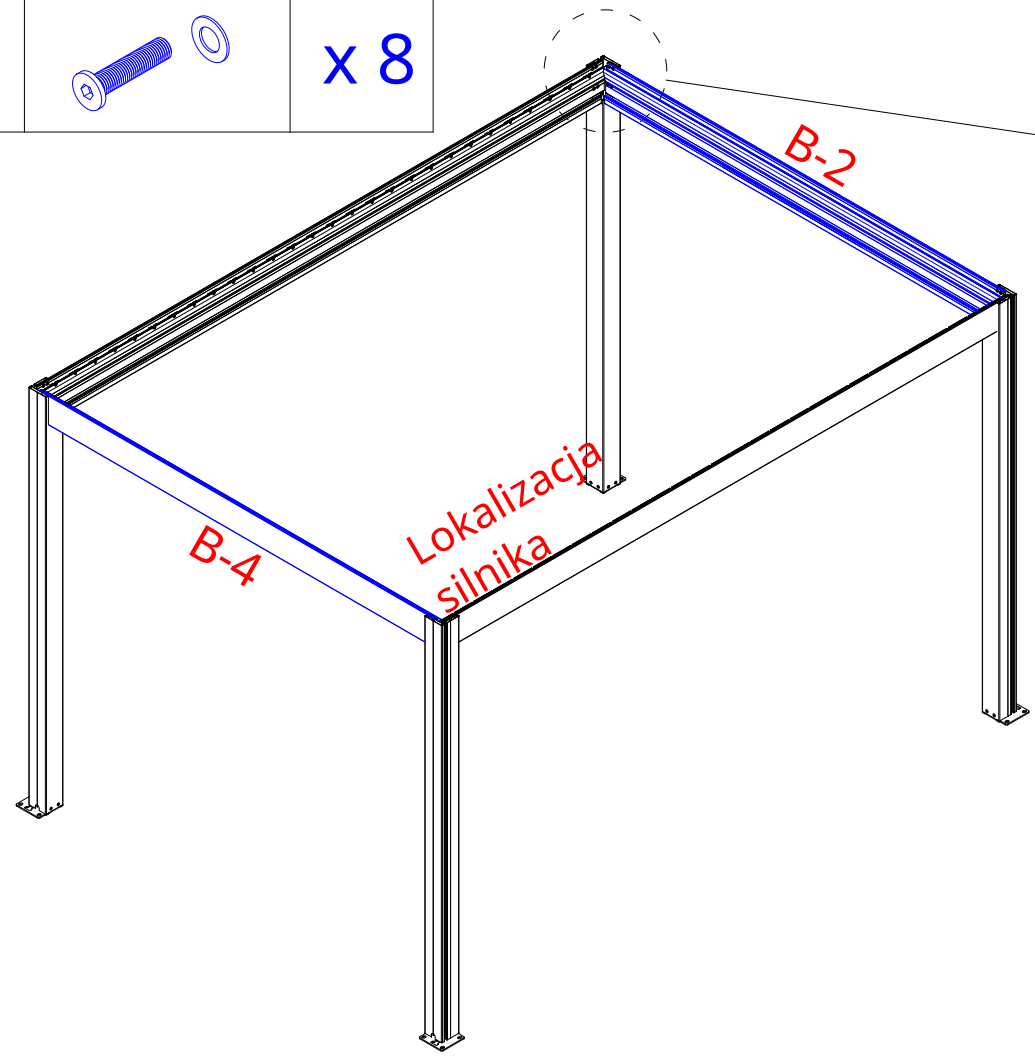

Krok 1

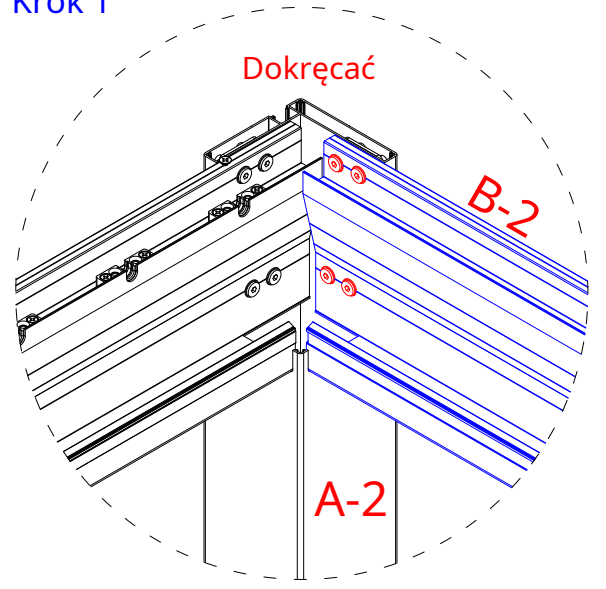

Krok 2

7

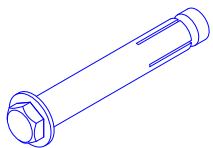

x 12

Notatka:

Przed zamocowaniem płyty podstawy należy upewnić się, że przekątne 4 słupków mają tę samą długość. Upewnij się, że rozmiar $W1=W2, W3=W4$.

Przymocuj pergolę do podłoża

- 1) Użyj śruby rozporowej 12 M8*80⑦ pod warunkiem, że podłożem jest podłoga betonowa. Jeśli nie, będziesz musiał znaleźć inne rozwiązanie, aby przykręcić pergolę do wybranej powierzchni.
- 2) Przesuń pergolę do odpowiedniej pozycji montażowej, następnie zaznacz ołówkiem położenie czterech słupków, zdejmij pergolę i za pomocą wiertarki elektrycznej wykonaj 12 otwory zgodnie z oznaczeniem. Przesuń pergolę z powrotem na miejsce i zabezpiecz płytę podstawy za pomocą śruby rozporowej M8*80⑦.

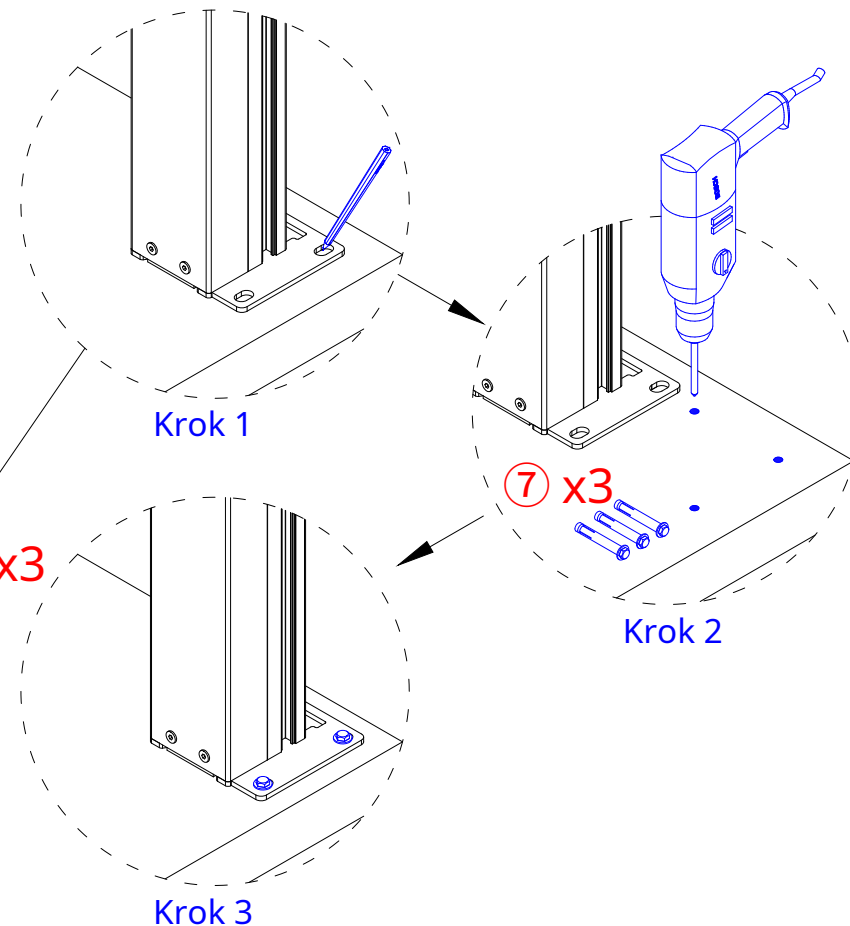
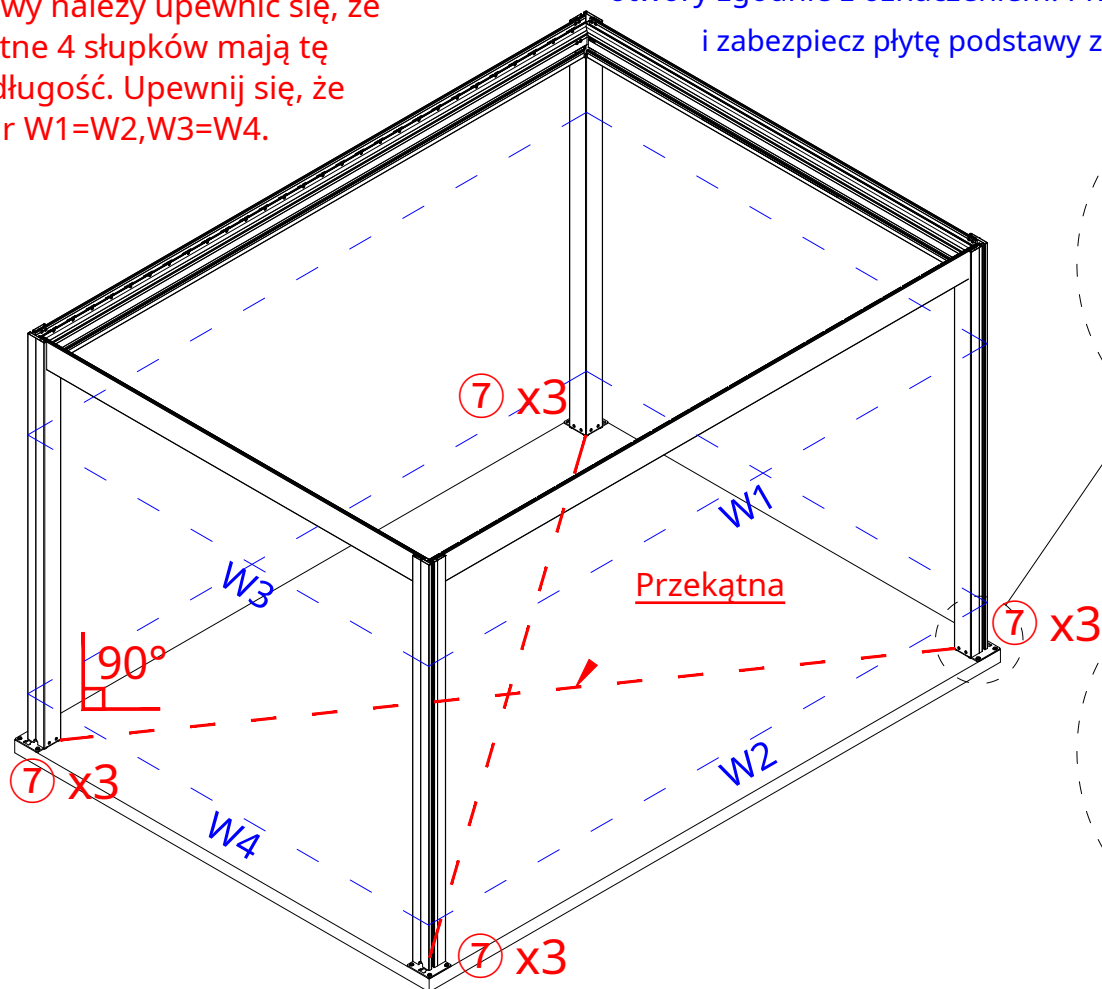

Za zamocowanie pergoli odpowiada użytkownik. Producent nie ponosi odpowiedzialności za uszkodzenia pergoli (lub jej akcesoriów) spowodowane klęskami żywiołowymi lub zdarzeniami szczególnymi. Każda pergola, która nie jest zamocowana, może zostać wysadzona w powietrze i spowodować uszkodzenia, za co odpowiedzialność nie będzie ponoszona przez producenta. Regularnie sprawdzaj pergolę, aby upewnić się, że pozostaje stabilna i mocno przymocowana do podłoża. Pergola, która odłączy się od swojej pozycji i spowoduje lub spowoduje uszkodzenie, nie będzie objęta gwarancją.

 **Drut LED**

 **Linia napięciowa**

Prowadzenie przewodów

Układając przewody wsuń je w słupek od wycięcia na górnym końcu słupka, następnie przeciągnij przewody do otworu wylotowego, następnie wyciągnij przewody z gniazdka i na koniec wyjdź z otworu na dole postu.

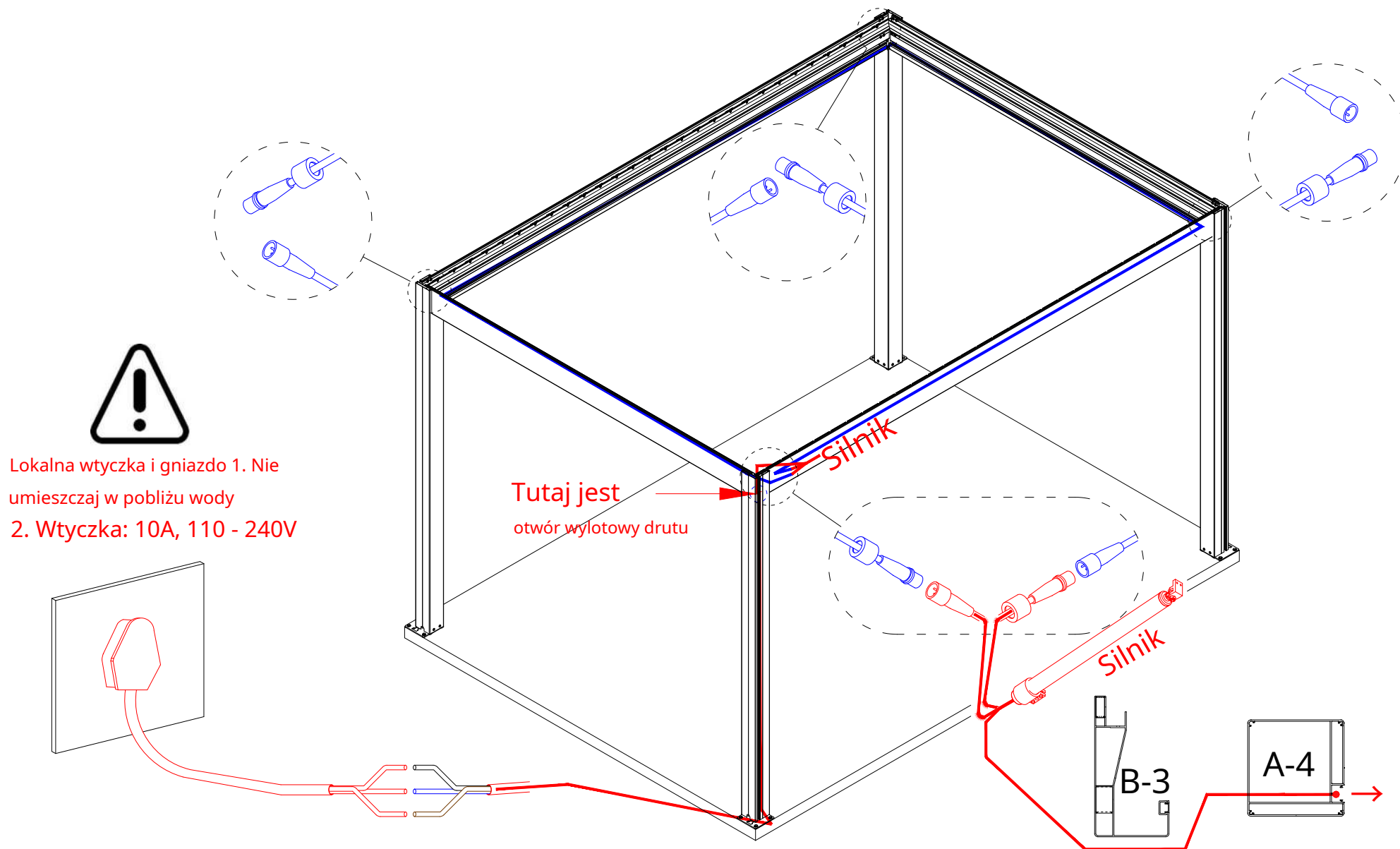



Uwaga: Postępuj zgodnie z instrukcjami, aby prawidłowo podłączyć przewód, w przeciwnym razie silnik będzie uszkodzony.



Wtyczka nie jest dostarczana

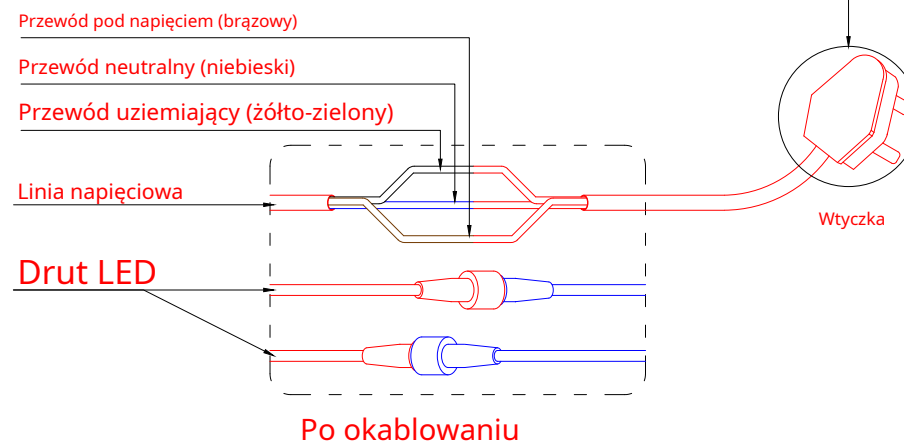
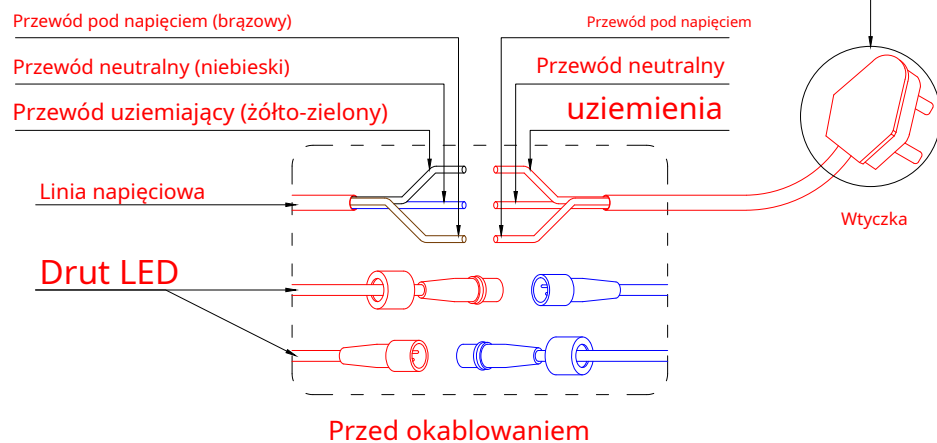

8

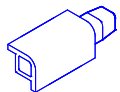

x 4

Zamocuj przedłużenie narożnika słupka

1) Jak pokazano, wsuń przedłużenie narożnika słupka w górną część narożnika słupka.

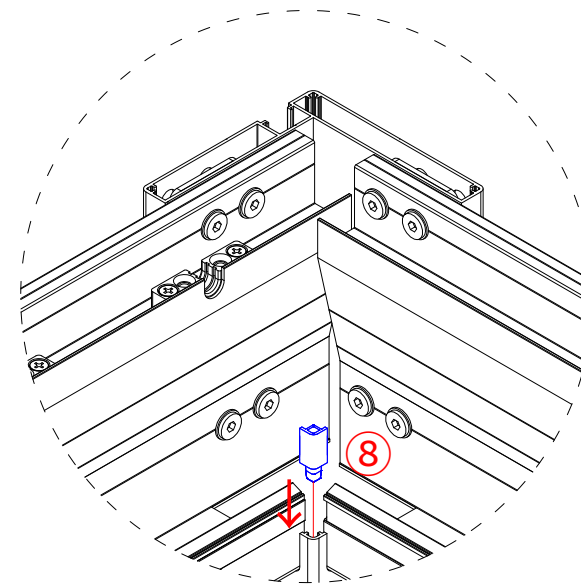
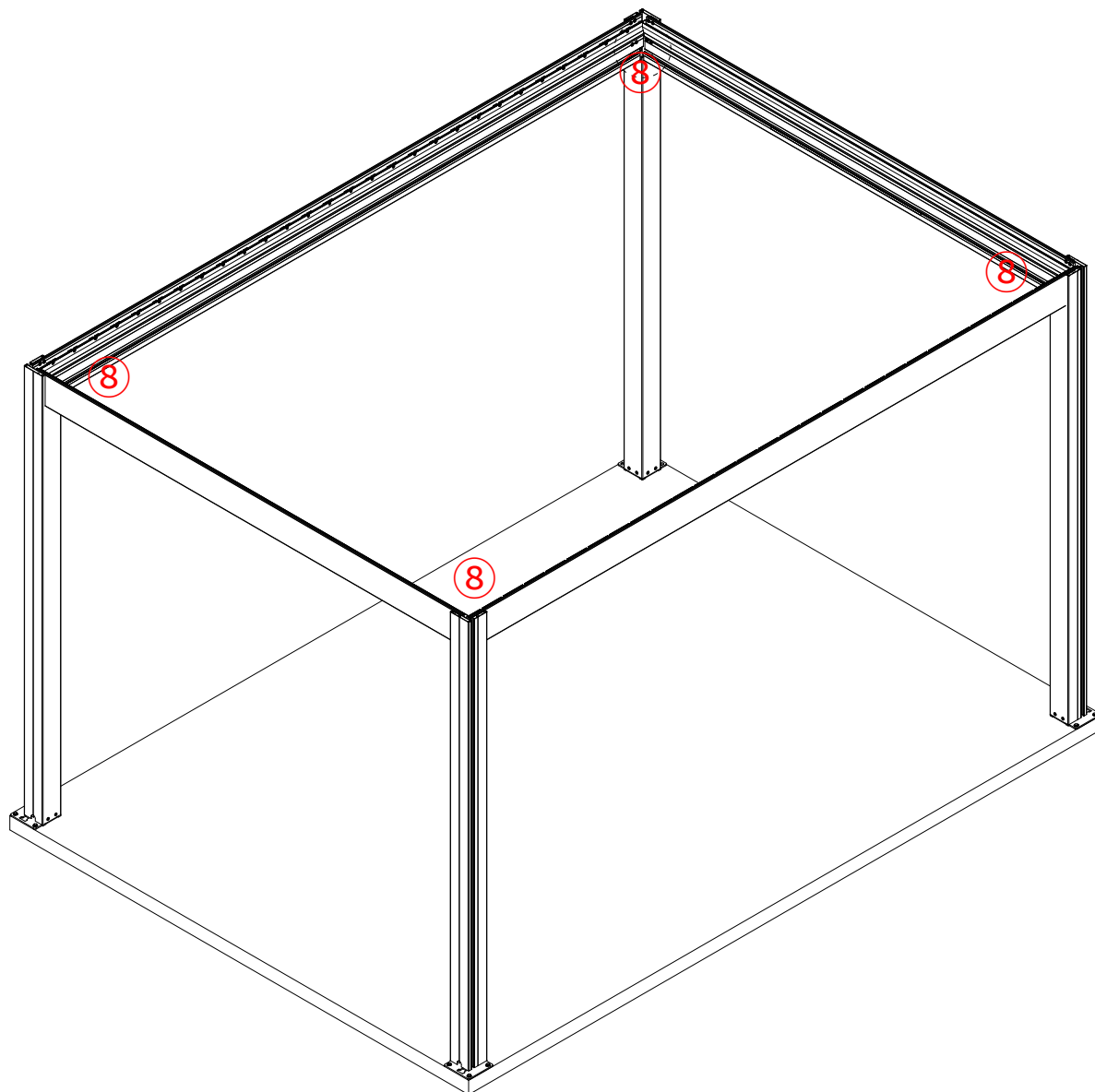

Krok 1

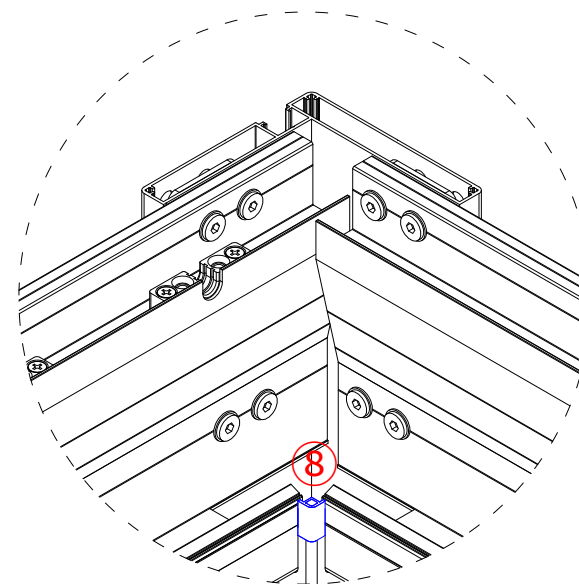

Krok 2

C-1**x 1**

Instalacja Luwru

- 1) Jak pokazano, żaluzja łącząca silnik C-1 zatrzaskuje się bezpośrednio w rowku.
- 2) Podłącz wspornik ramienia silnika do zaślęпки końcowej żaluzji łączącej silnik C-1.

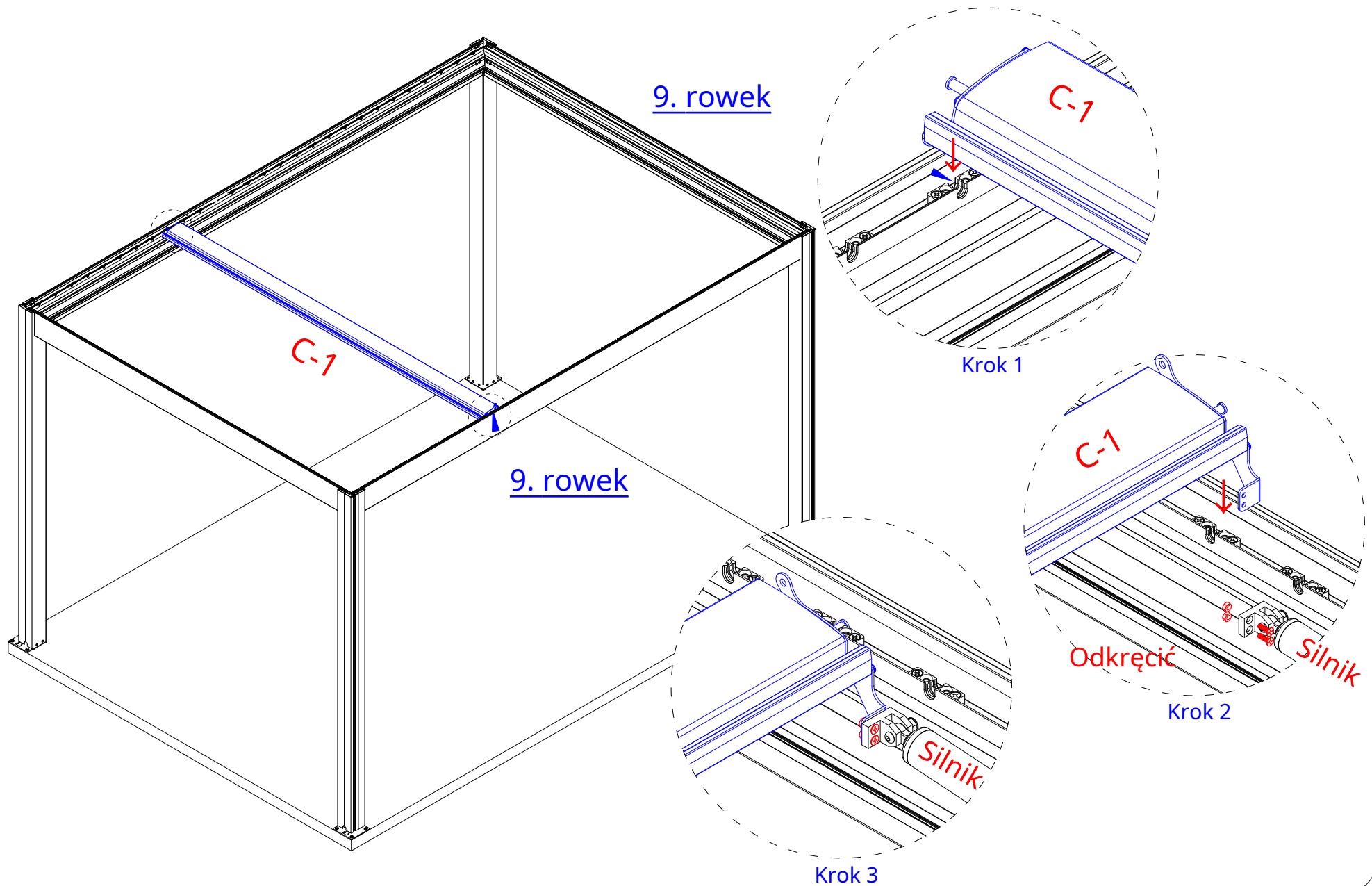

C-2



x27

Instalacja Luwru

3) Jak pokazano, żaluzja C-2 zatrzaskuje się bezpośrednio w rowku.

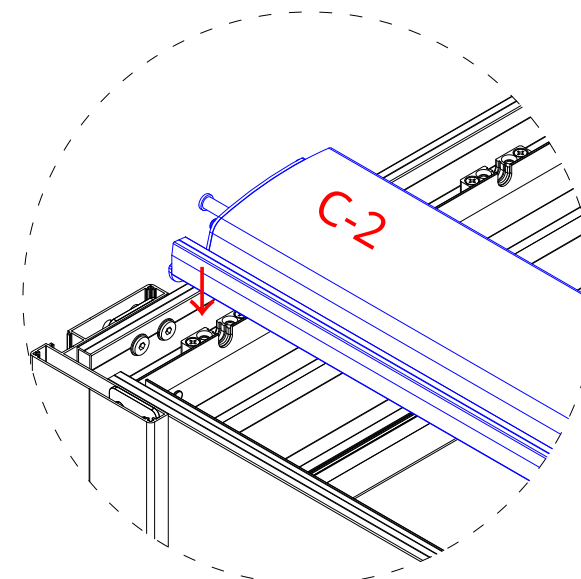
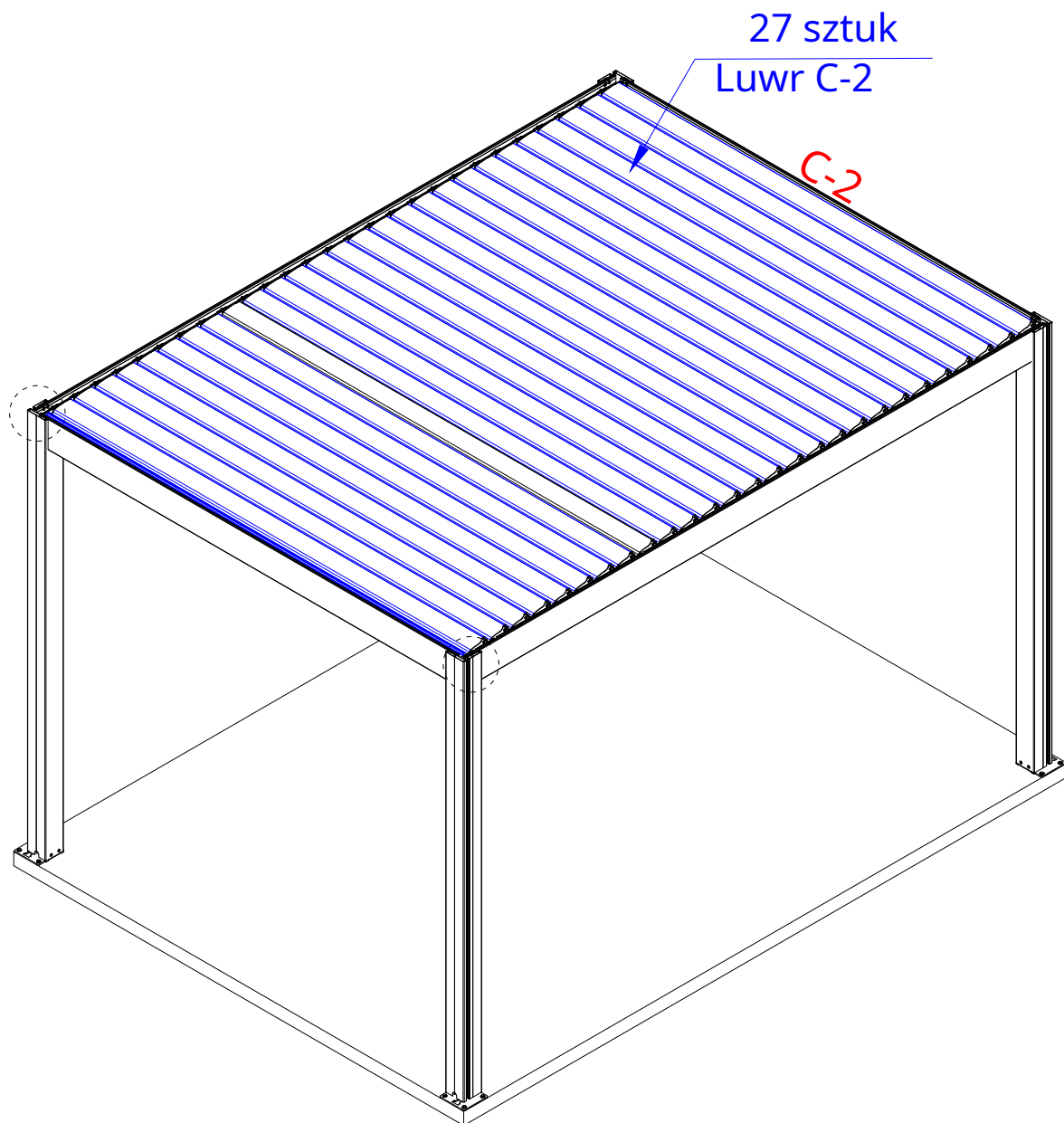

Krok 1

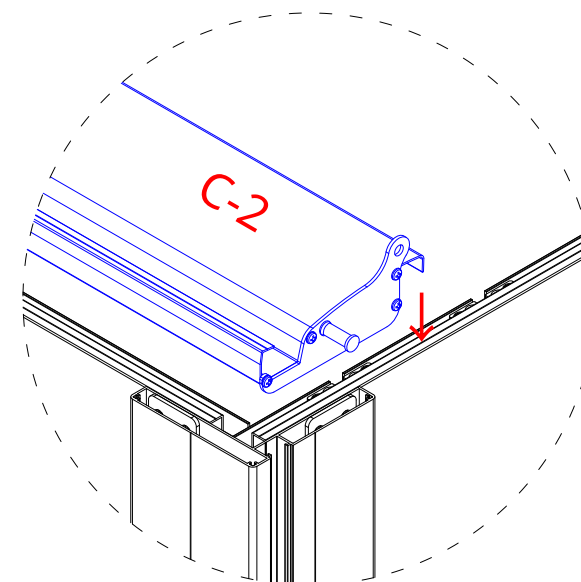

Krok 2

9

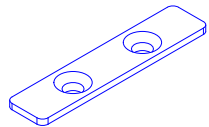

x56

10



x 112

Instalacja Luwru

4) Jak pokazano, zamocowano nasadkę uchwyty wału 9 włączając uchwyty wałuz Śruba stożkowa M5*16 10.

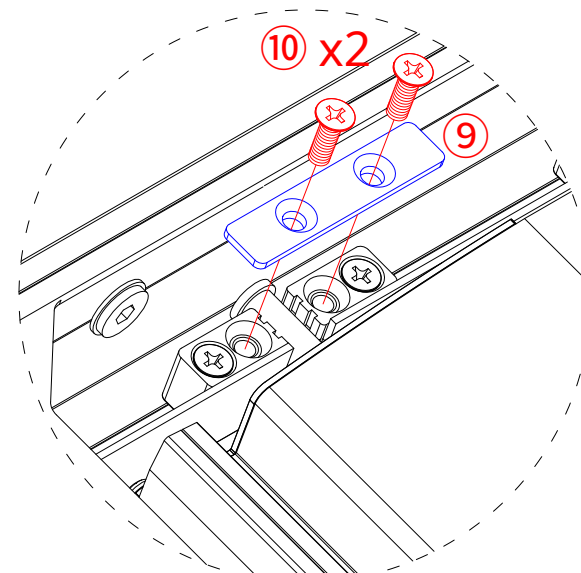
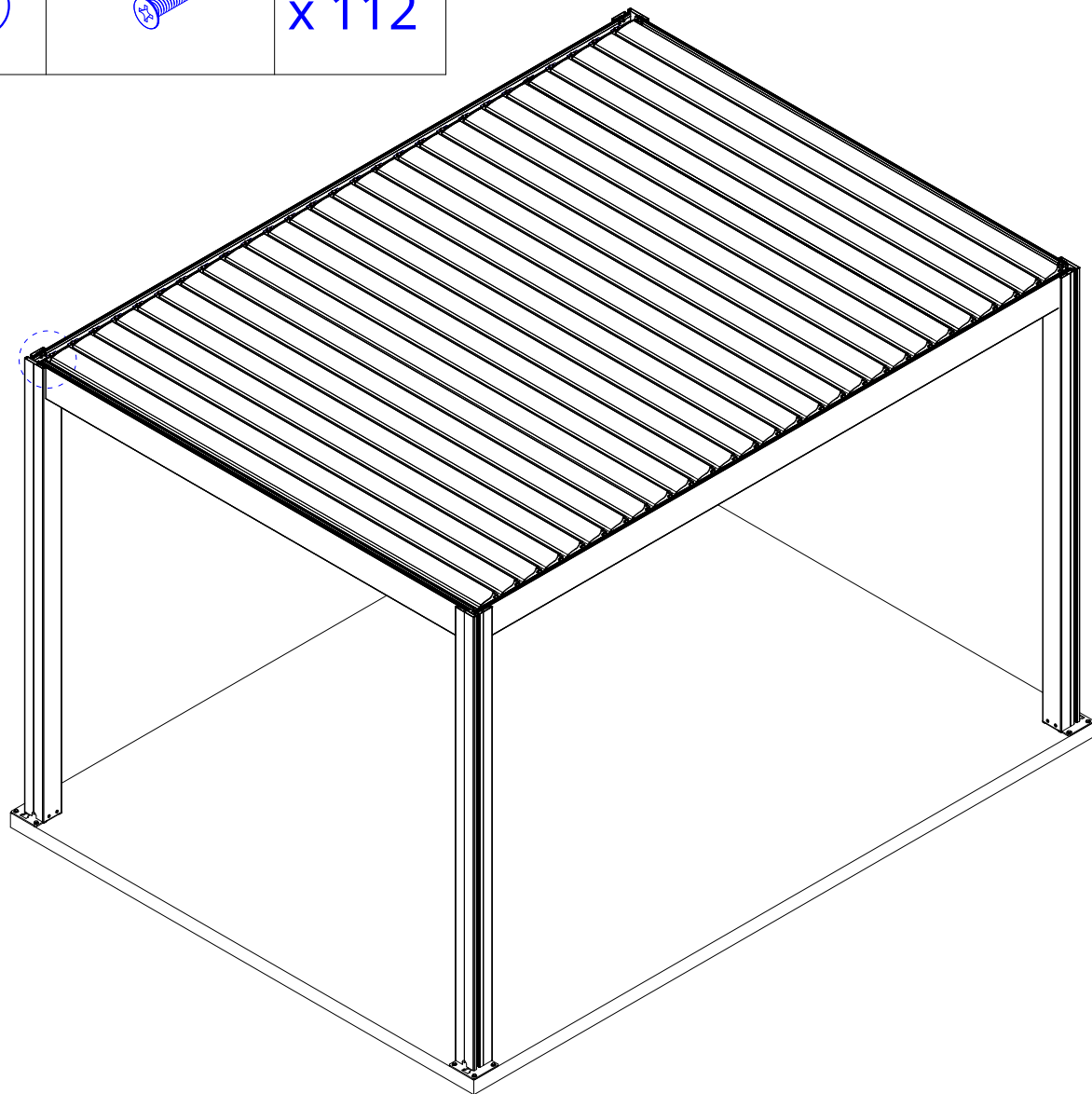

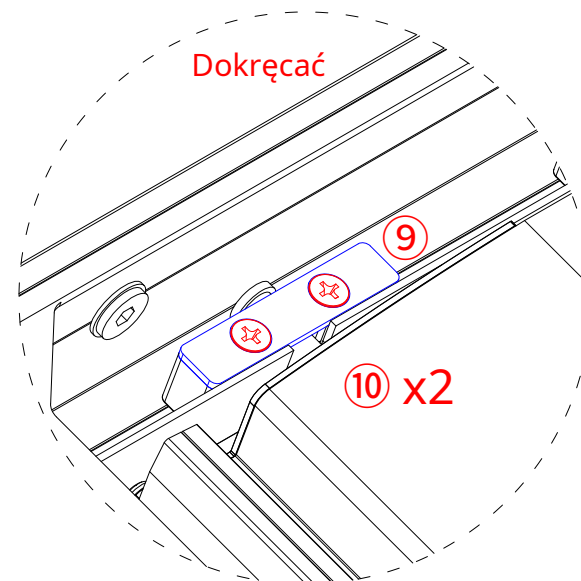

Krok 1



Krok 2

Dokręcać

D		X 1
11		x28

Instalacja Luwru

5) Jak pokazano, użyj śruby sześciokątnej M6*5¹¹ przez otwór (na dźwieszce regulacyjnym D), a następnie zamocować na żaluzji.

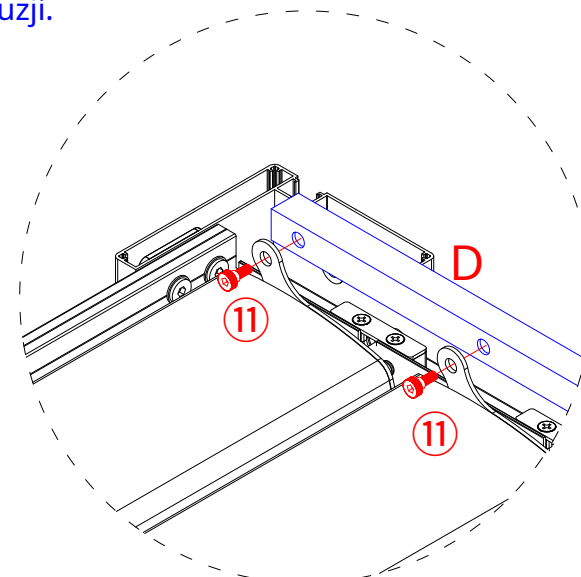
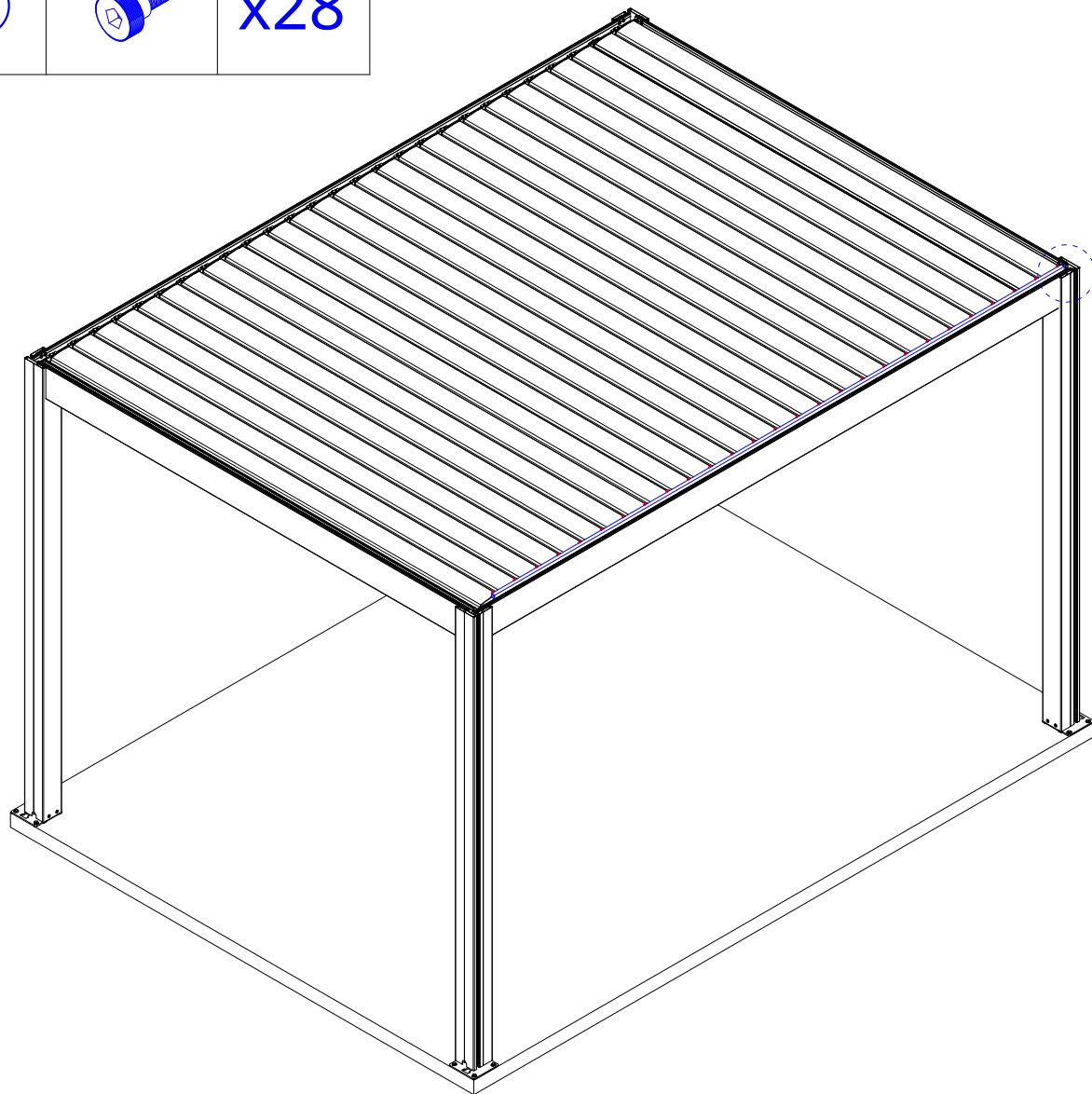

Krok 1

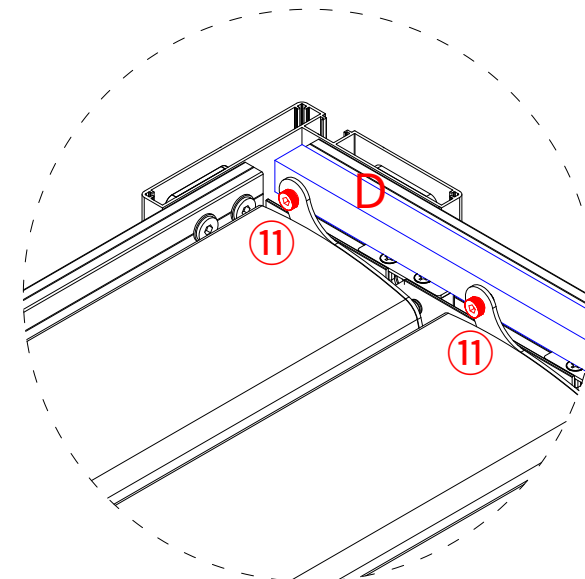

Krok 2

mi



x 4

Napraw pokrywę rowka T

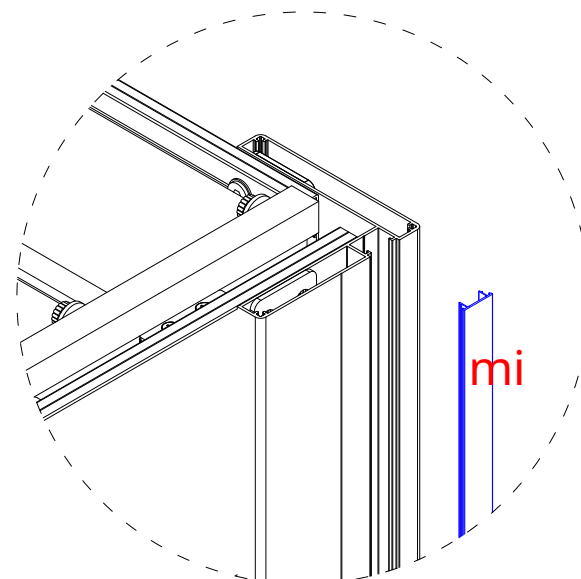
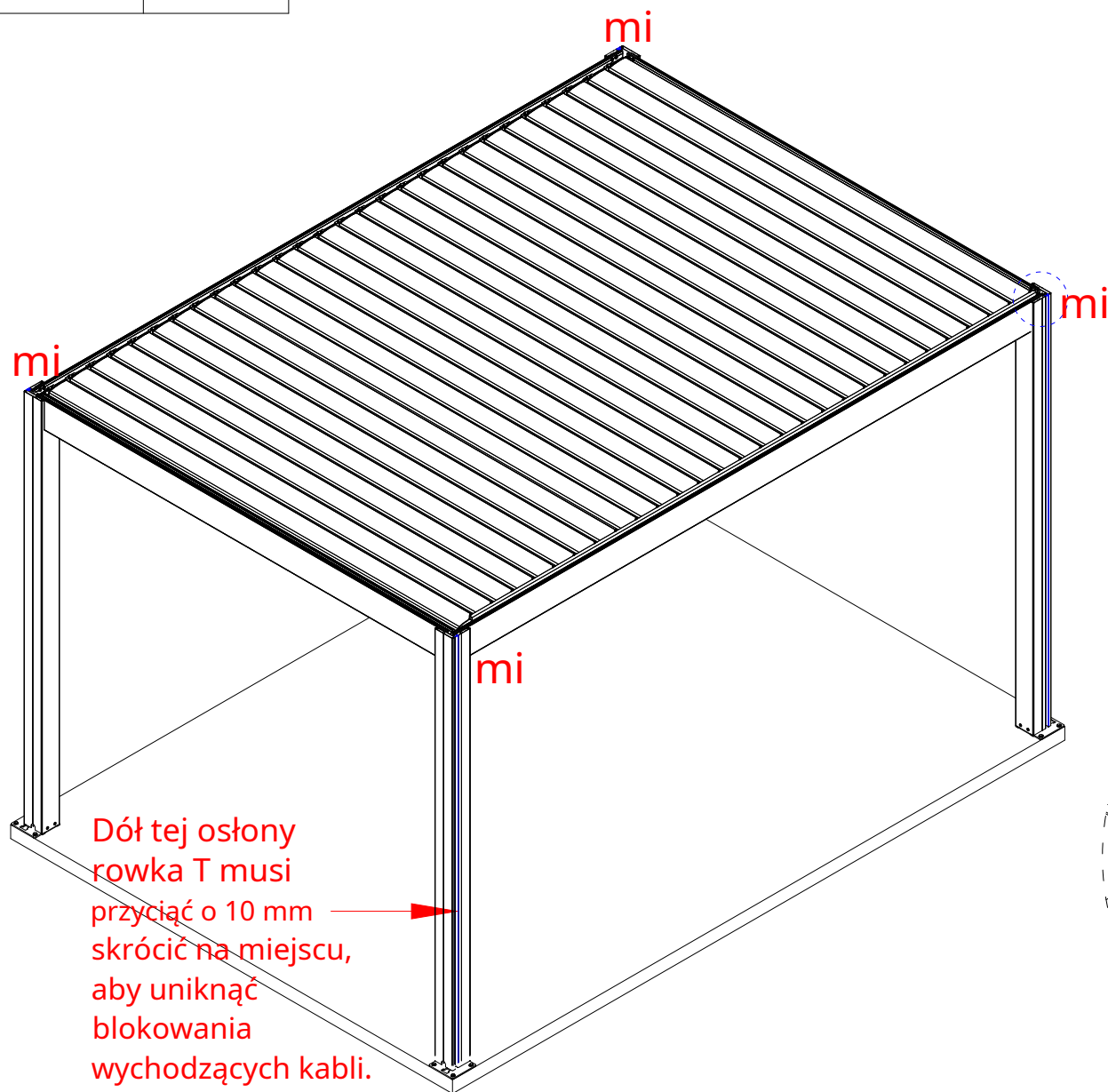

1) Jak pokazano, włóż osłonę rowka T E w rowek słupka.

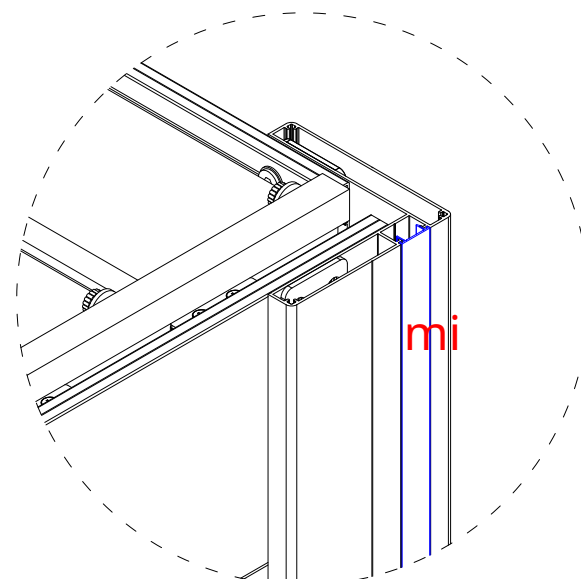

Krok 1

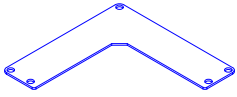

Krok 2

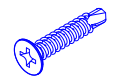
12		x 4
13		x 12
15		x 8

Zamocuj górną osłonę słupka

2) Jak pokazano, załóż zaślepkę w kształcie litery L¹² na górze słupka, a następnie przymocuj go za pomocą 3 wkrętów samogwintujących 4,2*16¹³ i 2 śruby z wiertłem 4,2*19¹⁵.

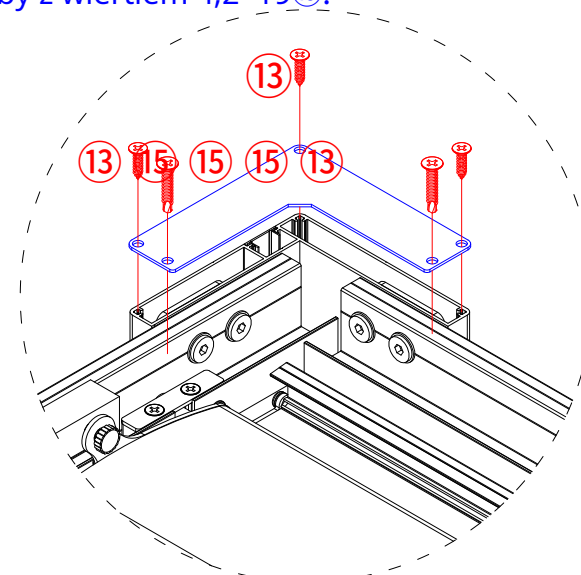
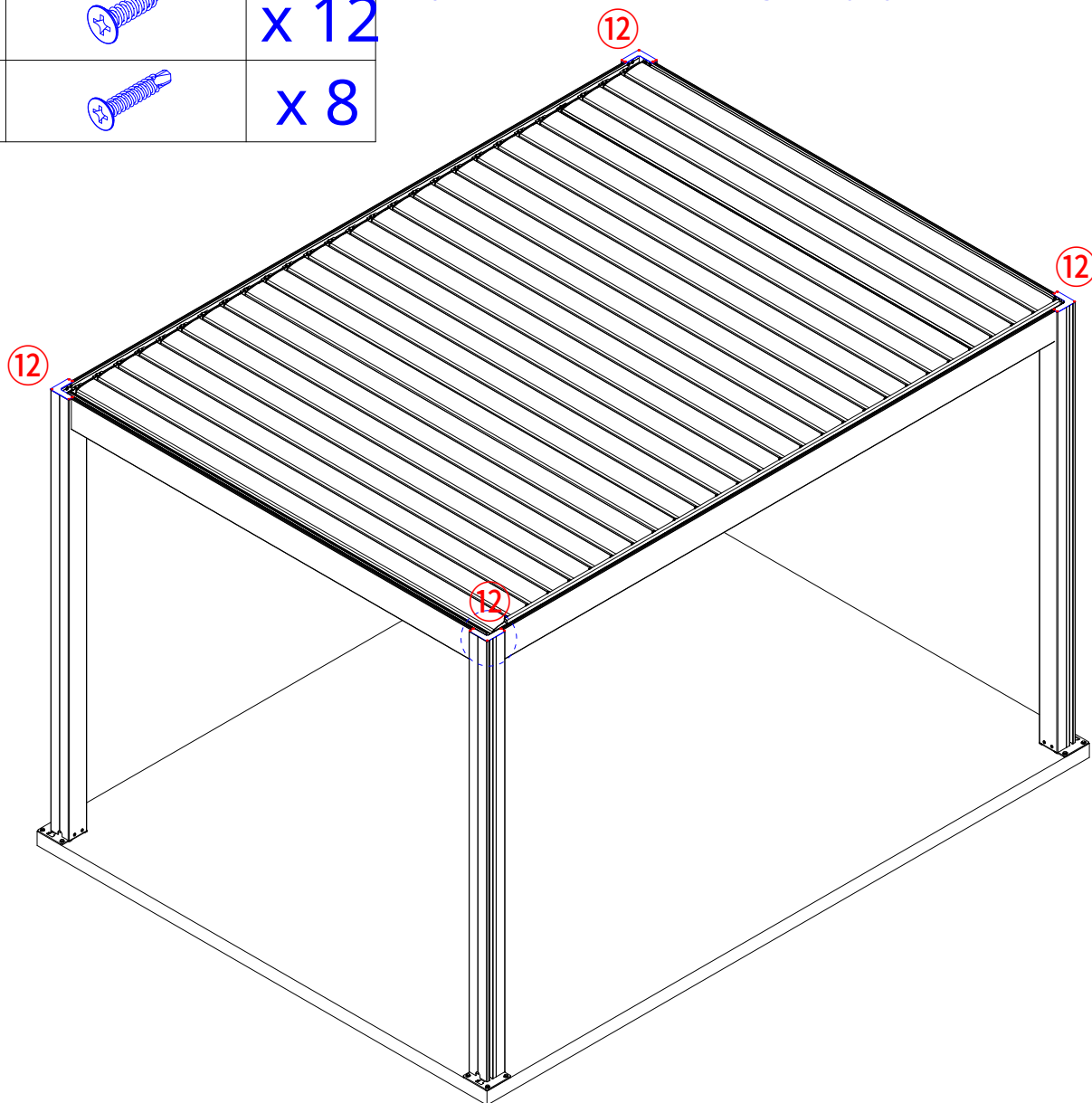

Krok 1

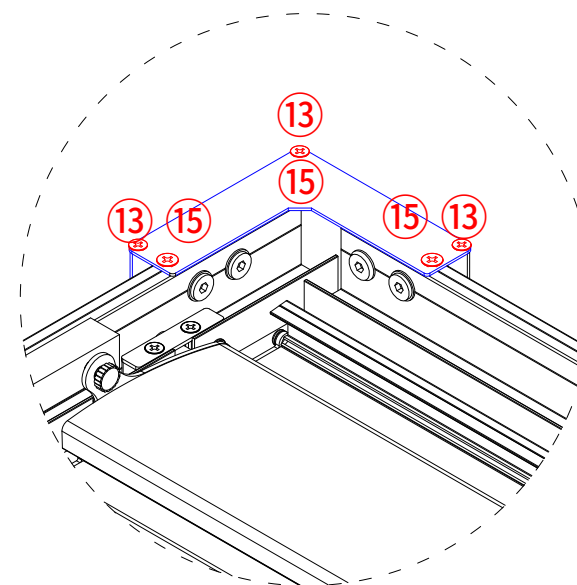

Krok 2

2

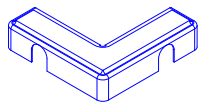

x 4

Instalowanie pokrywy płyty podstawy

1) Jak pokazano, wycięcie w kształcie litery U w pokrywie płyty podstawy powinno być skierowane w tym samym kierunku, co otwór odpływowy. Pokrywa płyty podstawy na słupku z dodatkowym wycięciem wylotowym.

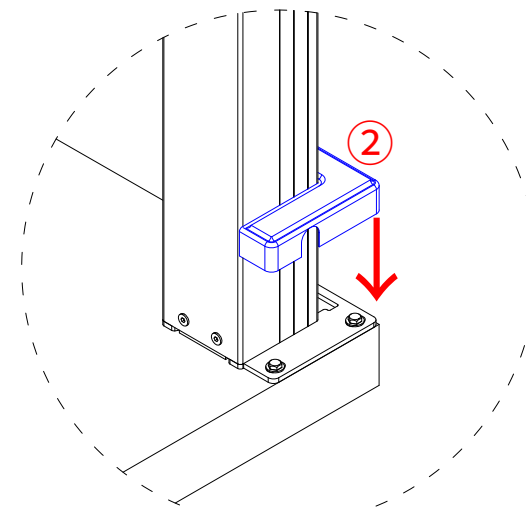
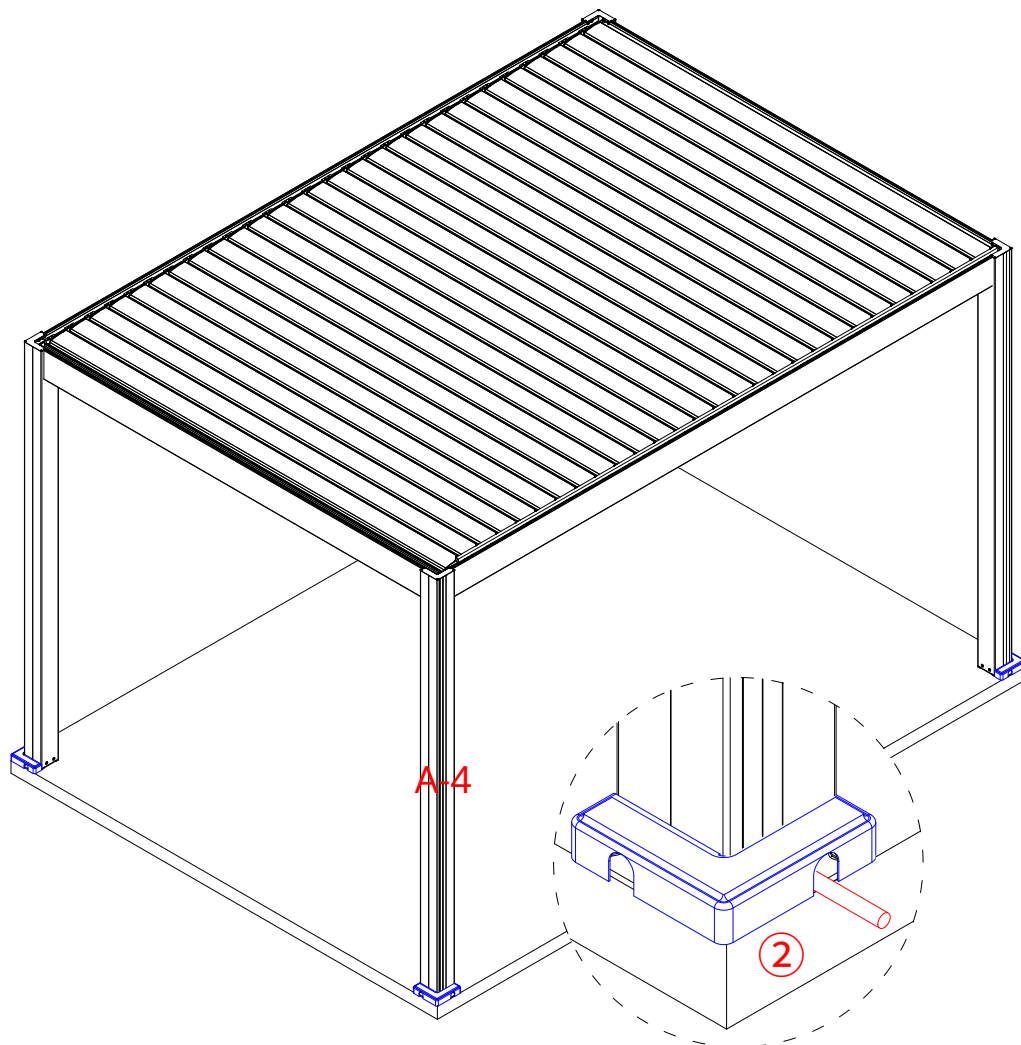

Krok 1

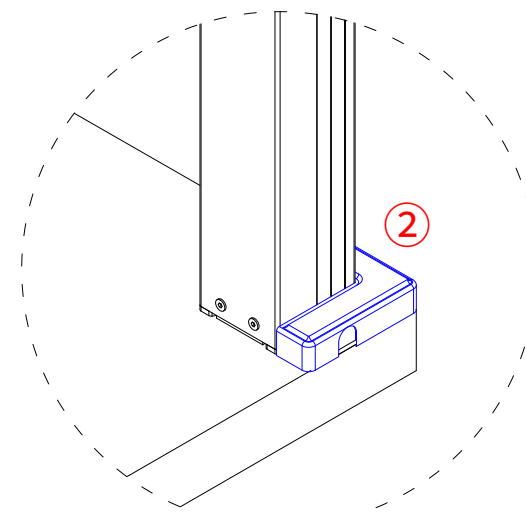

Krok 2

Jeśli pilot i odbiornik nie mogą sterować silnikiem, wykonaj poniższe czynności, aby ponownie zaprogramować.

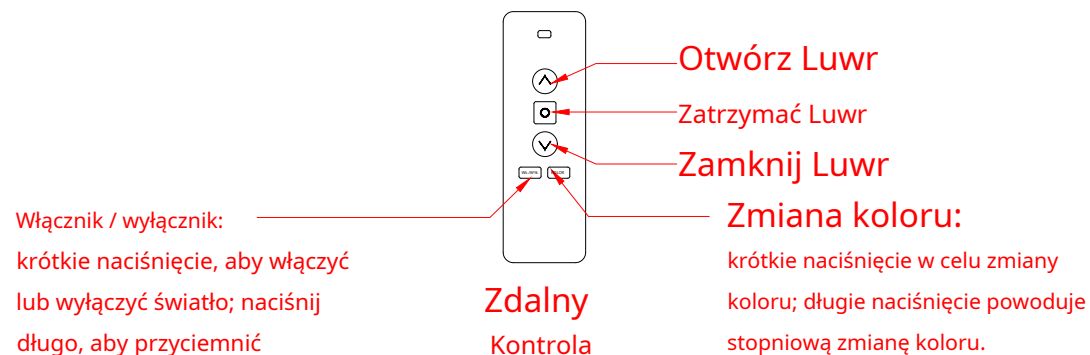

Kroki parowania:

1

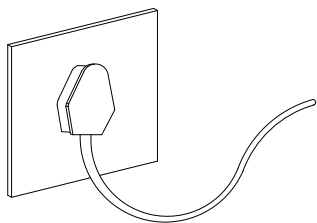

Wyłącz zasilanie na 15 sekund, a następnie podłącz je ponownie, a następnie proszę rozpocznij poniższe kroki w ciągu 30 sekund.

2



Otwórz tylną pokrywę pilota/odbiornika, naciśnij i przytrzymaj przycisk **Przycisk U2** przez ponad 7 sekund.

3

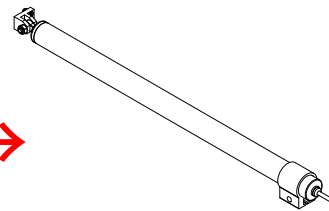

Kiedy silnik nadal robi A "bip, bip, bip" dźwięk.

4

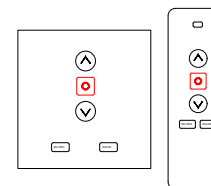

Naciśnij i przytrzymaj **przycisk stopu** pilota/odbiornika ponownie na dłużej niż 2 sekundy. Kiedy "bip, bip, bip" dźwięk silnika znika, oznacza to, że pilot/odbiornik został pomyślnie sparowany.

Kroki zmieniające kierunek:

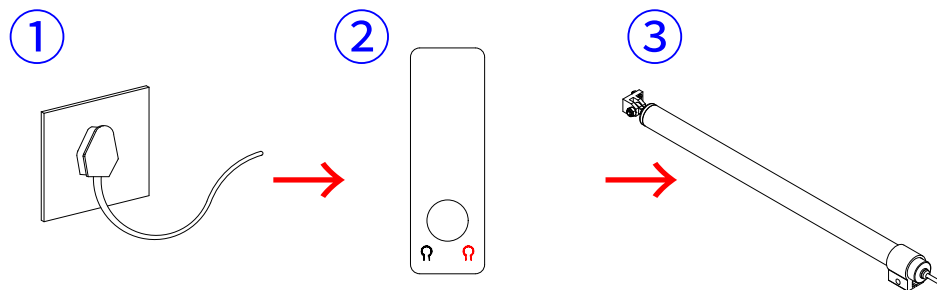

Wyłącz zasilanie na 15 sekund, a następnie podłącz je ponownie wtedy moc proszę rozpocząć następujące kroki w ciągu 30 sekund.

Otwórz tylną pokrywę pilota/odbiornika, naciśnij i przytrzymaj przycisk **Przycisk U2** przez ponad 7 sekund.

Kiedy silnik nadal robi A "bip, bip, bip" dźwięk.

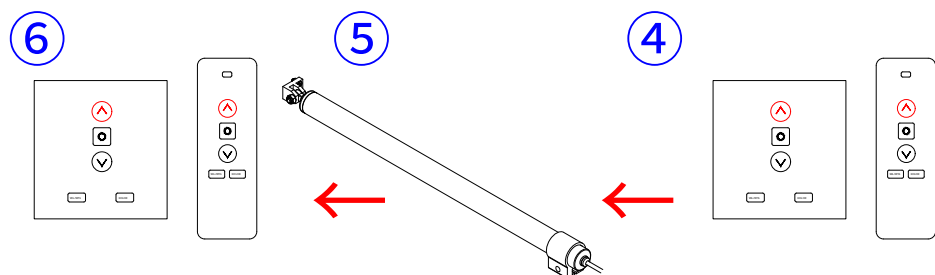

Naciśnij i przytrzymaj przycisk w górę pilota przez ponad 2 sekundy.

Silnik sprawia A "bip, bip, bip" "Znowu zabrmi"

Naciśnij i przytrzymaj przycisk w górę pilota/odbiornika dla ponad 2 sekundy.

Kroki usuwania parowania:

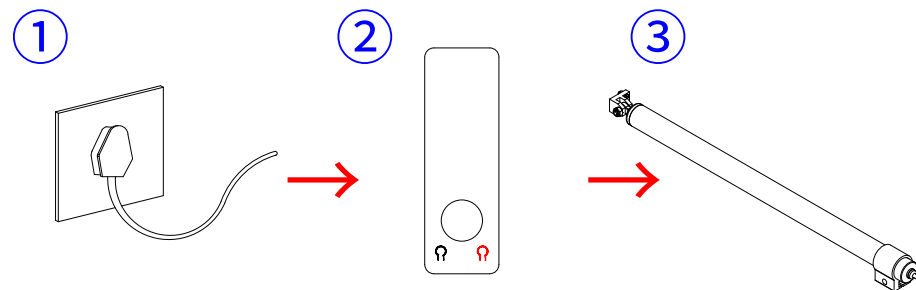

Wyłącz zasilanie na 15 sekund, a następnie podłącz je ponownie wtedy moc proszę rozpocząć następujące kroki w ciągu 30 sekund.

Otwórz tylną pokrywę pilota/odbiornika, naciśnij i przytrzymaj przycisk **Przycisk U2** przez ponad 7 sekund.

Kiedy silnik nadal robi A "bip, bip, bip" dźwięk.

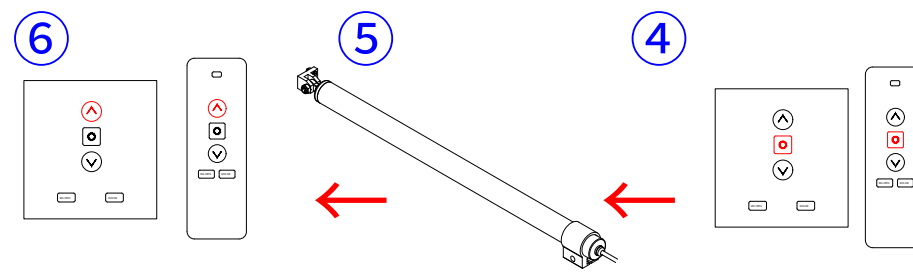

Naciśnij i przytrzymaj przycisk w górę pilota/odbiornika dla ponad 2 sekundy. Usuń parowanie z powodzeniem.

Silnik sprawia A "bip, bip, bip" "Znowu zabrmi"

Naciśnij i przytrzymaj przycisk stopu pilota/odbiornika dla ponad 2 sekundy.

Dbaj o swoją pergolę

Powierzchnie konstrukcji pokryte termoutwardzalnymi powłokami proszkowymi należy czyścić raz w roku, aby zachować swój pierwotny estetyczny wygląd.

Proszki termoutwardzalne są wrażliwe na:

- Tarcie fizyczne, mocne uderzenia, wytłaczanie, chemikalia, w tym rozpuszczalniki alkaliczne i rozpuszczalniki kwaśne.
- Elementy naturalne, takie jak wiatr, deszcz, śnieg i długotrwałe światło słoneczne. Zewnętrzna część pergoli może z czasem ulec zniszczeniu, co nie będzie objęte gwarancją.

Czyszczenie Twojej Pergoli

- Nie używaj czyścika, kremu do czyszczenia, szorstkiej gąbki, kulki z drutu żelaznego ani kolorowych ściereczek.
- Zalecane: Miękka gąbka, miękka szmatka niezawierająca piasku, wata, bawełna lub włóknina (tylko biała).
- Nie używaj produktów żrących, takich jak kwaśne lub zasadowe środki czyszczące. Zaleca się mycie wodą z detergentem o neutralnym pH, a następnie wycieranie szmatką w celu zapewnienia suchości.
- Podczas czyszczenia urządzeniami wysokociśnieniowymi należy zachować takie same środki ostrożności, jak podczas czyszczenia karoserii: należy wziąć pod uwagę odległość, rodzaj dyszy, temperaturę i ciśnienie wody.

Użyj Przypomnienia

- Po zakończeniu instalacji sprawdź, czy śruby są dokręcone. Pamiętaj, aby sprawdzać śruby przynajmniej raz w roku.
- **W przypadku przewidywanych opadów śniegu, gradu lub silnego wiatru o prędkości przekraczającej 80 km/h zaleca się otwarcie żaluzji. Nie uruchamiaj noży w przypadku mrozu lub śniegu. W przypadku obfitych opadów śniegu należy zdjąć ostrza z pergoli.**
- Regularnie sprawdzaj warunki uszczelnienia, aby upewnić się, że uszczelki lub inne elementy nie przeciekają.
- Regularnie czyść pergolę z zanieczyszczeń, takich jak opadłe liście, aby zapobiec zatykaniu odpływu.
- Ograniczenia w stosowaniu: Systemy wodoszczelne, choć skuteczne, nie są zaprojektowane w celu zapewnienia całkowitej wodoodporności. Ulewne deszcze i silny wiatr mogą uszkodzić pergolę. Wszelkie powstałe uszkodzenia nie będą objęte gwarancją.

MANUAL DO PROPRIETÁRIO

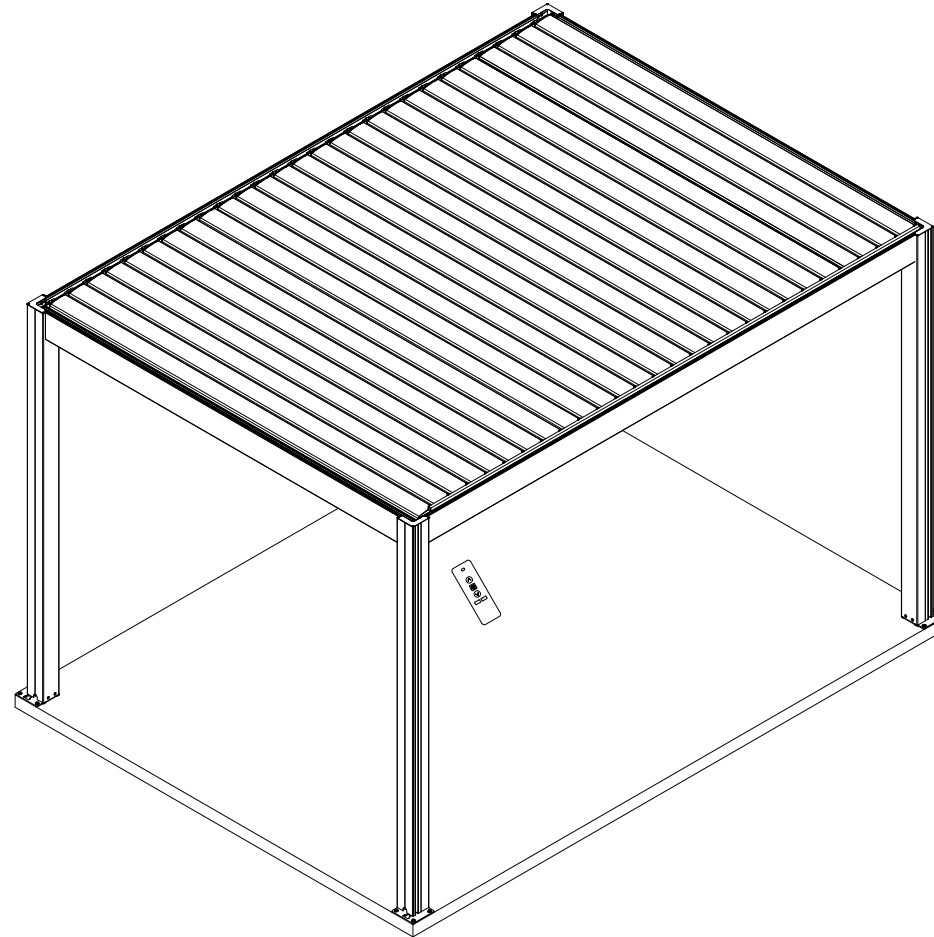

OTHER LANGUAGES

Pérgula 4 x2,86eu

Por favor leia este manual antes de usar a sua pérgula pela primeira vez.
Por favor guarde este manual para futura referência.

Pérgola

Abertura: Elétrico

Tamanho: 295,3(Comprimento) 409(Largura) -cm

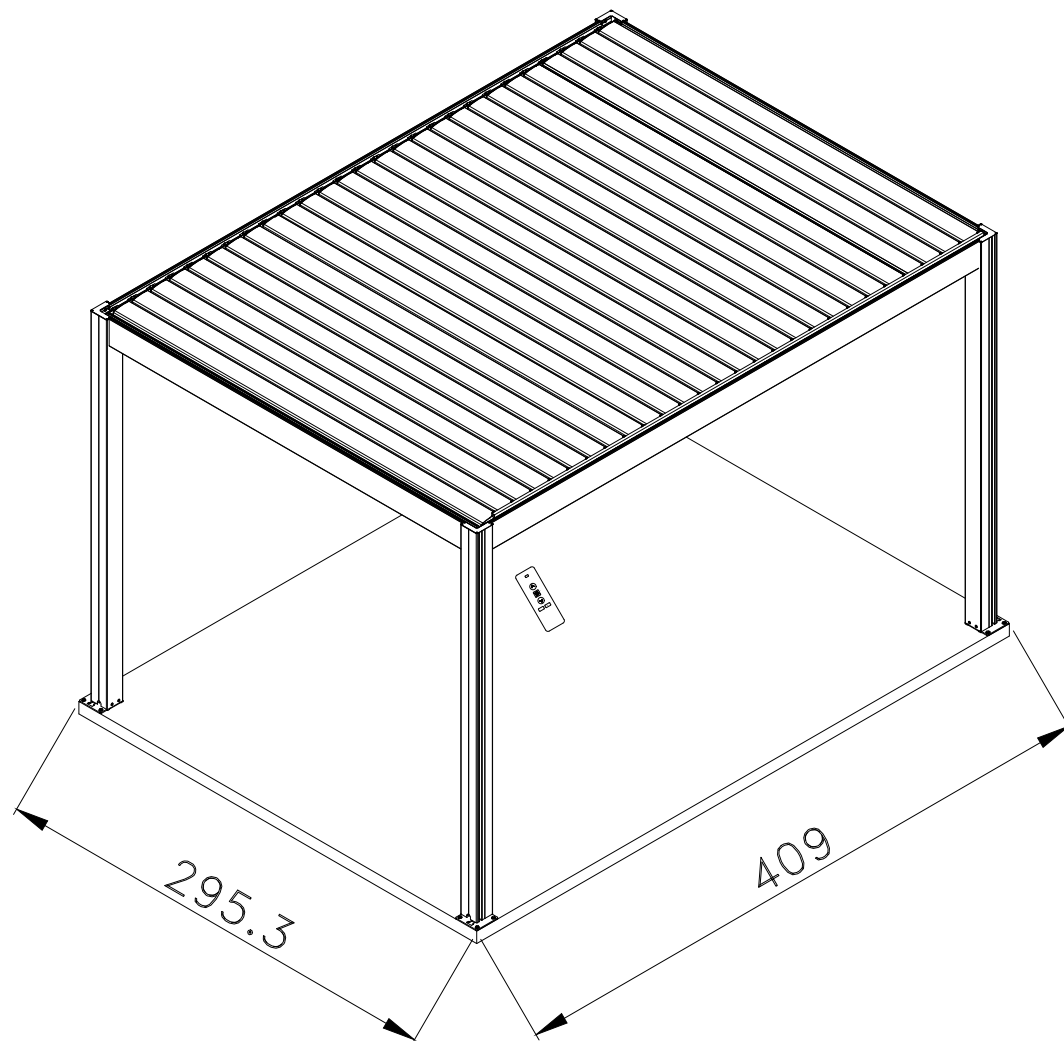

Notas de instalação:

1. A instalação requer um mínimo de três pessoas: uma para medição e marcação, uma para instalação e outra como assistente.
2. Somente fixadores para piso de concreto são fornecidos. No caso de não existir laje de concreto no terreno, recomenda-se a confecção de lajes de concreto em cada pilar. A laje de concreto deve ter no mínimo 500x500x500mm.
3. Após a montagem da moldura do Pergolado, utilize um esquadro, nível e régua para medir o nível e a diagonal do produto para garantir o tamanho do pergolado. As bases precisam estar exatamente niveladas, sem tolerância.
4. A pérgula precisa ser aparafusada ao chão. Não levamos nenhuma responsabilidade se as telhas quebrarem durante a perfuração dos parafusos.
5. São necessárias ferramentas elétricas: certifique-se de que funcionam corretamente e siga as instruções de segurança.
6. Tenha cuidado ao usar ferramentas afiadas.
7. Use roupas de proteção, incluindo óculos de segurança, capacetes e luvas.
8. Não suba nem fique no telhado.

Aviso de segurança

- . É altamente recomendável usar luvas para montagem.
- . Não instale a pérgula durante condições climáticas adversas, como vento ou chuva.
- . Não toque em nenhum fio com perfis de alumínio.
- . Sempre use sapatos e óculos de proteção ao instalar a pérgula.
- . Mantenha todos os sacos plásticos fora do alcance das crianças.
- . A coluna da pérgula deve ser posicionada e fixada em superfície plana.
- . Não se apoie na coluna durante a fase de montagem.
- . Não deixe que crianças se aproximem do local durante a fase de montagem.
- . Não fique perto da pérgula durante uma tempestade ou tufão.
- . Não tente subir na pérgula sob efeito de álcool ou drogas.
- . Ao usar escadas ou ferramentas similares e ferramentas elétricas durante a fase de montagem, siga as recomendações de segurança do fabricante.
- . Qualquer ferramenta quente, como uma furadeira elétrica, não pode entrar em contato com o perfil da pérgula.
- . Certifique-se de que não haja cabos ou outros cabos escondidos no subsolo antes de posicionar a coluna.

Conselho Geral

- . Esta pérgula possui vários componentes e leva pelo menos 90 minutos para ser montada. A pérgula não deve ser posicionada debaixo de uma árvore.
- . Se você conectar a coluna diretamente ao cimento ou base semelhante, use o furos pré-perfurados na base fornecida.
- . Verifique a quantidade de perfis e acessórios antes da montagem e utilize-os de acordo com a lista de acessórios de perfil para facilitar a montagem.
- . Coloque pequenos pedaços, como parafusos, em um recipiente para evitar perdas.
- . Preste atenção à posição da transmissão na viga para evitar posicionamento incorreto.
- . Limpe regularmente folhas, neve ou outros objetos da pérgula.

Manutenção e reparo

- . Para limpar a pérgula, use detergente neutro e enxágue com água. Não utilize acetona ou produtos de limpeza abrasivos para limpar a superfície do perfil de alumínio.

garantia

- . A garantia geral para descoloração é de 5 anos, para motor e iluminação LED 2 anos.

Ferramentas de proteção e instalação

Equipamentos de Proteção:

1. Capacete
2. Luvas
3. Kit de primeiros socorros de emergência
4. Óculos de proteção



Instrumento de medição:

1. Fita métrica (5 metros ou mais)
2. Régua quadrada
3. Nível

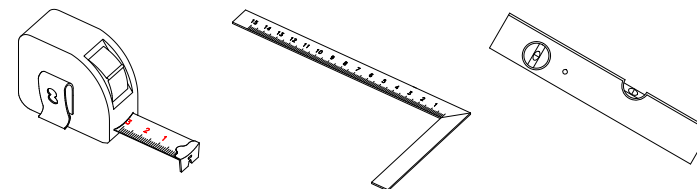



Ferramentas:

1. Escada de 2 metros (1,5 metros ou mais)
2. Chave sextavada de 13 mm
3. Chave sextavada de 17 mm
4. Furadeira elétrica
5. Broca elétrica (broca de 10 mm)
6. Marcador ou lápis
7. Martelo de borracha
8. Selante e pistola de cola





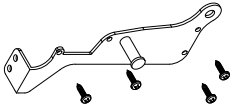
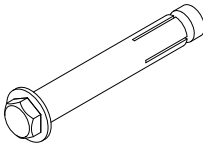
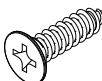
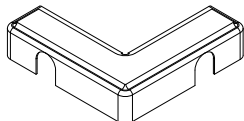
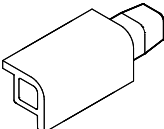
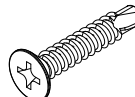
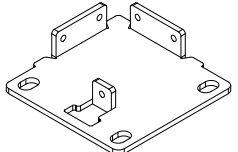
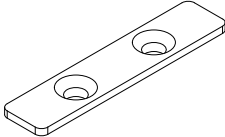
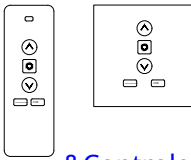
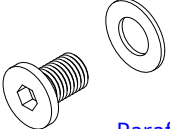

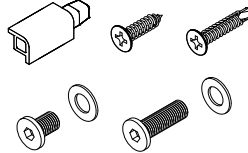
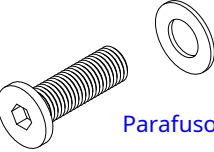
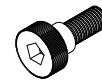
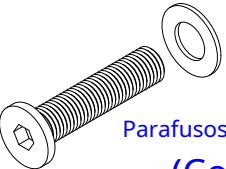
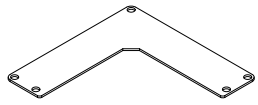

Silicon

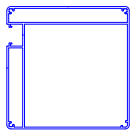
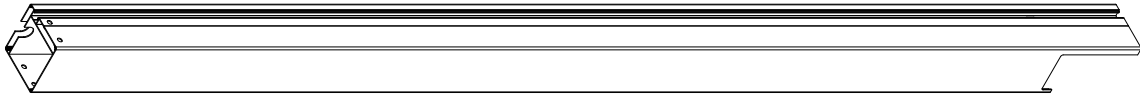
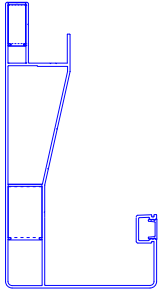
Lista de acessórios e parafusos

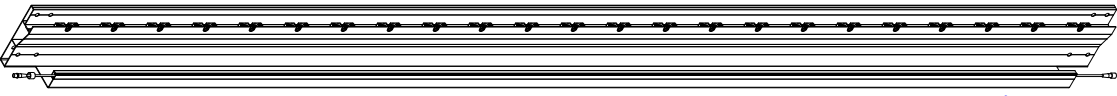
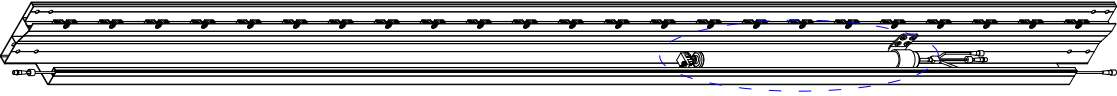
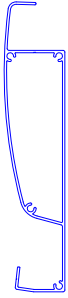
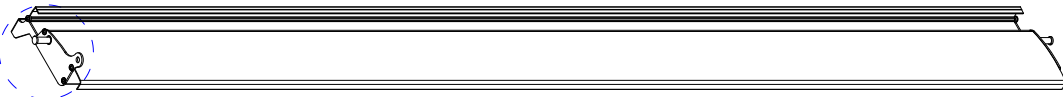
<p>①</p>	 <p>x 1 Tampa final para Louvre de conexão do motor e parafusos de cabeça plana 4*20</p>	<p>⑦</p>	 <p>x 16 Parafuso de expansão M8*80</p>	<p>⑬</p>	 <p>x 12 Parafuso 4.2*16 de cabeça chata</p>
<p>②</p>	 <p>x 4 Cobertura da placa base</p>	<p>⑧</p>	 <p>x 4 Pós Canto Peça de extensão</p>	<p>⑭</p>	 <p>x 8 Parafuso de perfuração 4.2*19</p>
<p>③</p>	 <p>x 4 Placa Base</p>	<p>⑨</p>	 <p>x 56 Tampa do suporte do eixo</p>	<p>⑮</p>	 <p>x 1 Receptor & Controle remoto de telhado</p>
<p>④</p>	 <p>x 16 Parafusos sextavados M8*12 (Com arruela)</p>	<p>⑩</p>	 <p>x 112 Parafuso escareado M5*16</p>	<p>⑯</p>	 <p>x 1 Peças de reposição</p>
<p>⑤</p>	 <p>x 16 Parafusos sextavados M8*25 (Com arruela)</p>	<p>⑪</p>	 <p>x 28 Parafuso sextavado M6*5</p>	<p>⑰</p>	
<p>⑥</p>	 <p>x 16 Parafusos sextavados M8*35 (Com arruela)</p>	<p>⑫</p>	 <p>x 4 Tampa superior do poste L</p>	<p>⑱</p>	

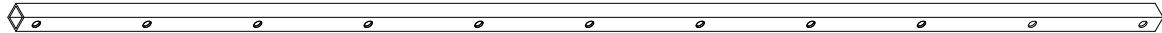
Lista de perfis

<p>A-1 ~ A-4</p>			<p>x 4 <small>Publicar</small></p>
<p>B-2 B-4</p>			<p>x 2 Viga e calha</p>
<p>B-1</p>			<p>x 1 Viga e calha (com suporte de eixo)</p>
<p>B-3</p>			<p>x 1 Viga e Calha (com suporte de eixo) + Motor</p>
<p>C-1</p>			<p>x 1 Louvre de conexão do motor</p>
<p>C-2</p>			<p>x 27 Louvre</p>
<p>D</p>			<p>x 1 Haste de controle</p>
<p>E</p>			<p>x 4 Tampa do slot T</p>

Desenho de layout de perfis de alumínio

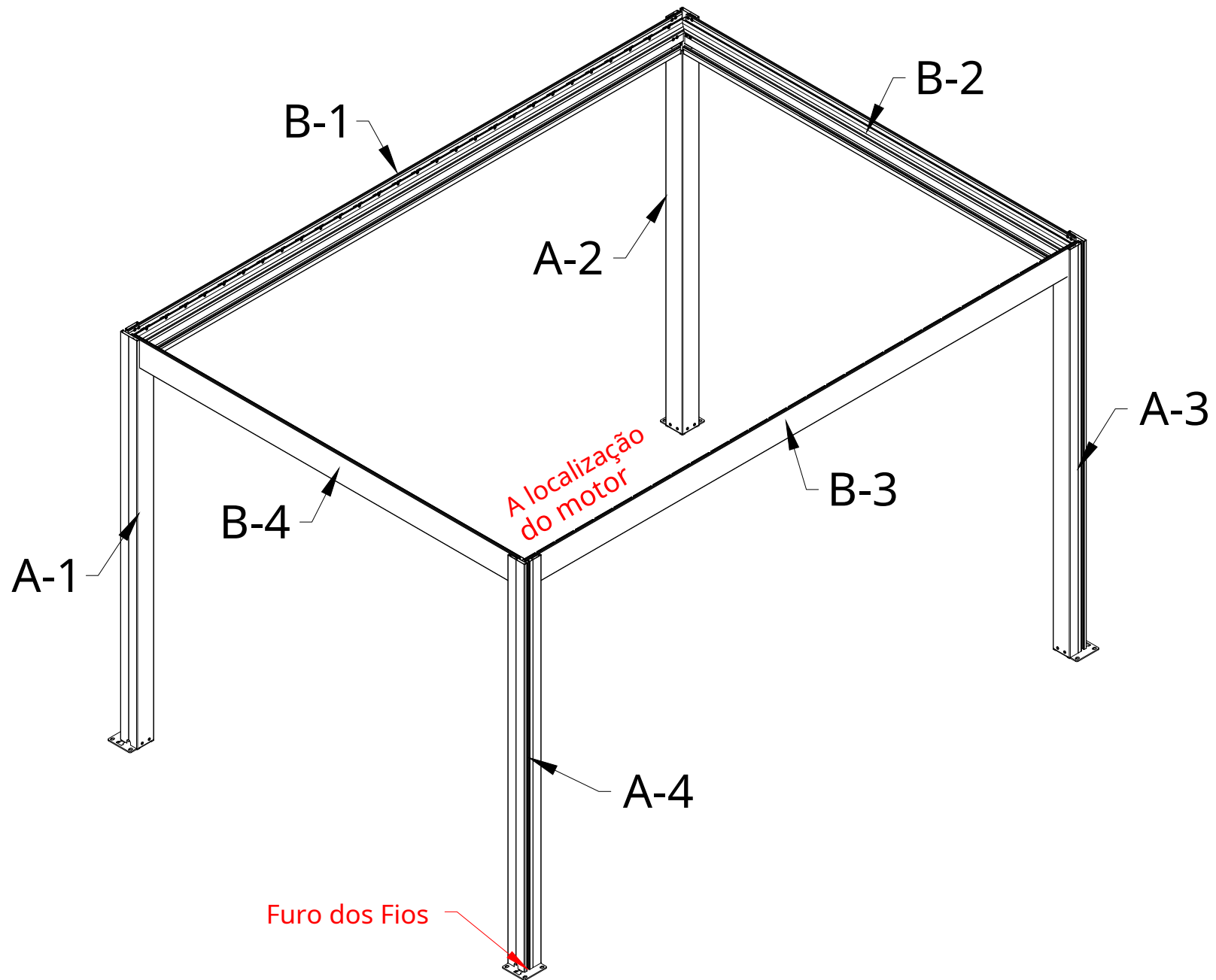

1

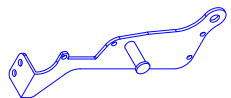

x 1



x 4

Instalando a grelha de conexão do motor

1) Fixou a tampa da lâmina na grelha de conexão do motor C-1 com parafusos de cabeça chata 4*20.

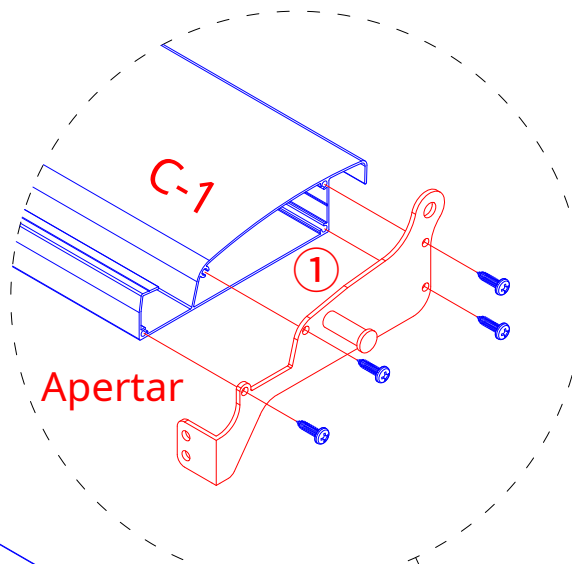

Passo 1



Se o local de instalação for apertado, as tampas das lâminas poderão ser instaladas após a instalação da estrutura.

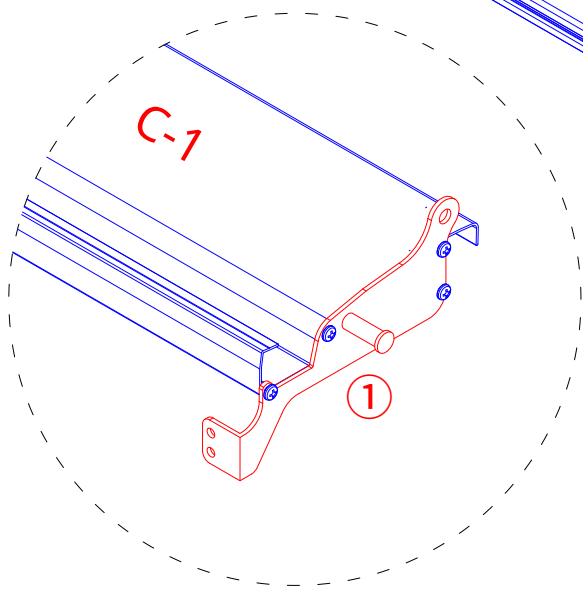

Passo 2

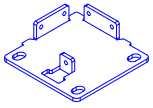
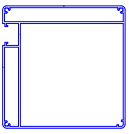
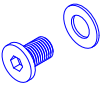
③		x 4	A-1 ~ A-4		x 4
④		x 16			

Monte a estrutura

- 1) Conforme mostrado, insira a tampa da placa base ② nas postagens, em seguida, alinhe os orifícios na placa de base ③ com os furos nos postes e trave a placa de base ③ aos postes com os parafusos sextavados M8 * 12 (com arruela) ④.

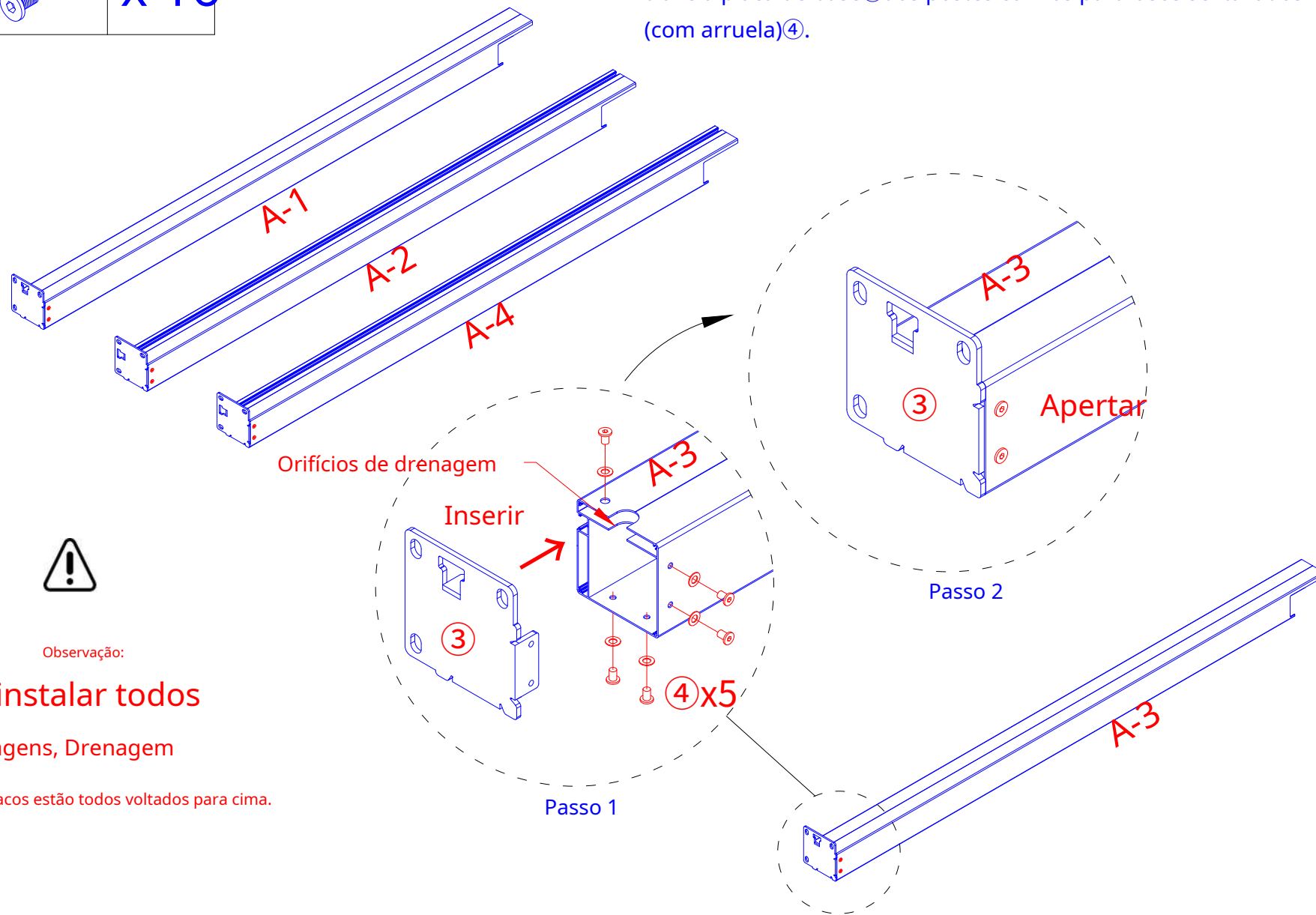

B-1 B-3		x 2
⑤		x 8
⑥		x 8

Monte a estrutura

2) Conforme mostrado, insira a viga e a calha (B-1, B-3) nas postagens, em seguida, conserte a viga e a calha (B-1, B-3) nos postes com parafusos sextavados M8*25⑤ e parafusos sextavados M8*35⑥.

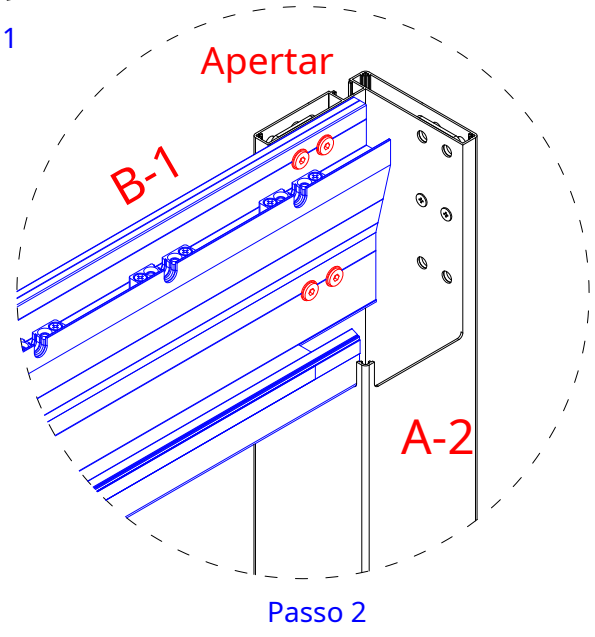
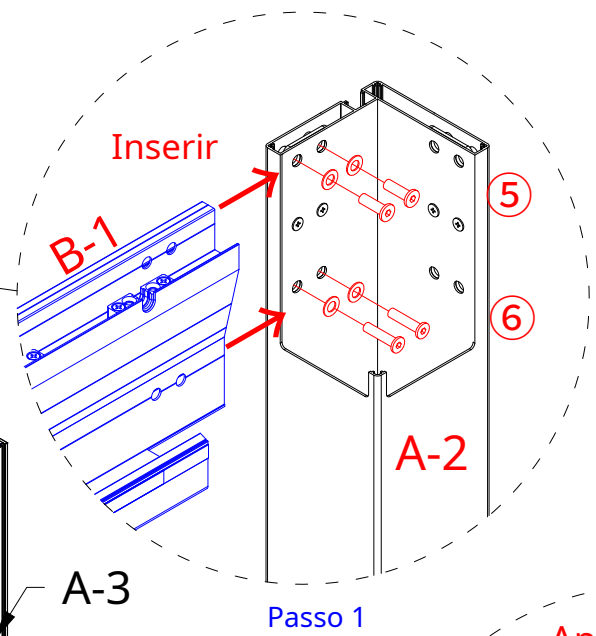
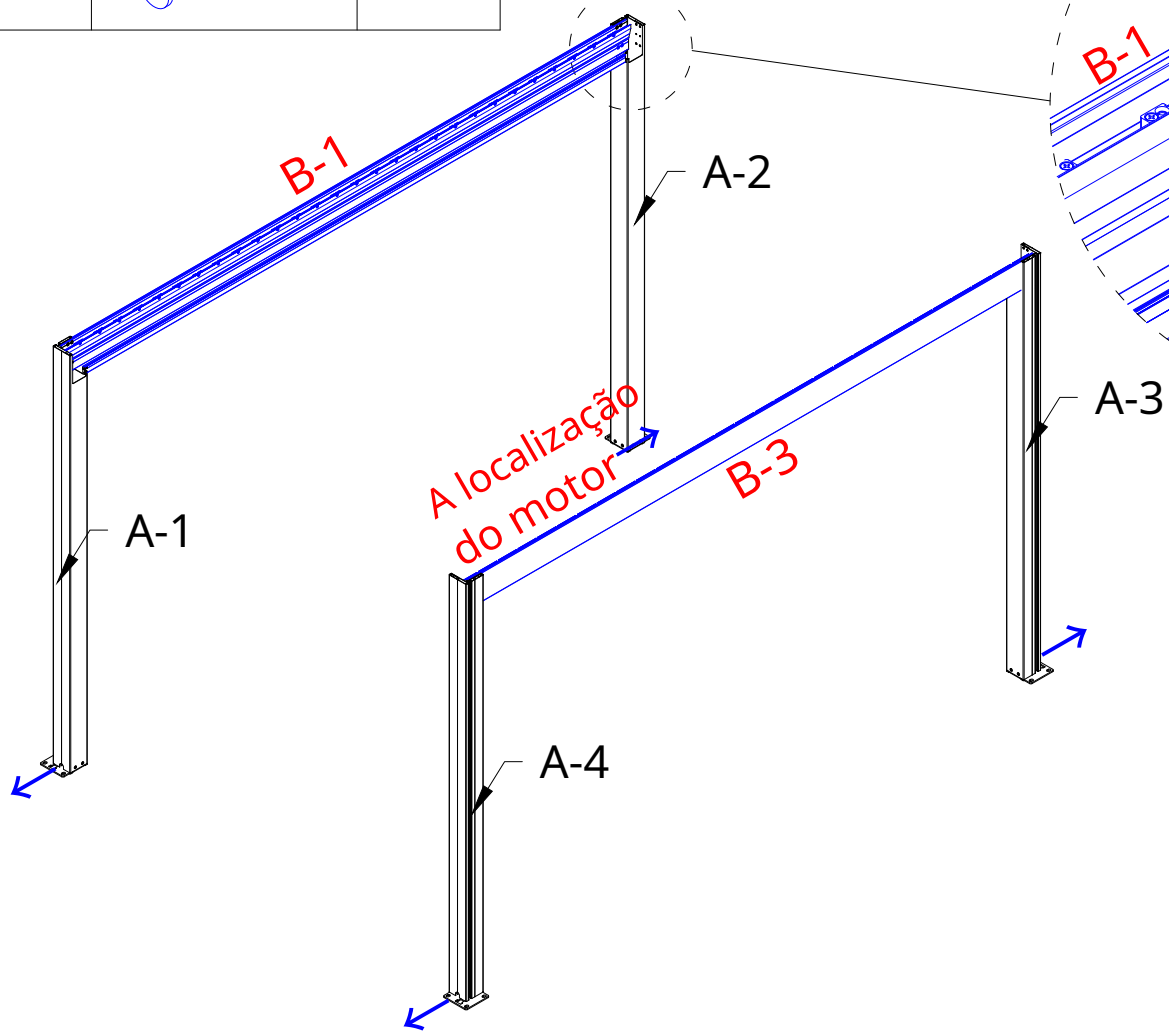

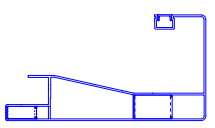
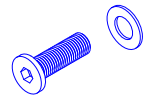
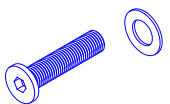
B-2 B-4		x 2
⑤		x 8
⑥		x 8

Monte a estrutura

3) Conforme mostrado, insira a viga e a calha B-2, B-4 nas postagens, então consertou o viga e calha B-2, B-4 nos postes com parafusos sextavados M8*25 ⑤ e parafusos sextavados M8*35 ⑥.

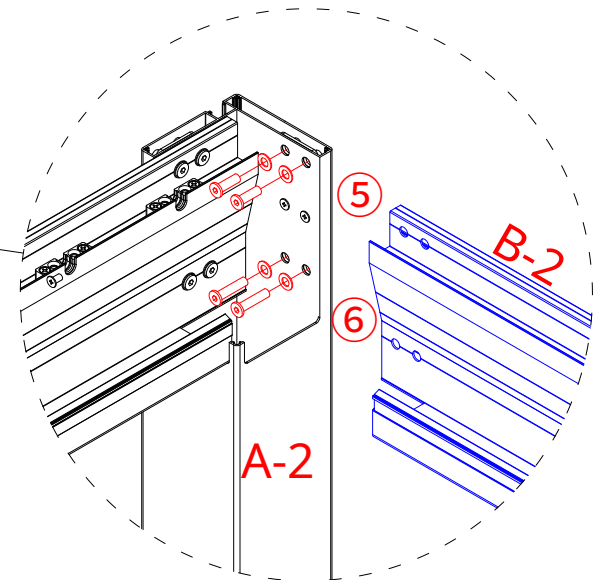
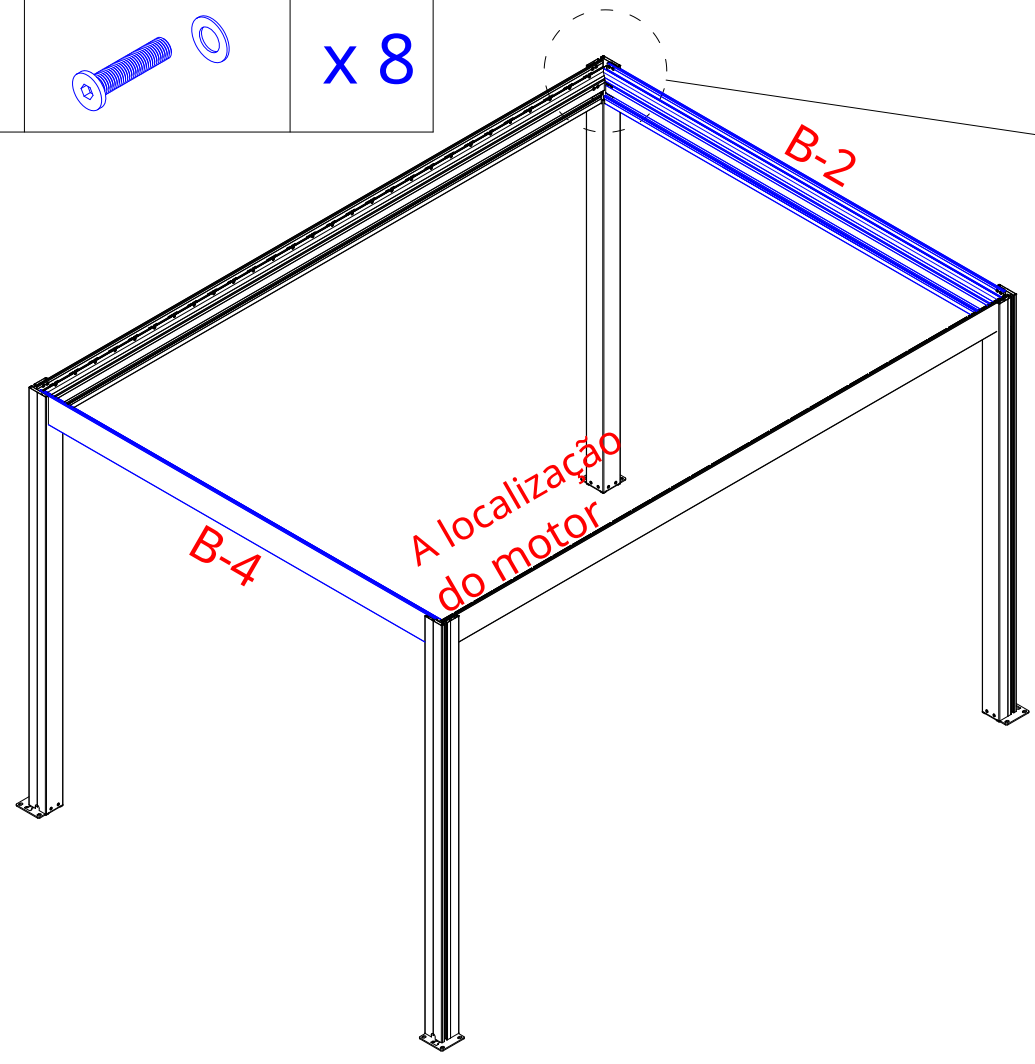

Passo 1

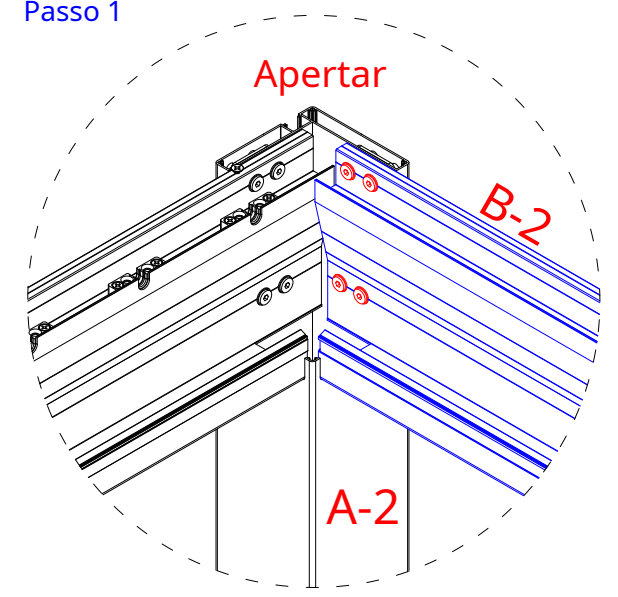

Passo 2

7

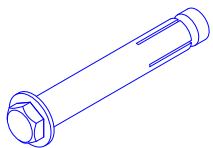

x 12

Observação:

Antes de fixar a placa de base, é necessário garantir que as diagonais dos 4 postes tenham o mesmo comprimento. Certifique-se de que o tamanho $W1=W2, W3=W4$.

Fixar a pérgula no chão

- 1) Use o parafuso de expansão 12 M8*80⑦ fornecido, se o solo for de concreto. Caso contrário, você precisará encontrar outra solução para aparafusar sua pérgula na superfície desejada.
- 2) Mova a pérgula para a posição de instalação apropriada, marque a posição dos quatro postes com o lápis, remova a pérgula e use a furadeira elétrica para fazer 12 furos de acordo com a marca. Mova a pérgula de volta para a posição e prenda a placa de base com o parafuso de expansão M8*80⑦.

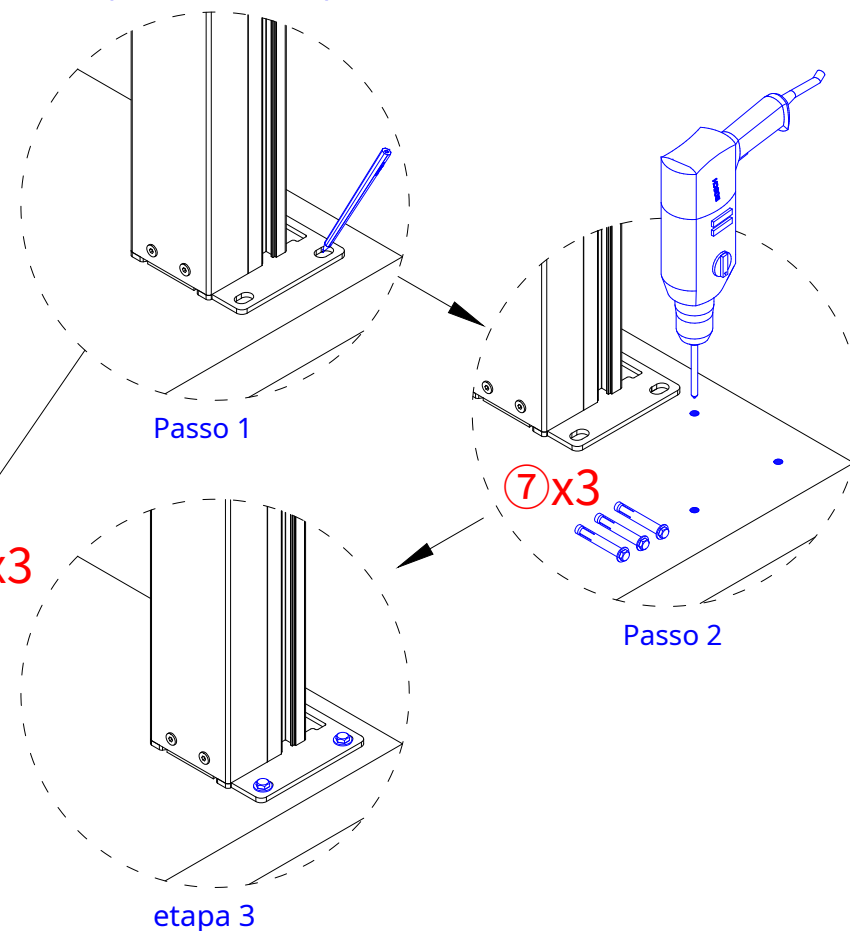
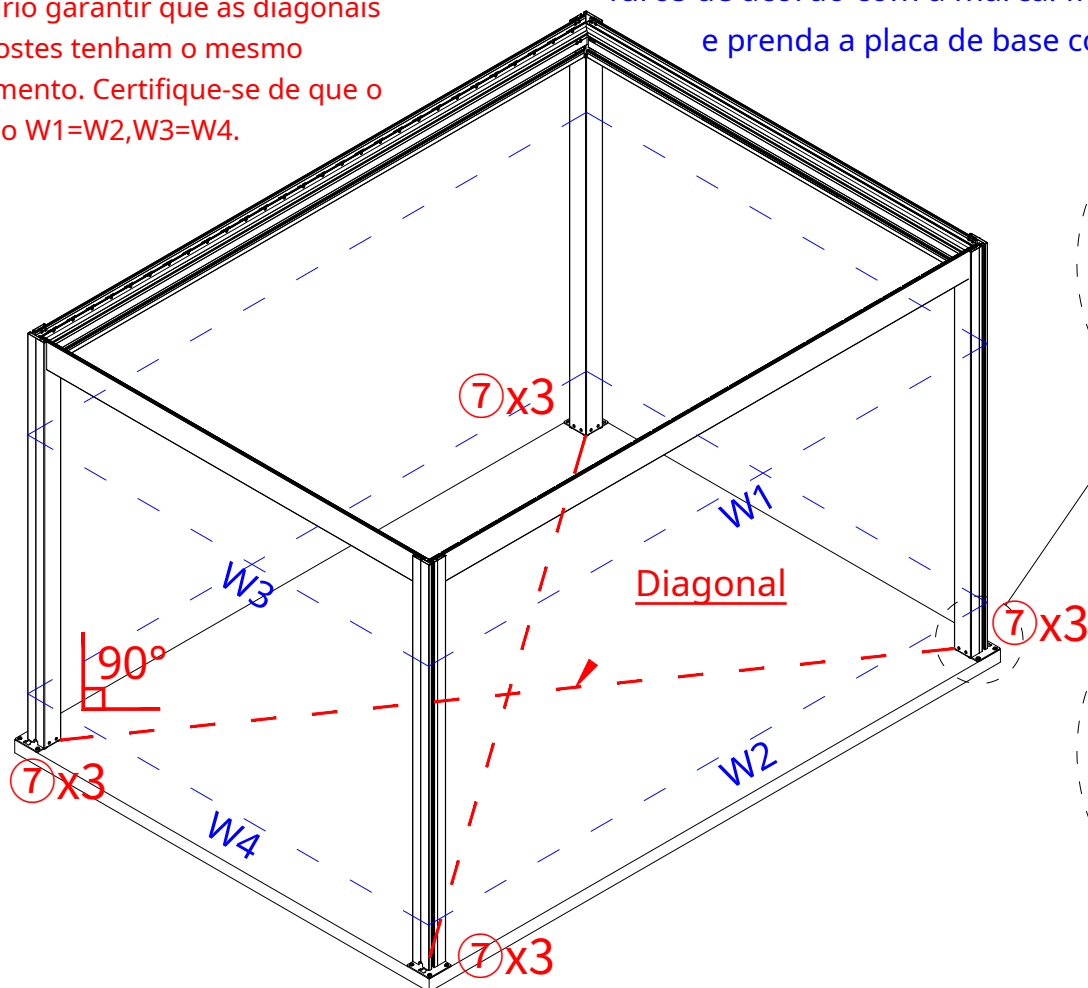

É da responsabilidade do utilizador garantir a fixação da pérgula. O fabricante não se responsabiliza por danos causados por desastres naturais ou eventos especiais na pérgula (ou nos seus acessórios). Qualquer pérgula que não for fixada poderá explodir e causar danos, e esta responsabilidade não será atribuída ao fabricante. Verifique regularmente a pérgula para garantir que permanece estável e firmemente fixada ao solo. Uma pérgula que se solte da sua posição e sofra ou cause danos não será coberta pela garantia.

 **Fio LED**

 **Fio de energia**

Passando os fios

Ao dispor os fios, deslize-os para dentro do poste a partir do entalhe na extremidade superior do poste, em seguida, puxe os fios até o orifício de saída, em seguida, puxe os fios para fora da tomada e, finalmente, saia do orifício na parte inferior do poste.

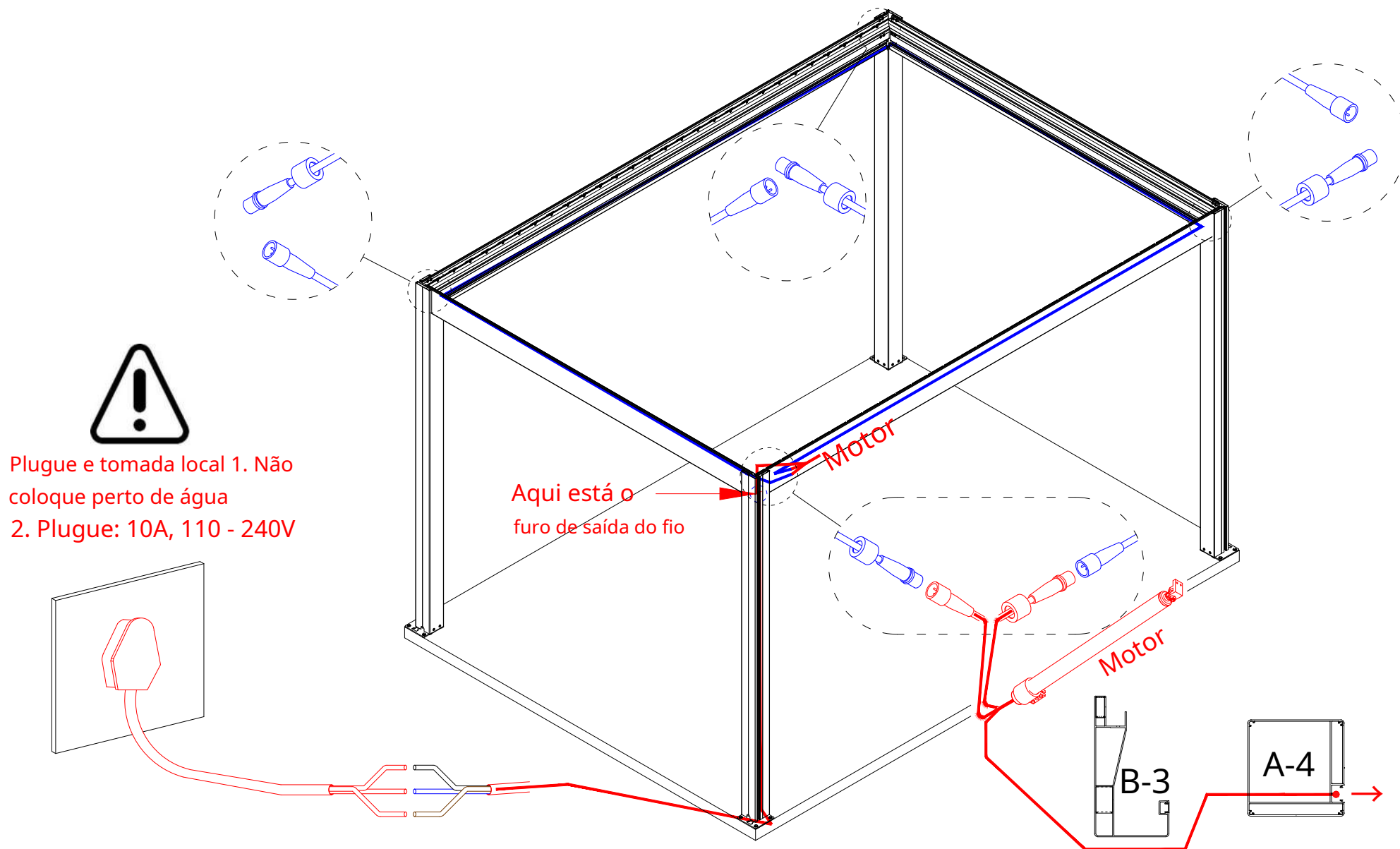



Nota: Siga as etapas para conectar o fio corretamente, caso contrário o motor apresentará defeito.



O plugue não é fornecido

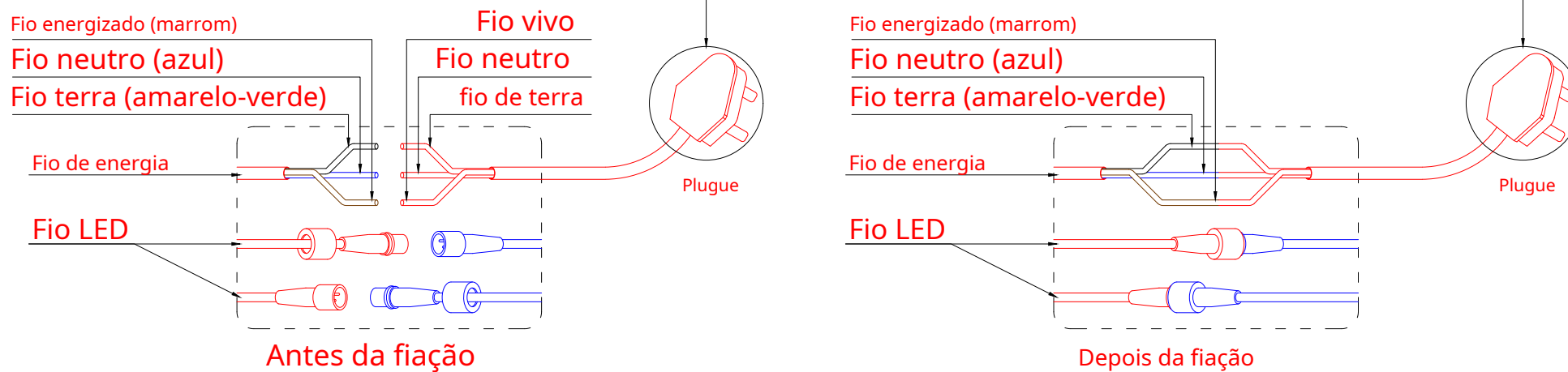

8

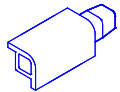

x 4

Fixe a peça de extensão do canto do poste

1) Conforme mostrado, deslize a peça de extensão do canto do poste na parte superior do canto do poste.

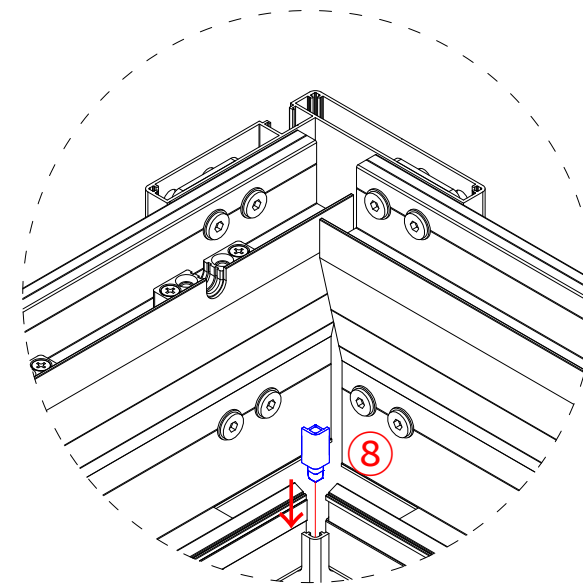
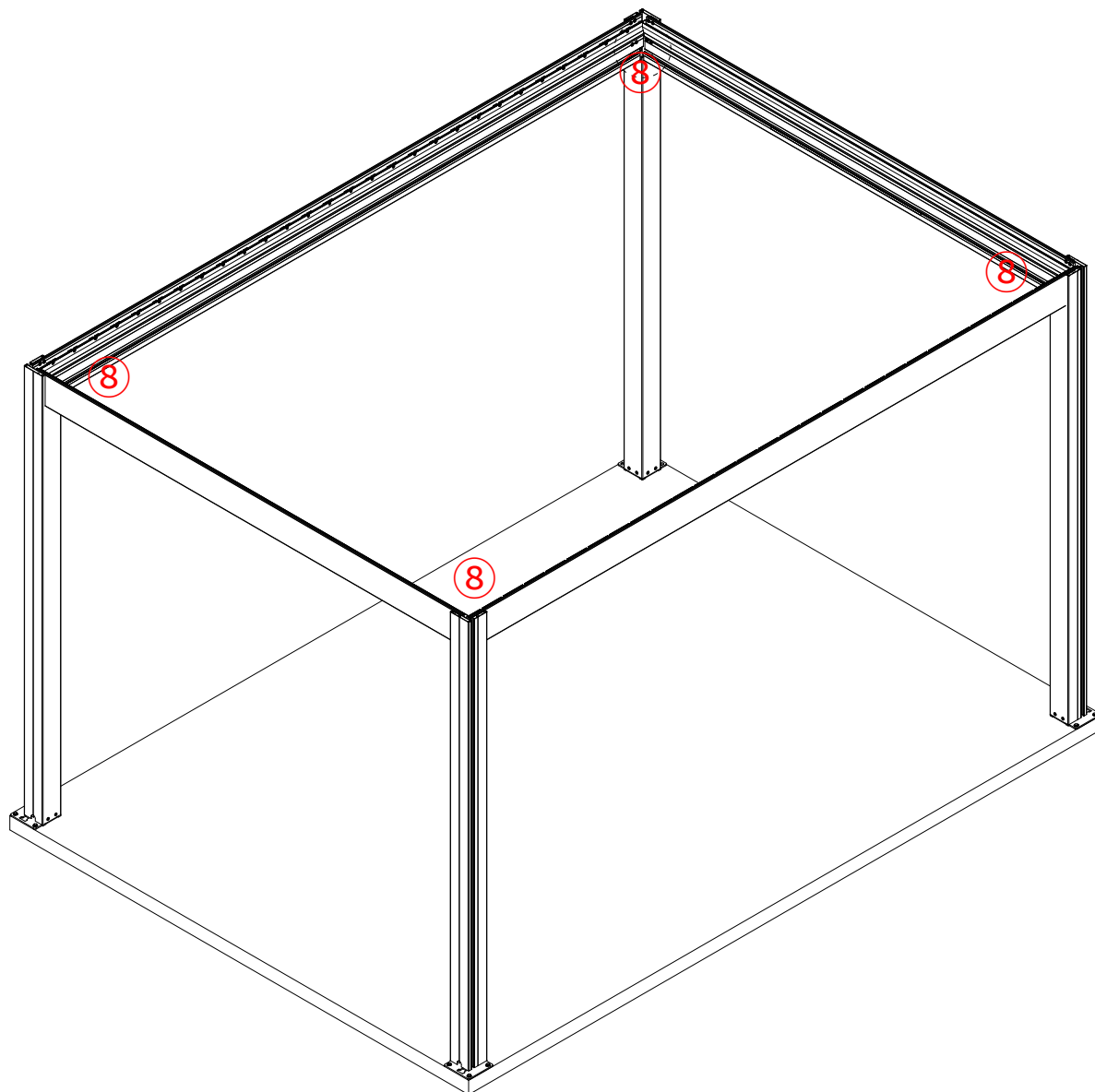

Passo 1

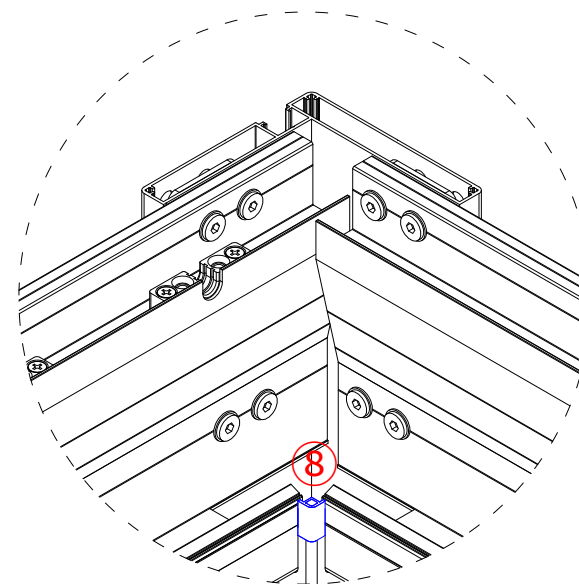

Passo 2

C-1

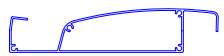

x 1

Instalando o Louvre

- 1) Conforme mostrado, a grelha de conexão do motor C-1 encaixa diretamente na ranhura.
- 2) Conecte o suporte do braço do motor à tampa final da grelha de conexão do motor C-1.

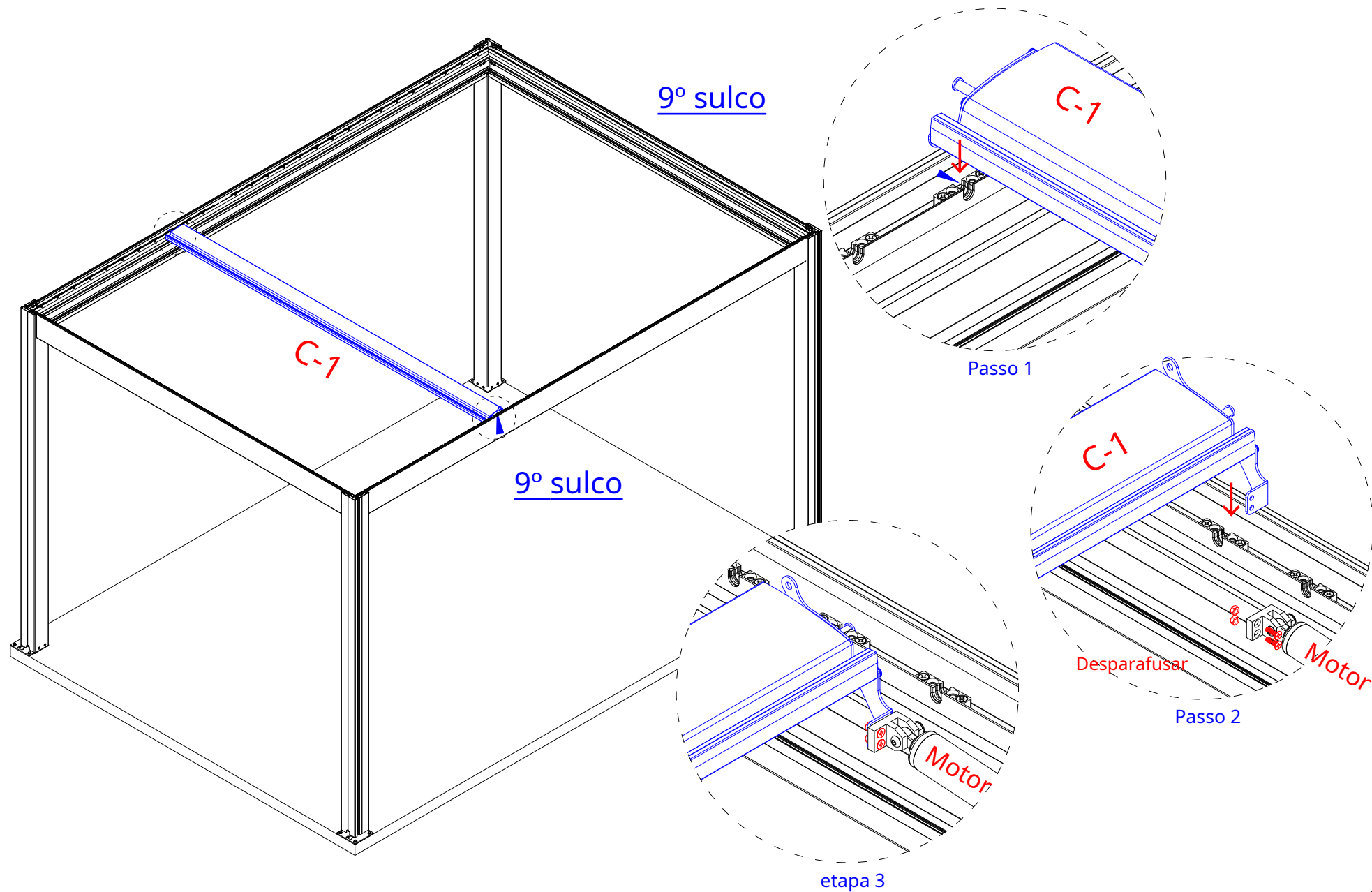

C-2 x 27



Instalando o Louvre

3) Conforme mostrado, a veneziana C-2 encaixa diretamente na ranhura.

27 peças
Louvre C-2

C-2

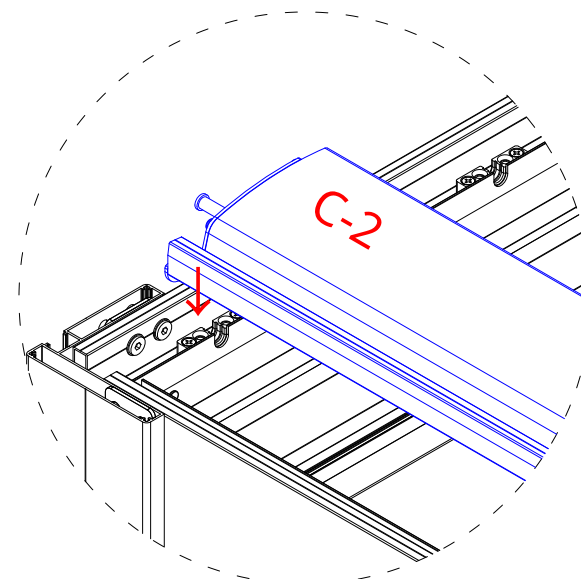
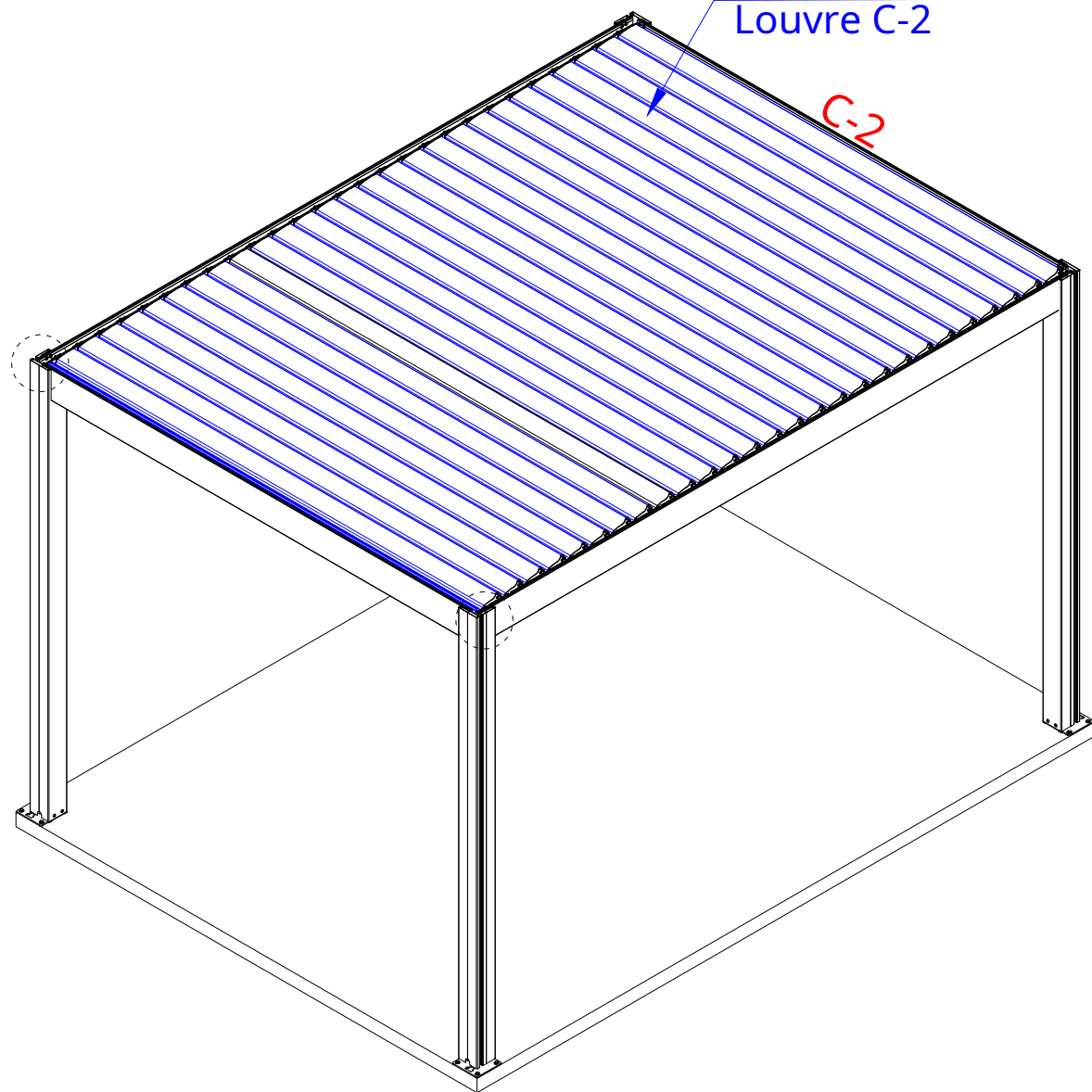

Passo 1

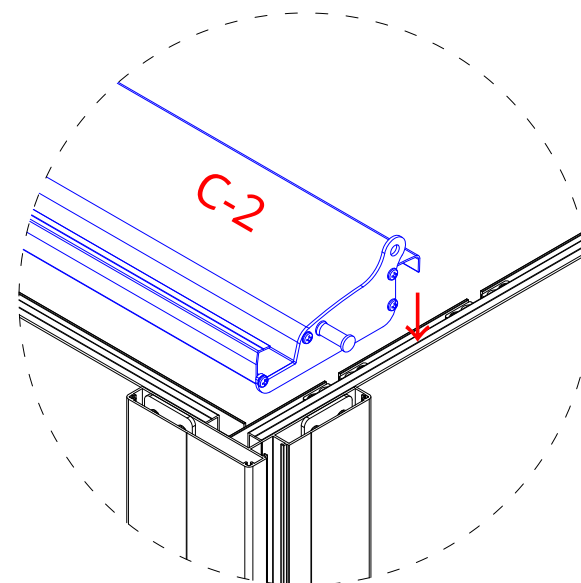

Passo 2

9

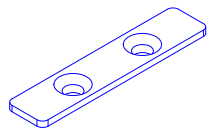

x 56

10



x 112

Instalando o Louvre

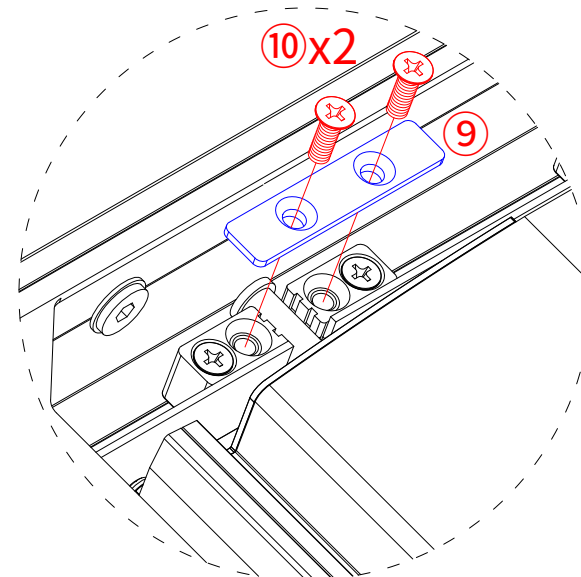
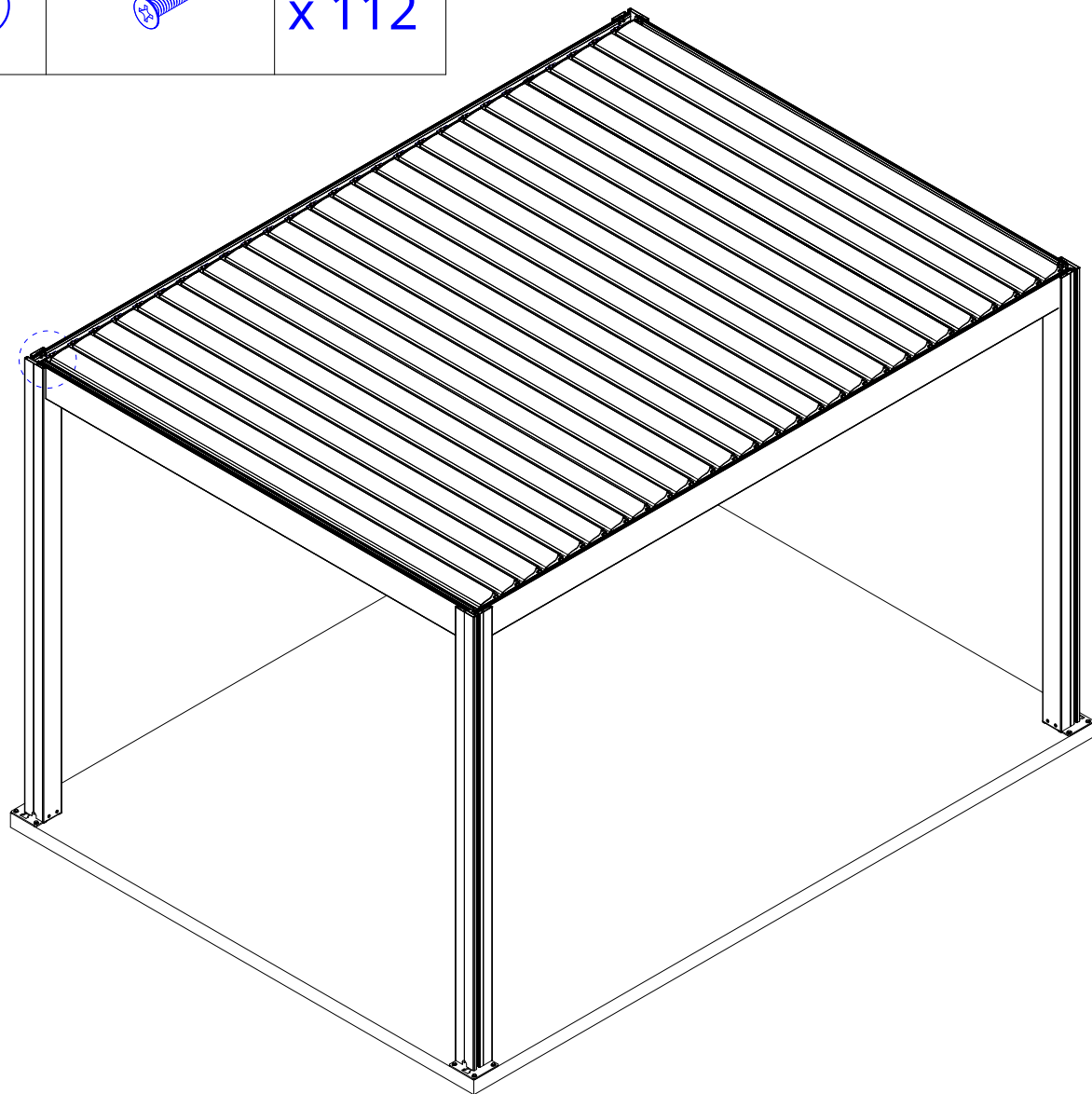

4) Conforme mostrado, fixe a tampa do suporte do eixo 9 a tampa do suporte de eixo com Parafuso escareado M5*16 10.

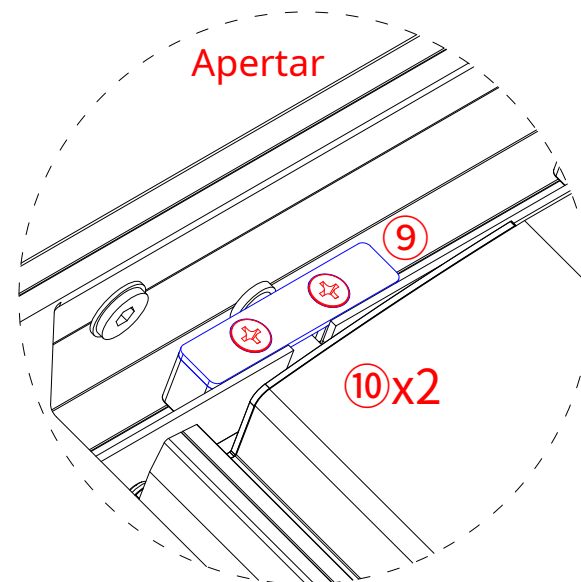

Passo 1



Passo 2

D		x 1
11		x 28

Instalando o Louvre

5) Conforme mostrado, use o parafuso hexagonal M6*5 11 através do furo (na haste de controle D) e depois fixado na veneziana.

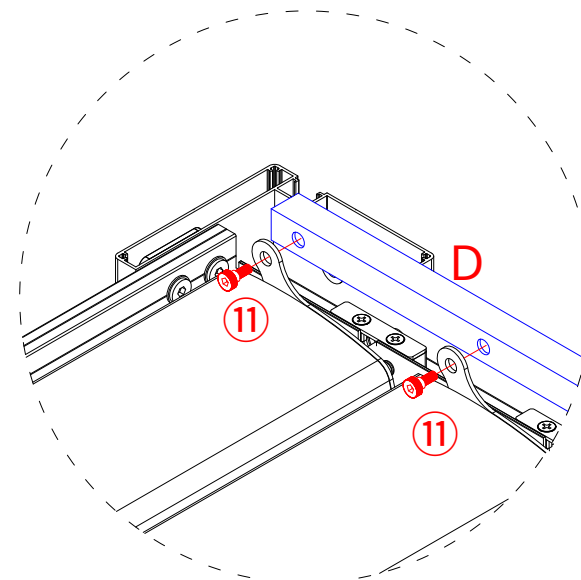
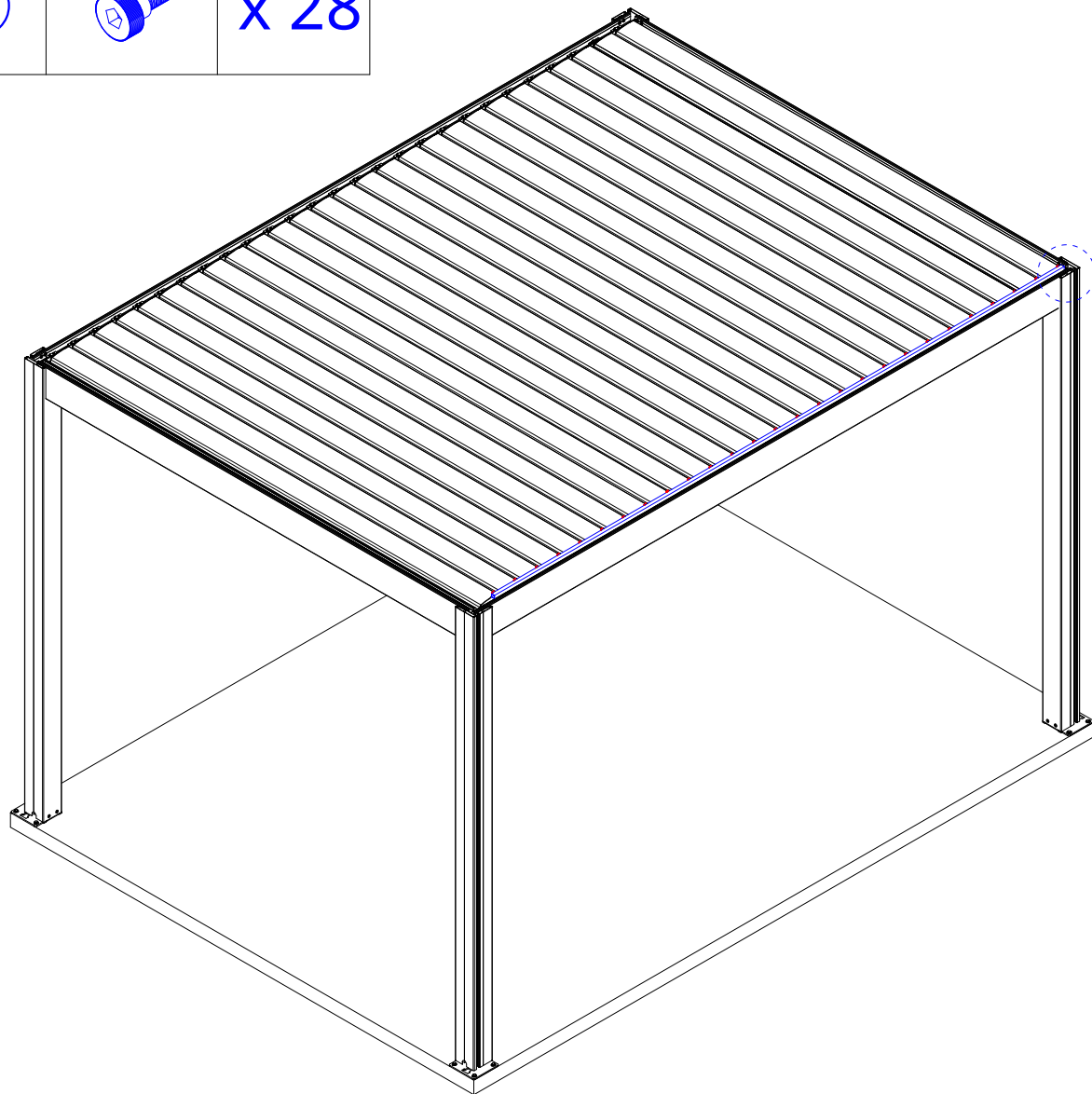

Passo 1

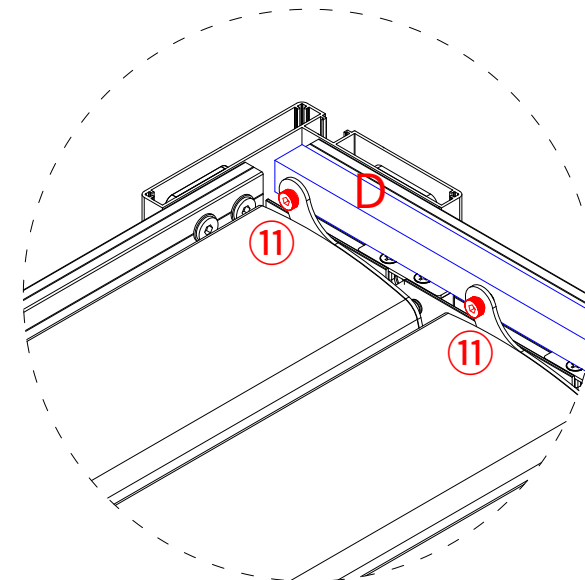

Passo 2

E



x 4

Consertar tampa do slot T

1) Conforme mostrado, insira a tampa da ranhura em T E na ranhura do poste.

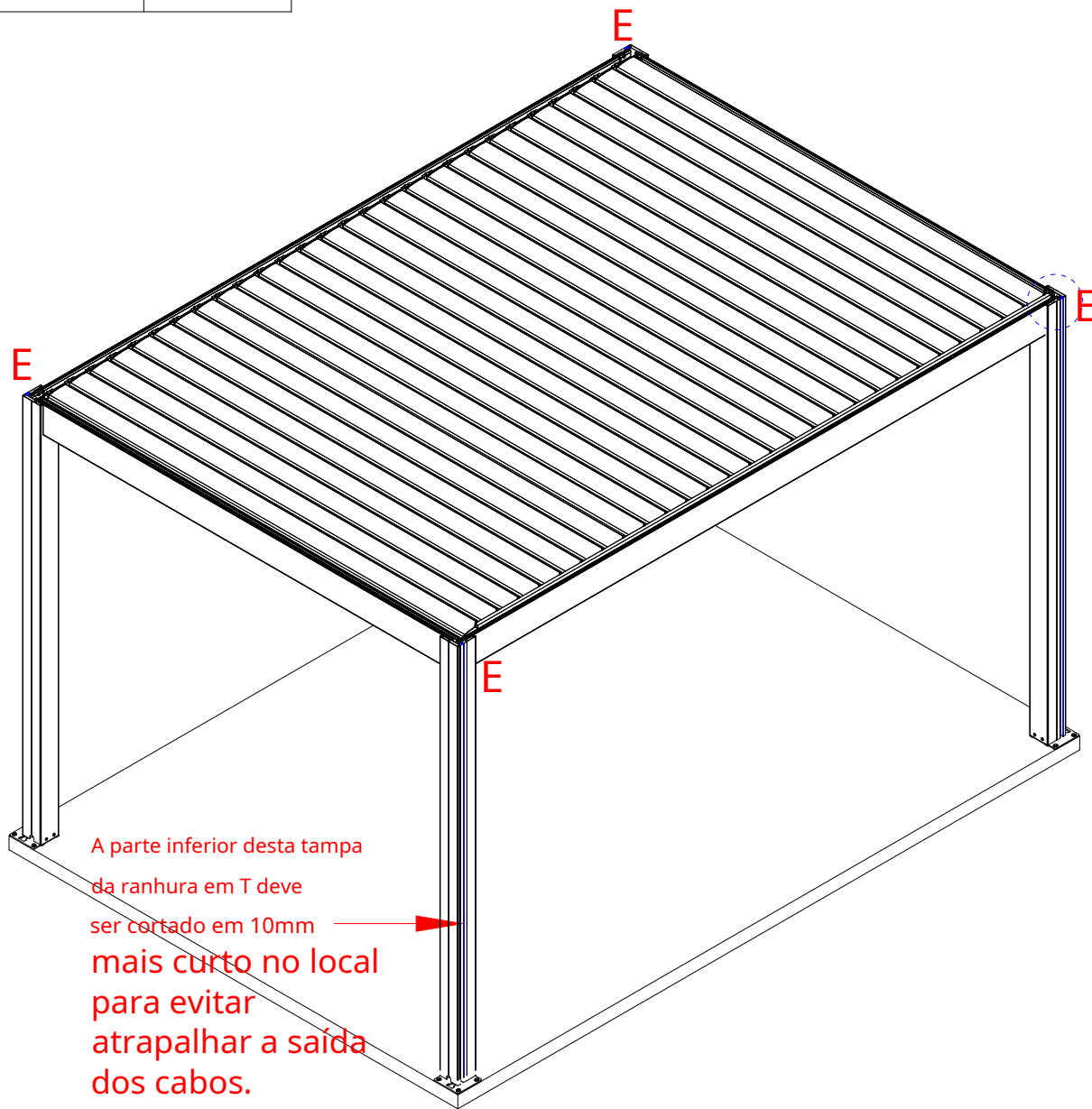

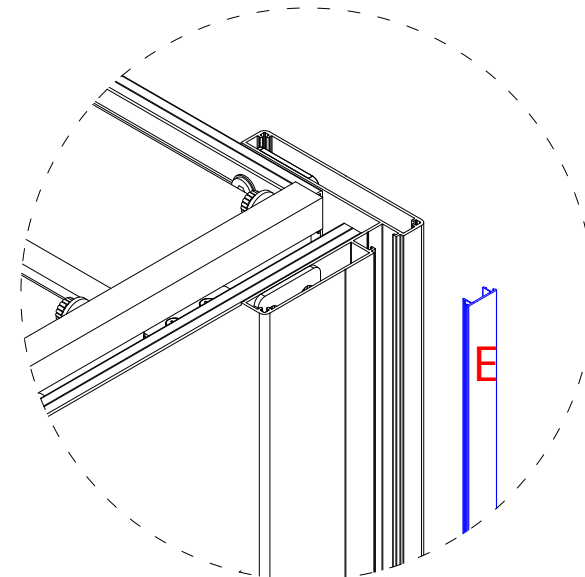

A parte inferior desta tampa da ranhura em T deve ser cortado em 10mm mais curto no local para evitar atrapalhar a saída dos cabos.

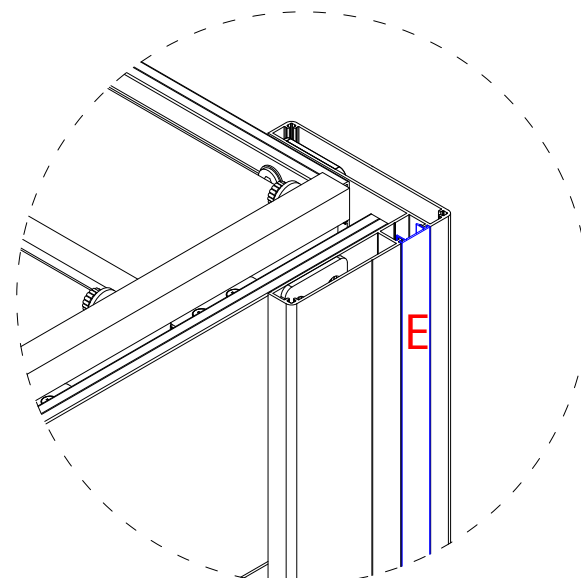

Passo 1

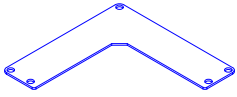

Passo 2

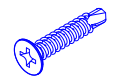
12		x 4
13		x 12
15		x 8

Fixe a tampa superior do poste

2) Conforme mostrado, coloque a placa da tampa em forma de L¹² na parte superior do poste e, em seguida, fixe-o com 3 dos parafusos auto-roscentes 4,2*16¹³ e 2 de 4,2*19 parafusos de cauda de perfuração¹⁵.

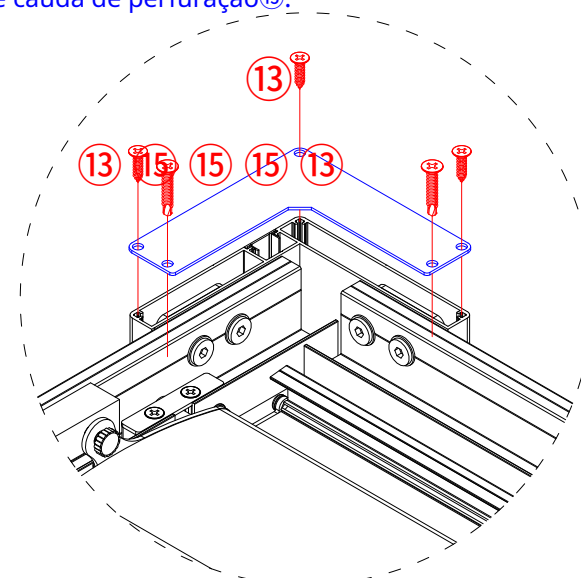
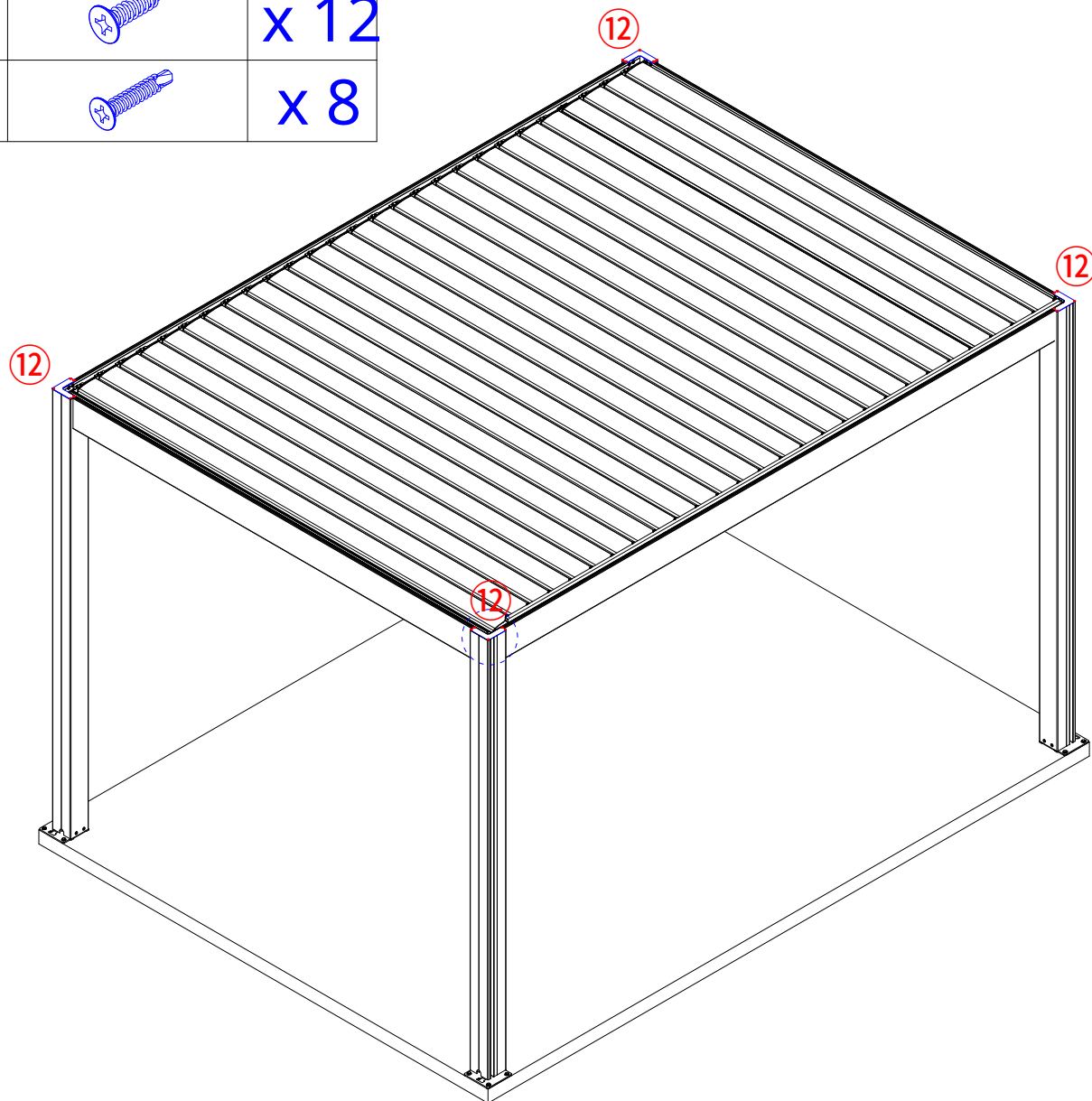

Passo 1

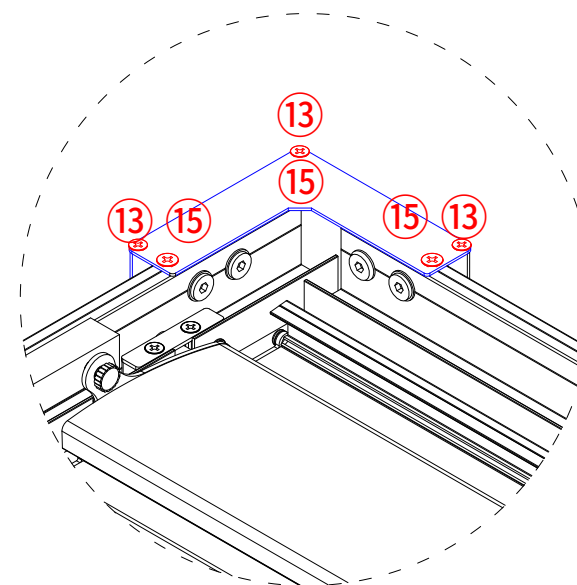

Passo 2

2

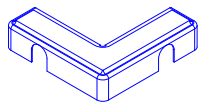

x 4

Instalando a tampa da placa base

1) Conforme mostrado, o entalhe em forma de U da tampa da placa de base deve ser orientado na mesma direção da abertura de drenagem. A tampa da placa de base no poste com entalhe de saída extra.

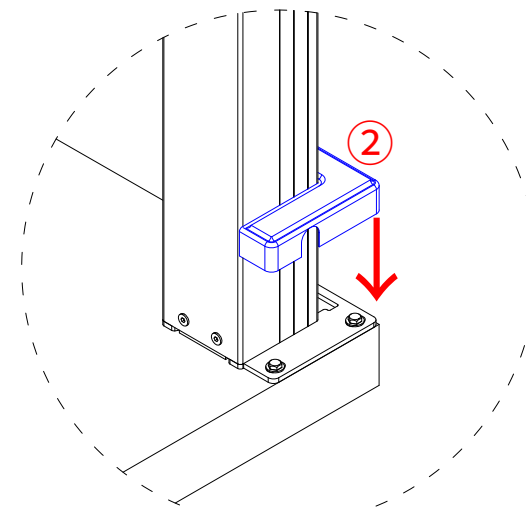
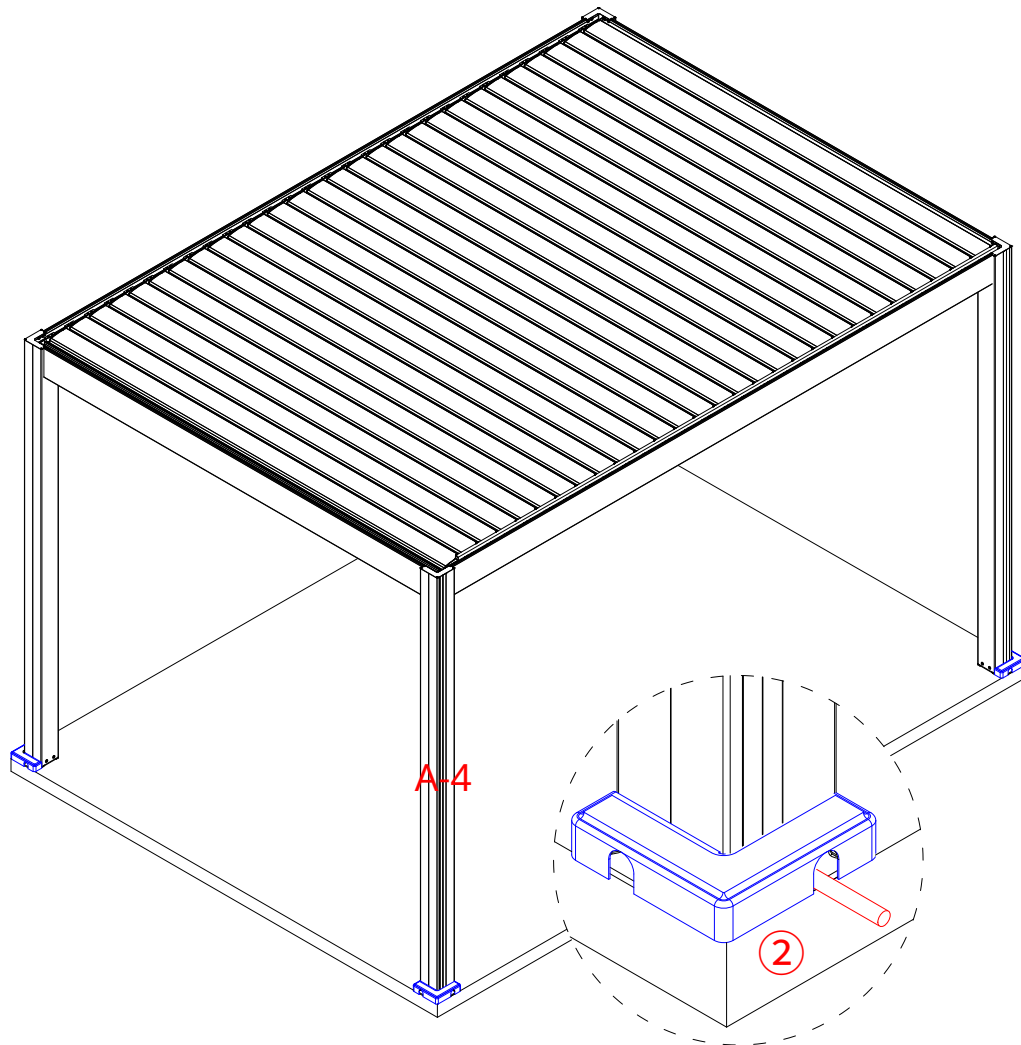

Passo 1

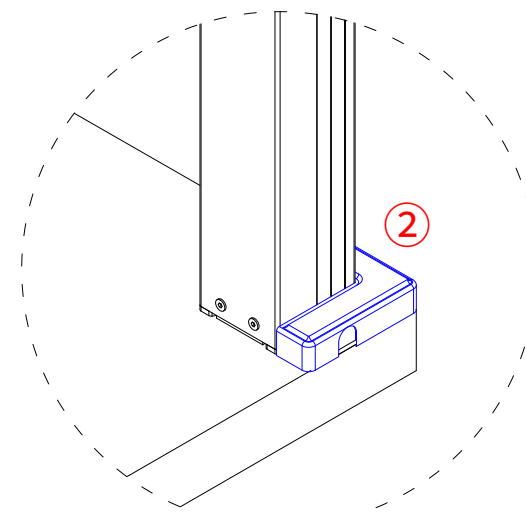

Passo 2

Quando o controle remoto e o receptor não conseguirem controlar o motor, siga as etapas abaixo para reprogramar.

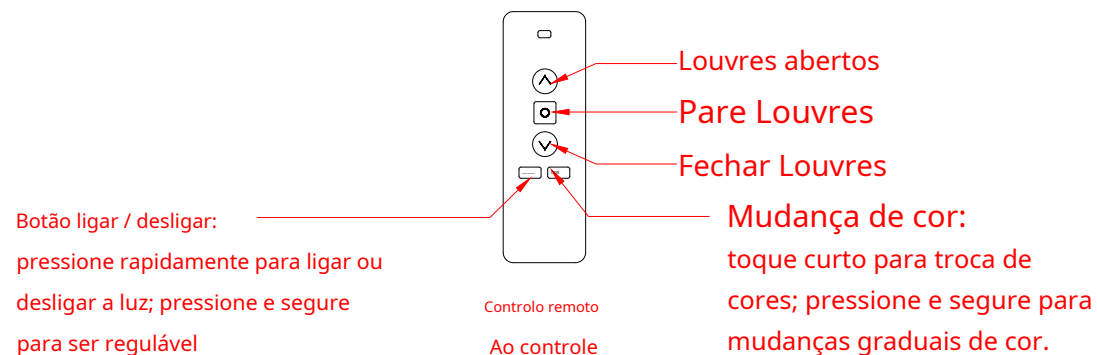

Etapas para emparelhamento:

1

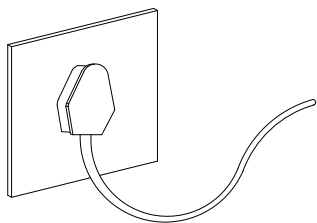

Desligue a energia por 15 segundos e reconecte a energia, então por favor inicie as etapas a seguir em 30 segundos.

2



Abra a tampa traseira do controle remoto/receptor, pressione e segure o Botão U2 por mais de 7 segundos.

3

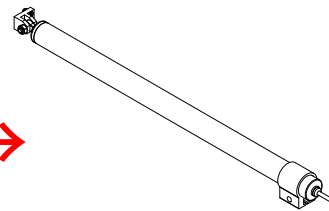

Quando o motor continua a fazer a "bipbipbip" som.

4

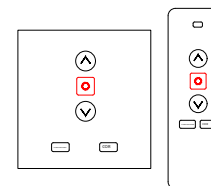

Pressione e segure o botão de parada do controle remoto/receptor por mais de 2 segundos novamente. Quando o "bipbipbip" som do motor desaparece, significa que o controle remoto/receptor foi emparelhado com sucesso.

Etapas de mudança de direção:

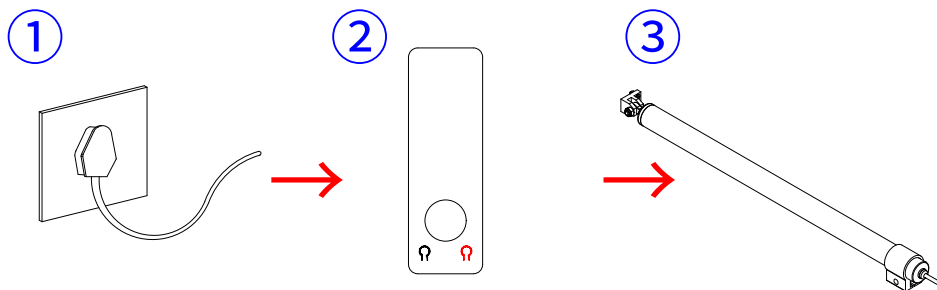

Desligue a energia por 15 segundos e reconecte o poder, então por favor inicie o seguindo os passos dentro 30 segundos.

Abra a tampa traseira do controle remoto/receptor, pressione e segure o **Botão U2** por mais de 7 segundos.

Quando o motor continua a fazer a "bipbipbip" som.

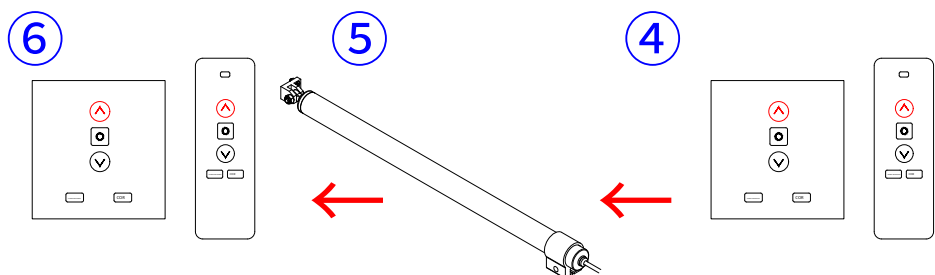

Pressione e segure o **botão para cima** do controle remoto por mais de 2 segundos.

O motor faz a "bipbipbip" soar novamente

Pressione e segure o **botão para cima** do controle remoto/receptor por mais de 2 segundos.

Etapas de exclusão de emparelhamento:

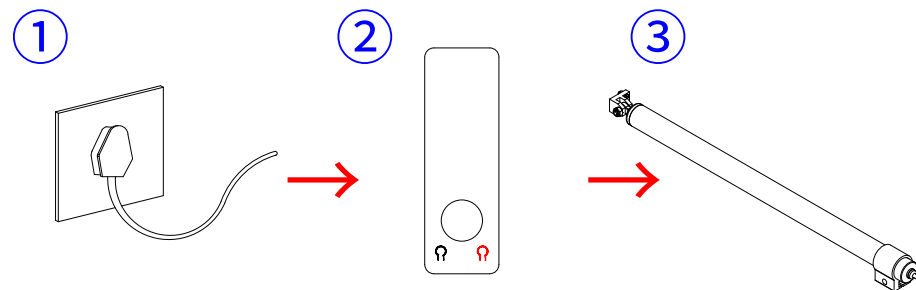

Desligue a energia por 15 segundos e reconecte o poder, então por favor inicie o seguindo os passos dentro 30 segundos.

Abra a tampa traseira do controle remoto/receptor, pressione e segure o **Botão U2** por mais de 7 segundos.

Quando o motor continua a fazer a "bipbipbip" som.

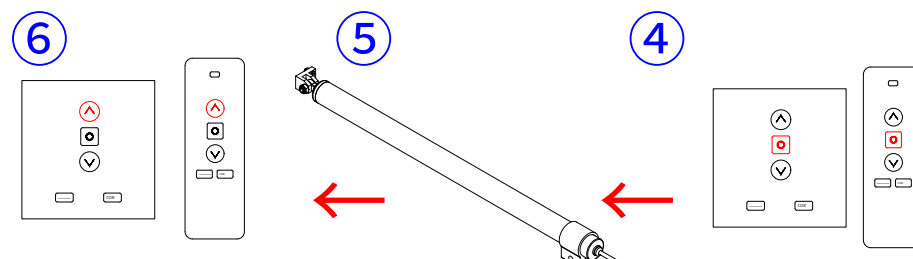

Pressione e segure o **botão para cima** do controle remoto/receptor por mais de 2 segundos. Exclua o emparelhamento com sucesso.

O motor faz a "bipbipbip" soar novamente

Pressione e segure o **botão de parado** do controle remoto/receptor por mais de 2 segundos.

Cuidando da sua pérgula

As superfícies estruturais revestidas com tintas em pó termoendurecíveis devem ser limpas uma vez por ano para manter a sua aparência estética original.

Os pós termoendurecíveis são sensíveis a:

- Fricção física, forte impacto, extrusão, produtos químicos, incluindo solventes alcalinos e solventes ácidos.
- Elementos naturais como vento, chuva, neve e luz solar prolongada. O exterior da pérgula pode deteriorar-se com o tempo e isso não será coberto pela garantia.

Limpando sua pérgula

- Não utilize esfregão, creme de limpeza, esponja abrasiva, bola de arame de ferro ou panos coloridos.
- Recomendado: Esponja macia, pano macio sem areia, algodão, algodão ou papel não tecido (somente branco).
- Não utilize produtos corrosivos, como produtos de limpeza ácidos ou alcalinos. Recomenda-se lavar com água com detergente de pH neutro e depois passar um pano para mantê-lo seco.
- Na limpeza com equipamentos de alta pressão, devem ser tomados os mesmos cuidados da limpeza da carroceria: distância, tipo de bico, temperatura e pressão da água devem ser considerados.

Usar lembrete

- Após a conclusão da instalação, verifique se os parafusos estão apertados. Lembre-se de verificar os parafusos pelo menos uma vez por ano.
- **Em caso de previsão de queda de neve, granizo ou ventos fortes superiores a 80 km/h, recomenda-se abrir as lâminas das venezianas. Não opere as lâminas em caso de geada ou neve. Retire as lâminas da pérgula quando a neve for abundante.**
- Verifique regularmente as condições de vedação para garantir que as vedações ou outros componentes não vazem.
- Limpe regularmente detritos, como folhas caídas na pérgula, para evitar o bloqueio do ralo.
- Restrições de utilização: Os sistemas estanques, embora eficazes, não são concebidos para garantir uma impermeabilização completa. Chuvas fortes e ventos fortes podem danificar a pérgula. Qualquer dano ocorrido não será coberto pela garantia.

PRIROČNIK ZA UPORABO

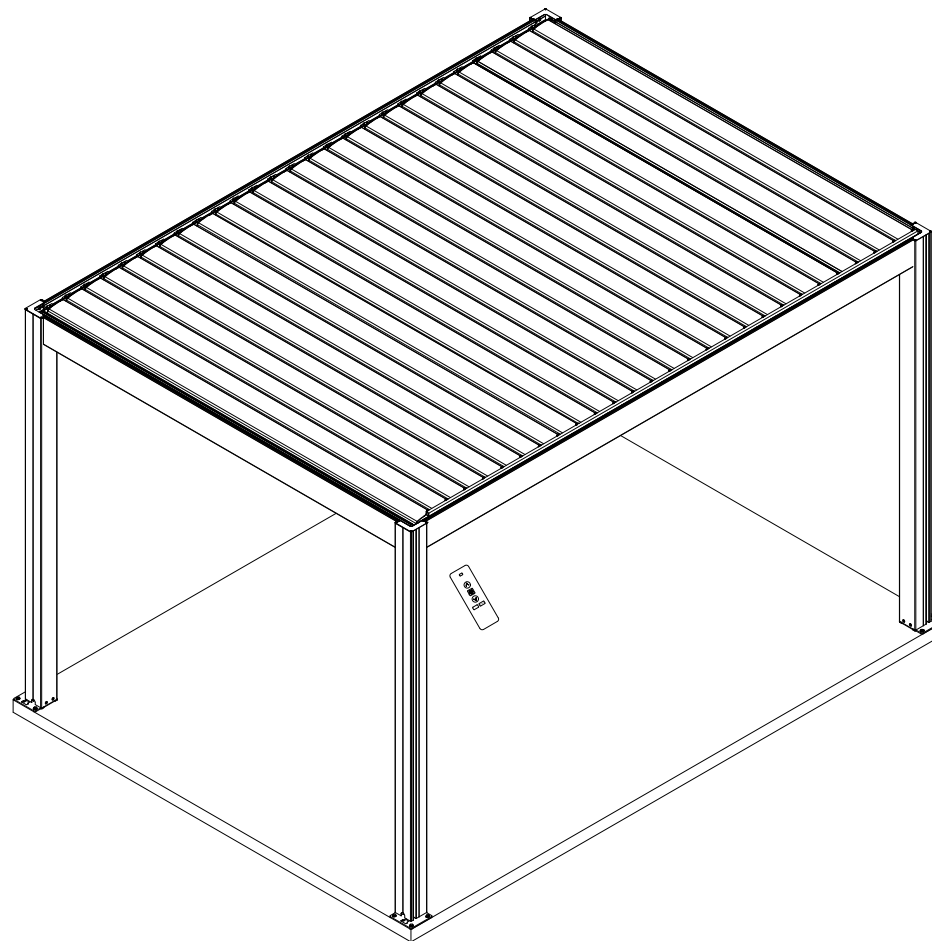

OTHER LANGUAGES

Pergola 4 x2.86m

Pred prvo uporabo vaše pergole preberite ta priročnik.
Prosimo, shranite ta priročnik za poznejšo uporabo.

Pergola

Otvoritev: Električni

Velikost: 295.3 (Dolžina) x 409 (Premer) -cm

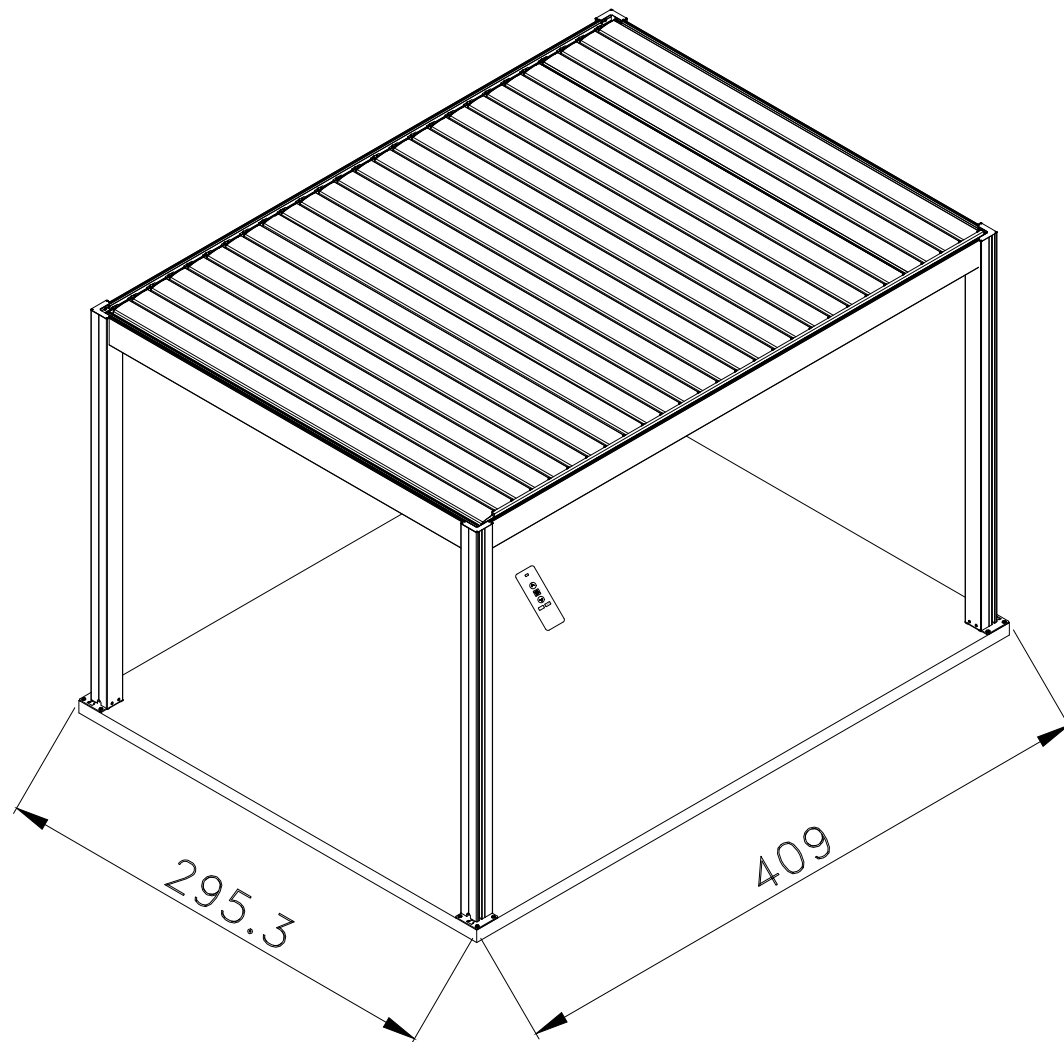

Opombe pri namestitvi:

1. Namestitev zahteva najmanj tri osebe: ena za merjenje in označevanje, ena za namestitev in ena kot pomočnik.
2. Na voljo so samo pritrdilni elementi za betonska tla. V primeru, da na terenu ni betonske plošče, se priporoča izdelava betonskih plošč pri vsakem stebru. Betonska plošča mora biti najmanj 500x500x500 mm.
3. Ko je okvir pergole sestavljen, s kotnikom, libelo in ravnilom izmerite nivo in diagonalo izdelka, da zagotovite velikost pergole. Podlage morajo biti natančno poravnane brez toleranc.
4. Pergolo je treba priviti na tla. Ne vzamemo nobenega odgovornost, če ploščice med vrtanjem vijakov počijo.
5. Potrebna so električna orodja: poskrbite, da pravilno delujejo in upoštevajte varnostna navodila.
6. Bodite previdni pri uporabi ostrih orodij.
7. Nosite zaščitna oblačila, vključno z zaščitnimi očali, čeladami in rokavicami.
8. Ne plezajte in ne stojte na strehi.

Varnostno opozorilo

- . Pri sestavljanju je zelo priporočljivo nositi rokavice.
- . Pergole ne nameščajte v slabih vremenskih razmerah, kot sta veter ali dež.
- . Ne dotikajte se žic z aluminijastimi profili.
- . Pri nameščanju pergole vedno nosite zaščitne čevlje in očala.
- . Vse plastične vrečke hranite izven dosega otrok.
- . Steber pergole mora biti nameščen in pritrjen na ravno površino.
- . Med montažo se ne naslanjajte na steber.
- . Ne dovolite, da bi se otroci približali prizorišču med fazo sestavljanja.
- . Ne bodite blizu pergole v nevihti ali tajfunu.
- . Ne poskušajte plezati na pergolo pod vplivom alkohola ali mamil.
- . Pri uporabi lestev ali podobnih orodij in električnih orodij med fazo montaže upoštevajte varnostna priporočila proizvajalca.
- . Vroče orodje, kot je električni vrtalnik, ne sme biti v stiku s profilom pergole.
- . Pred namestitvijo stebra se prepričajte, da pod zemljo ni skritih kablov ali drugih kablov.

Splošni nasveti

- . Ta pergola je sestavljena iz več sestavnih delov, sestavljanje pa traja najmanj 90 minut. Pergola ne sme biti postavljena pod drevo.
- . Če steber povežete neposredno s cementom ali podobno podlago, uporabite predhodno izvrtane luknje na priloženi podlagi.
- . Pred montažo preverite število profilov in okovja ter jih uporabite v skladu s seznamom okovja profilov za enostavno montažo.
- . Majhne koščke, kot so vijaki, dajte v posodo, da preprečite izgubo.
- . Prosimo, bodite pozorni na položaj prenosa na žarku, da preprečite napačno namestitev.
- . Z pergole redno čistite listje, sneg ali druge predmete.

Vzdrževanje in popravilo

- . Za čiščenje pergole uporabite blag detergent in ga sperite z vodo. Za čiščenje površine aluminijastega profila ne uporabljajte acetona ali abrazivnih čistil.

Garancija

- . Splošna garancija za razbarvanje je 5 let, za motor in LED osvetlitev 2 leti.

Orodja za zaščito in namestitev

Zaščitna oprema:

1. Čelada
2. Rokavice
3. Komplet prve pomoči v sili
4. Zaščitna očala



Merilni instrument:

1. Merilni trak (5 metrov ali več)
2. Kvadratno ravnilo
3. Raven

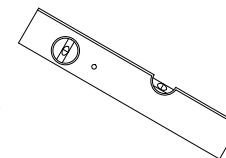
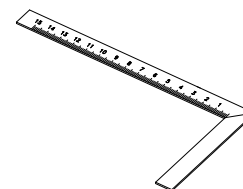
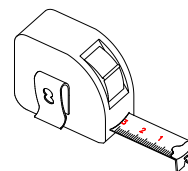



Orodja:

1. 2-metrski lestev (1,5 metra ali več)
2. 13 mm imbus ključ
3. 17 mm imbus ključ
4. Električni vrtalnik
5. Električni sveder (10 mm sveder)
6. Marker ali svinčnik
7. Gumijasto kladivo
8. Pištola za tesnilno maso in lepilo





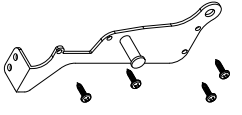
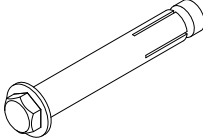
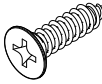
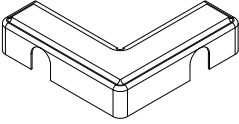
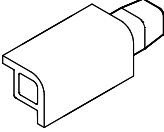
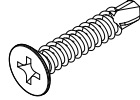
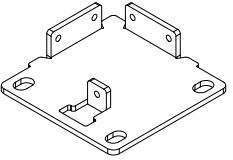
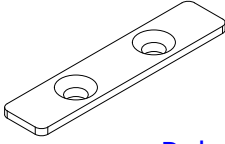
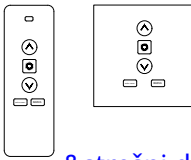
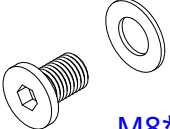

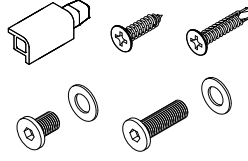
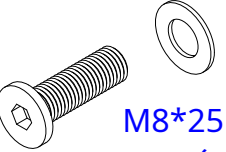
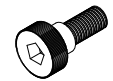
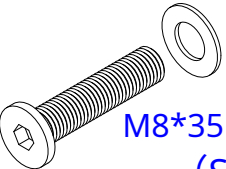
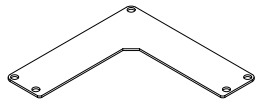

Silicon

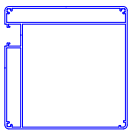
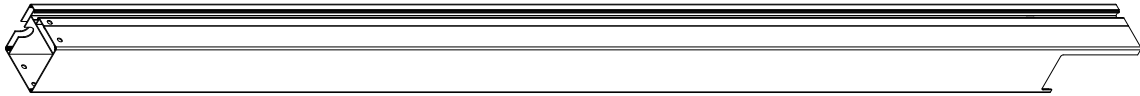
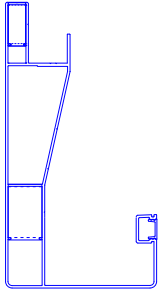
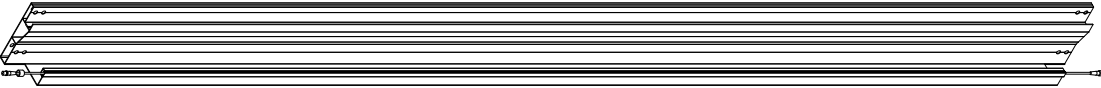
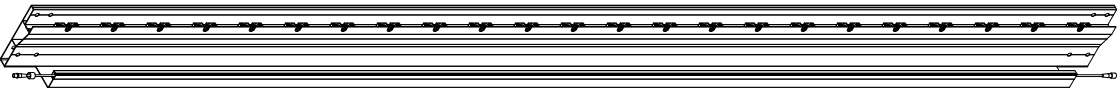
Seznam dodatkov in vijakov

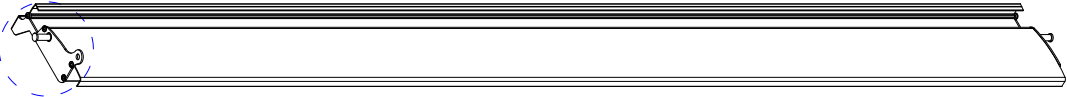
<p>①</p>	 <p>x 1 Končna kapica za Rešetka za povezovanje motorja & 4*20 vijaki z ravno glavo</p>	<p>⑦</p>	 <p>x 16 Raztezni vijak M8*80</p>	<p>⑬</p>	 <p>x 12 4,2*16 vijak z ravno glavo</p>
<p>②</p>	 <p>x 4 Pokrov osnovne plošče</p>	<p>⑧</p>	 <p>x 4 Post Corner Podaljšek</p>	<p>⑭</p>	 <p>x 8 4,2*19 vrtalni vijak</p>
<p>③</p>	 <p>x 4 Osnovna plošča</p>	<p>⑨</p>	 <p>x 56 Pokrov držala gredi</p>	<p>⑮</p>	 <p>x 1 Sprejemnik & strešni daljinski upravljalnik</p>
<p>④</p>	 <p>x 16 M8*12 šestrobi vijaki (S podložko)</p>	<p>⑩</p>	 <p>x 112 M5*16 vgrezni vijak</p>	<p>⑯</p>	 <p>x 1 Rezervni deli</p>
<p>⑤</p>	 <p>x 16 M8*25 šestrobi vijaki (S podložko)</p>	<p>⑪</p>	 <p>x 28 M6*5 šestrobi vijak</p>	<p>⑰</p>	
<p>⑥</p>	 <p>x 16 M8*35 šestrobi vijaki (S podložko)</p>	<p>⑫</p>	 <p>x 4 L zgornji pokrov stebra</p>	<p>⑱</p>	

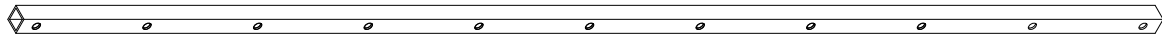
Seznam profilov

<p>A-1 ~ A-4</p>			<p>x 4 Objavi</p>
<p>B-2 B-4</p>			<p>x 2 Greda in žleb</p>
<p>B-1</p>			<p>x 1 Greda in žleb (z držalom gredi)</p>
<p>B-3</p>			<p>x 1 Nosilec in žleb (z držalom gredi) + motor</p>
<p>C-1</p>			<p>x 1 Motorna povezovalna rešetka</p>
<p>C-2</p>			<p>x 27 Louvre</p>
<p>D</p>			<p>x 1 Krmilna palica</p>
<p>E</p>			<p>x 4 Pokrov T-reže</p>

Risba postavitve aluminijastih profilov

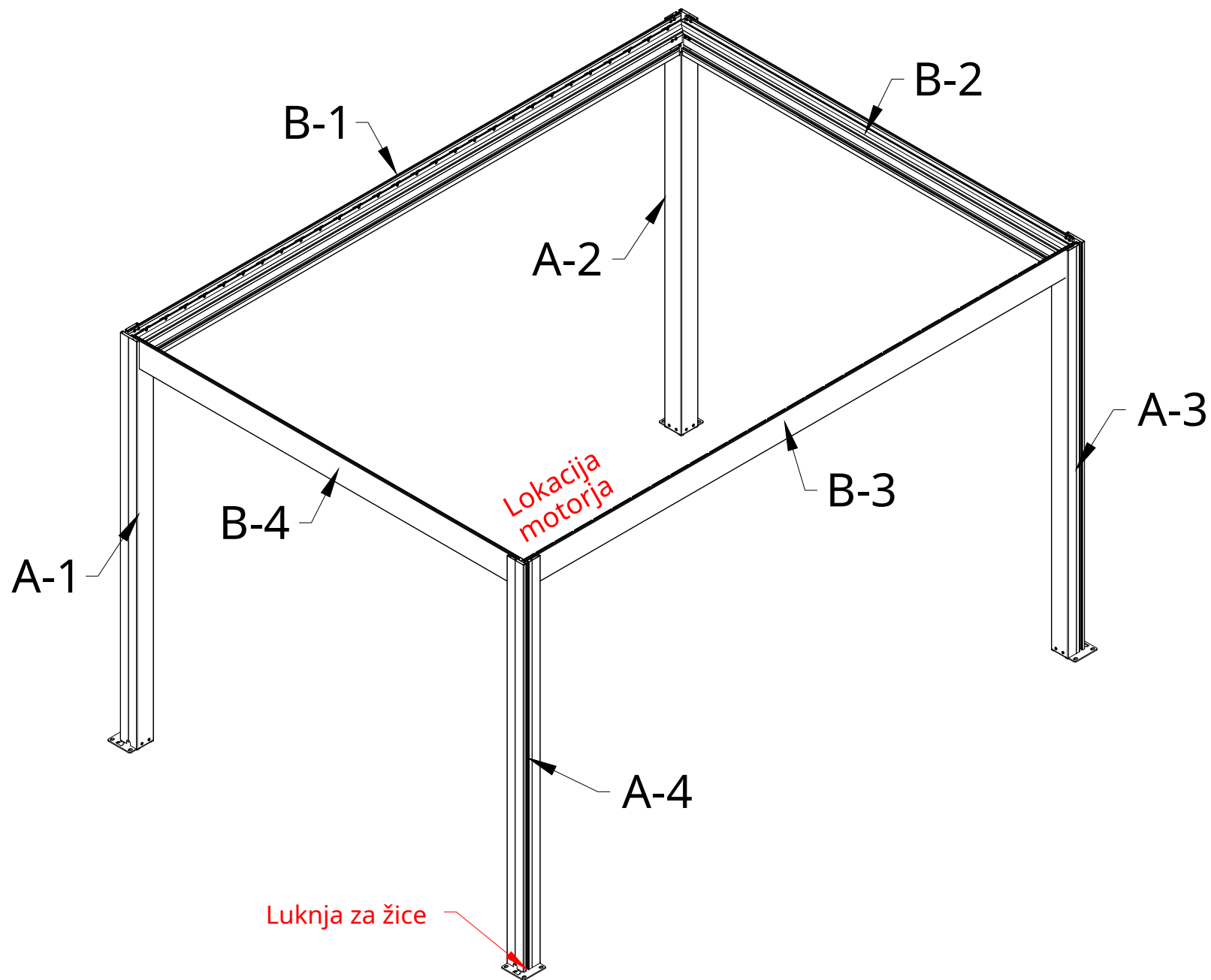

1

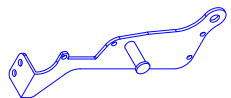

x 1



x 4

Namestitev loput za priključitev motorja

1) Pritrdite pokrov rezila na reže za povezavo motorja C-1 z vijaki s plosko glavo 4*20.

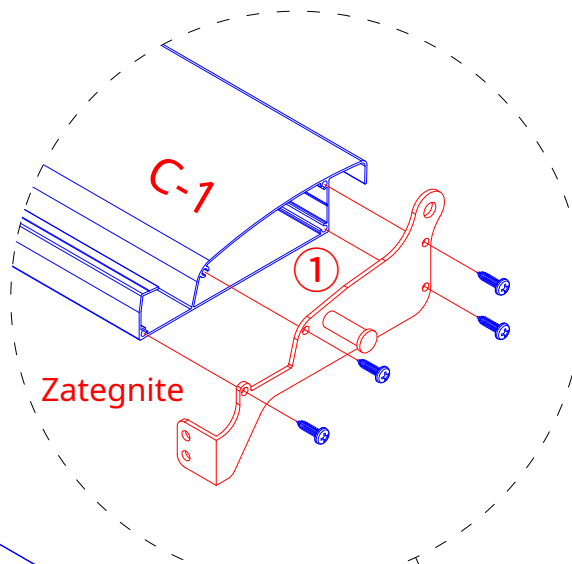

Korak 1



Če je mesto namestitve
utesnjeno, lahko pokrove rezil
namestite po namestitvi ogrodja.

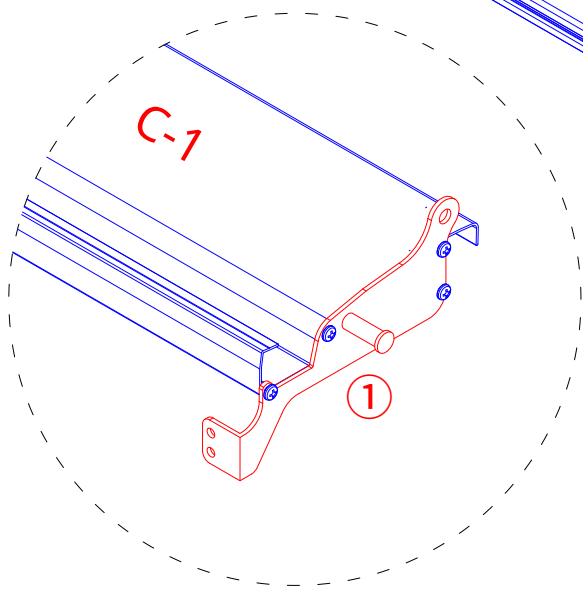

2. korak

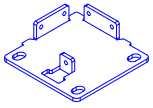
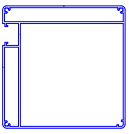
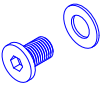
③		x 4	A-1 ~ A-4		x 4
④		x 16			

Sestavite ogrodje

1) Kot je prikazano, vstavite pokrov osnovne plošče ② v objave, nato poravnajte luknje v osnovni plošči ③ z luknjami v drogovih in zaklenite osnovno ploščo ③ na stebre s šestrobnimi vijaki M8*12 (s podložko) ④.

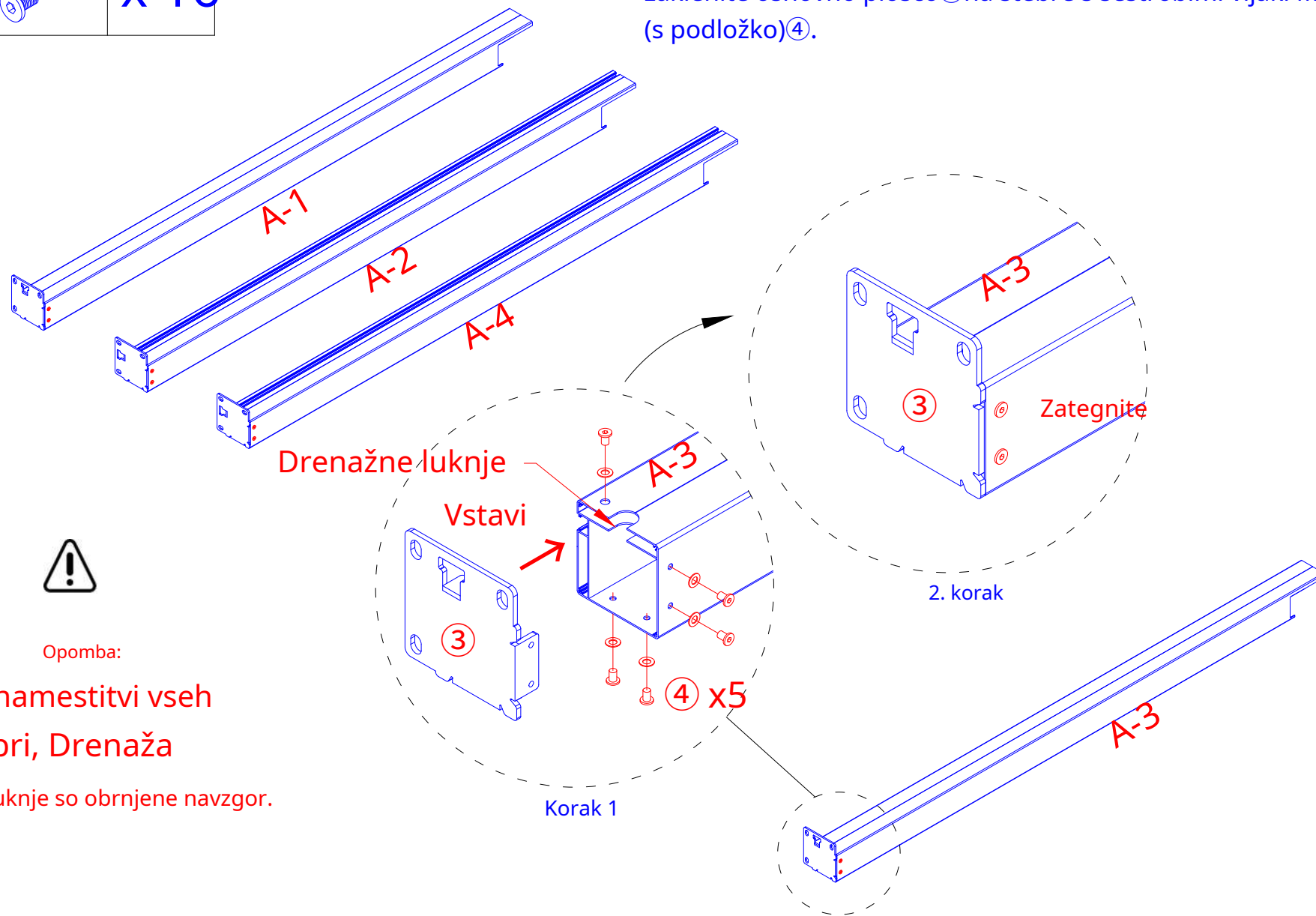

B-1 B-3		x 2
⑤		x 8
⑥		x 8

Sestavite ogrodje

2) Kot je prikazano, vstavite nosilec in žleb (B-1, B-3) v objavo, nato popravil tram in žleb (B-1, B-3) na drogove s šestrobimi vijaki M8*25⑤ in šestrobi vijaki M8*35⑥.

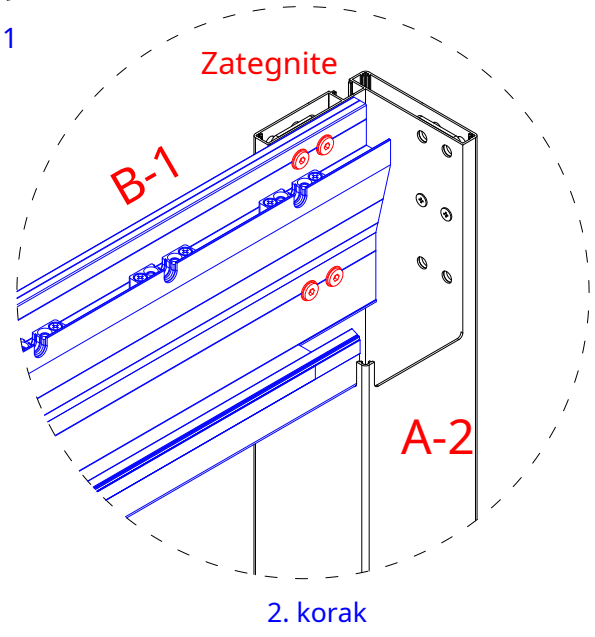
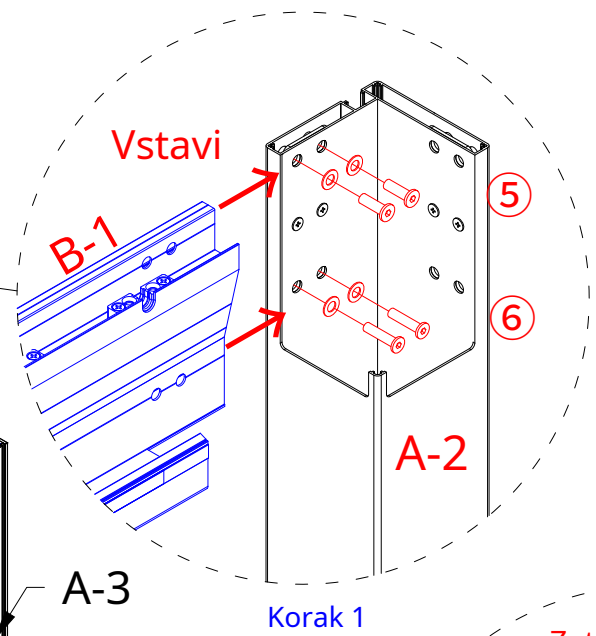
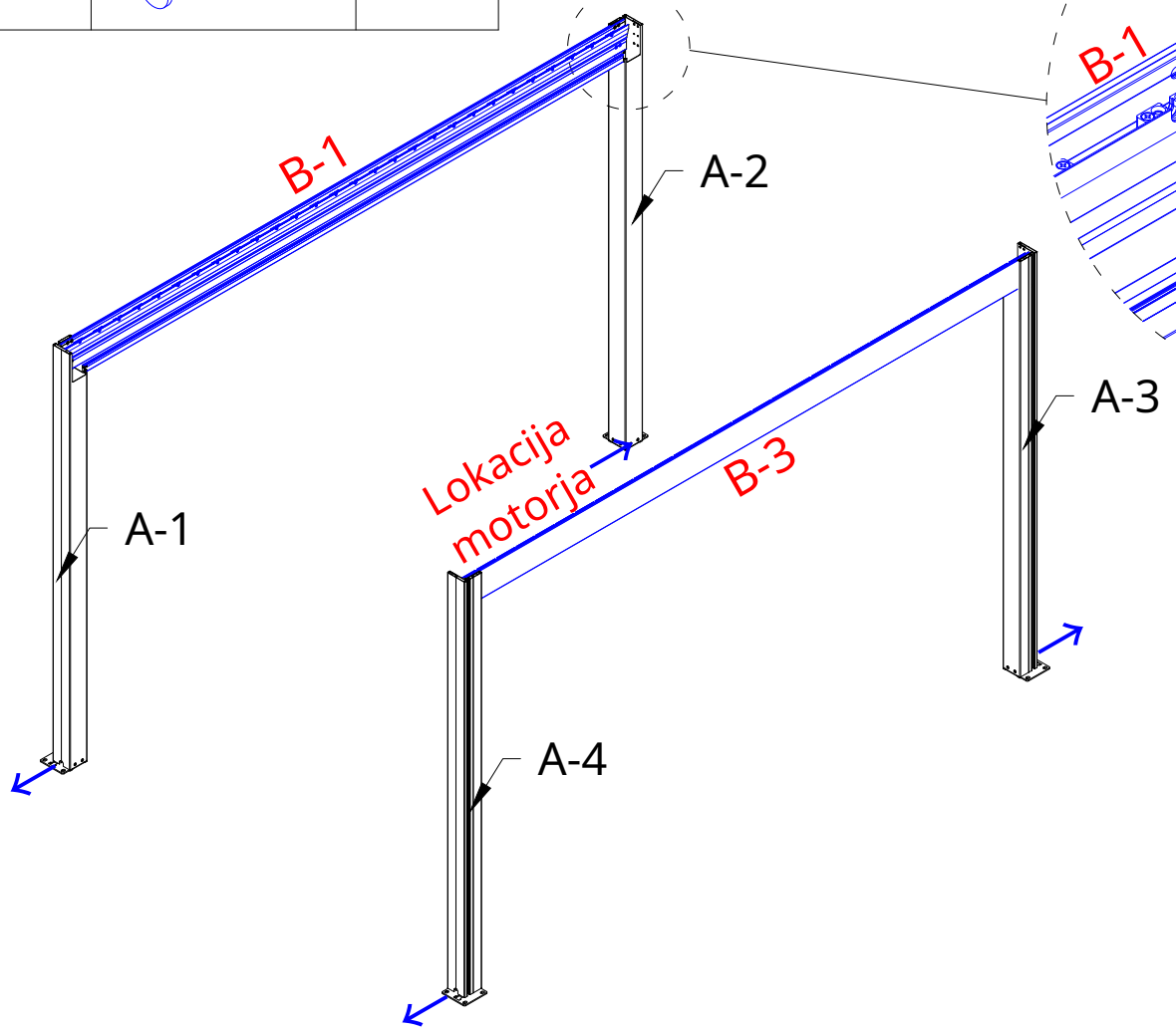

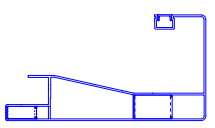
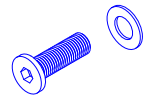
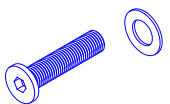
B-2 B-4		x 2
⑤		x 8
⑥		x 8

Sestavite ogrodje

3) Kot je prikazano, vstavite nosilec in žleb B-2, B-4 v objavo, nato popravil gred in žleb B-2, B-4 na drogove s šestrobimi vijaki M8*25^⑤ in šestrobi vijaki M8*35^⑥.

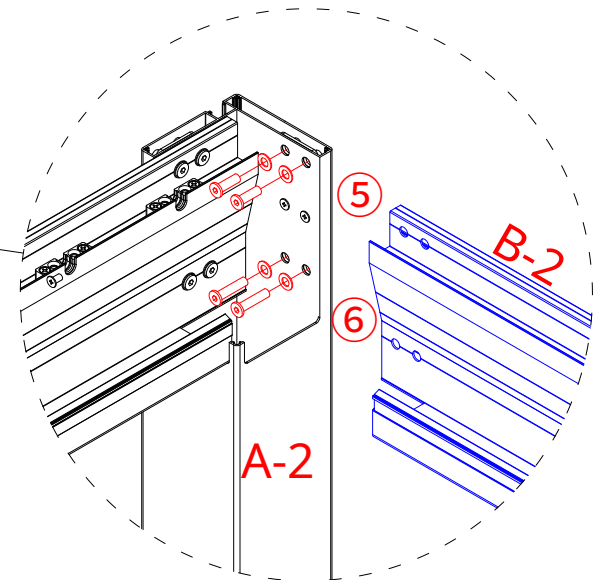
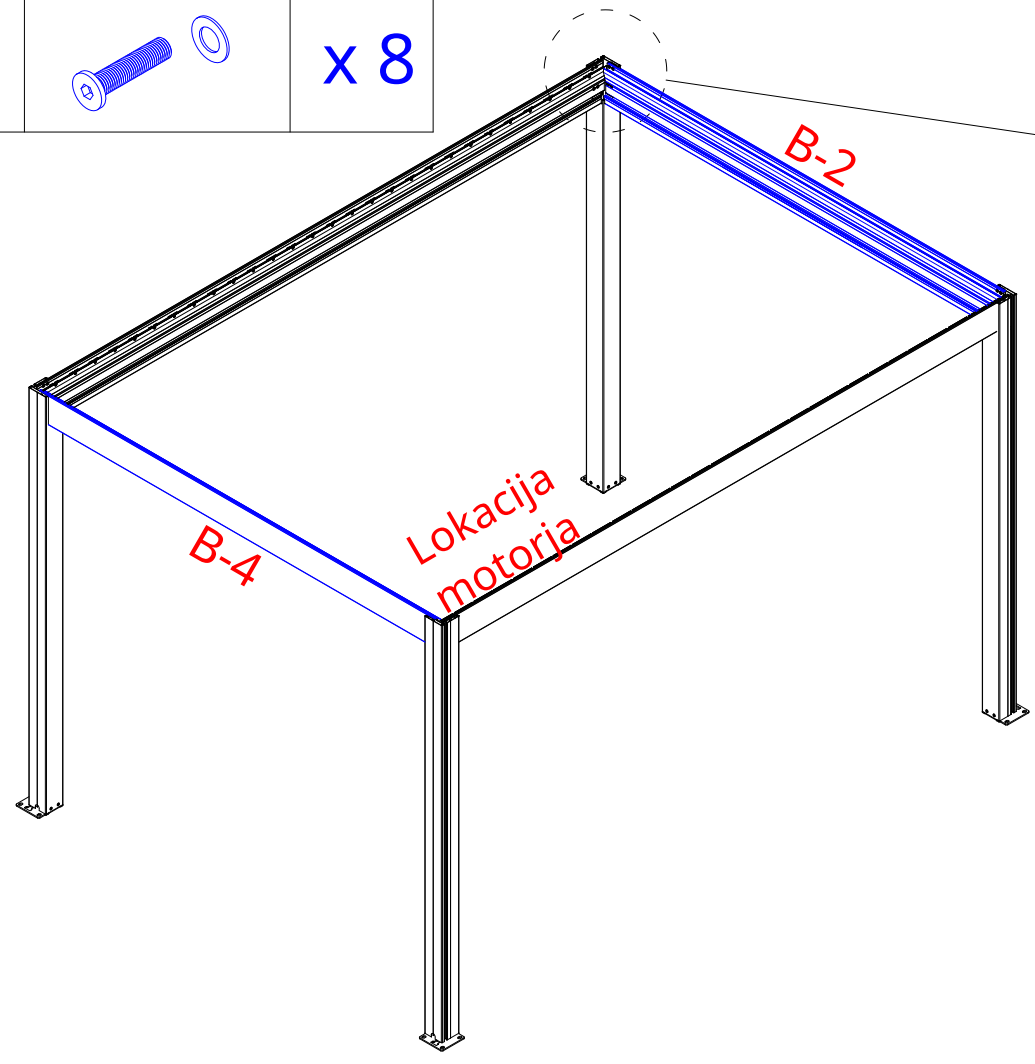

Korak 1

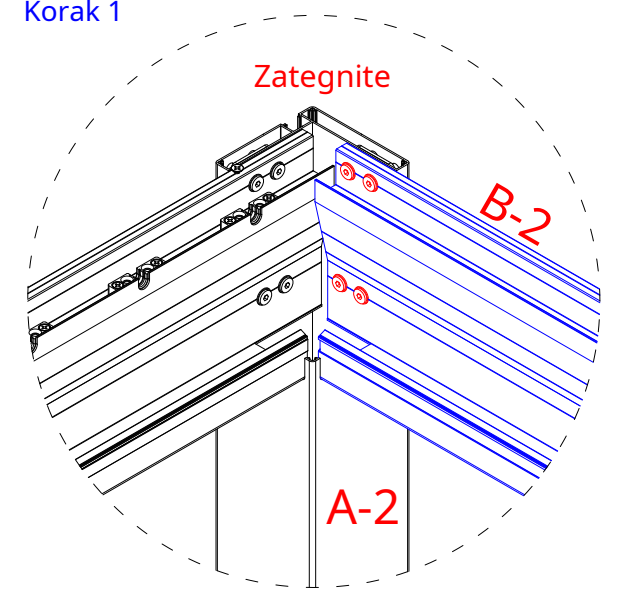

2. korak

7

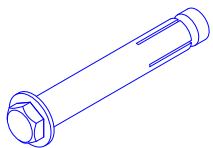

x 12

Opomba:

Preven pritrnite osnovno ploščo, morate zagotoviti, da so diagonale 4 stebrov enake dolžine. Prepričajte se, da je velikost $W1=W2$, $W3=W4$.

Pritrdite pergolo na tla

- 1) Uporabite raztezni vijak 12 M8*80 ⑦ če so tla betonska. Če ne, boste morali poiskati drugo rešitev za pritrnitev pergole na železo površino.
- 2) Premaknite pergolo v ustrezen položaj za namestitev, nato s svinčnikom označite položaj štirih stebrov, odstranite pergolo in z električnim vrtalnikom naredite 12 luknje glede na oznako. Premaknite pergolo nazaj na položaj in pritrnite osnovno ploščo z razteznim vijakom M8*80 ⑦.

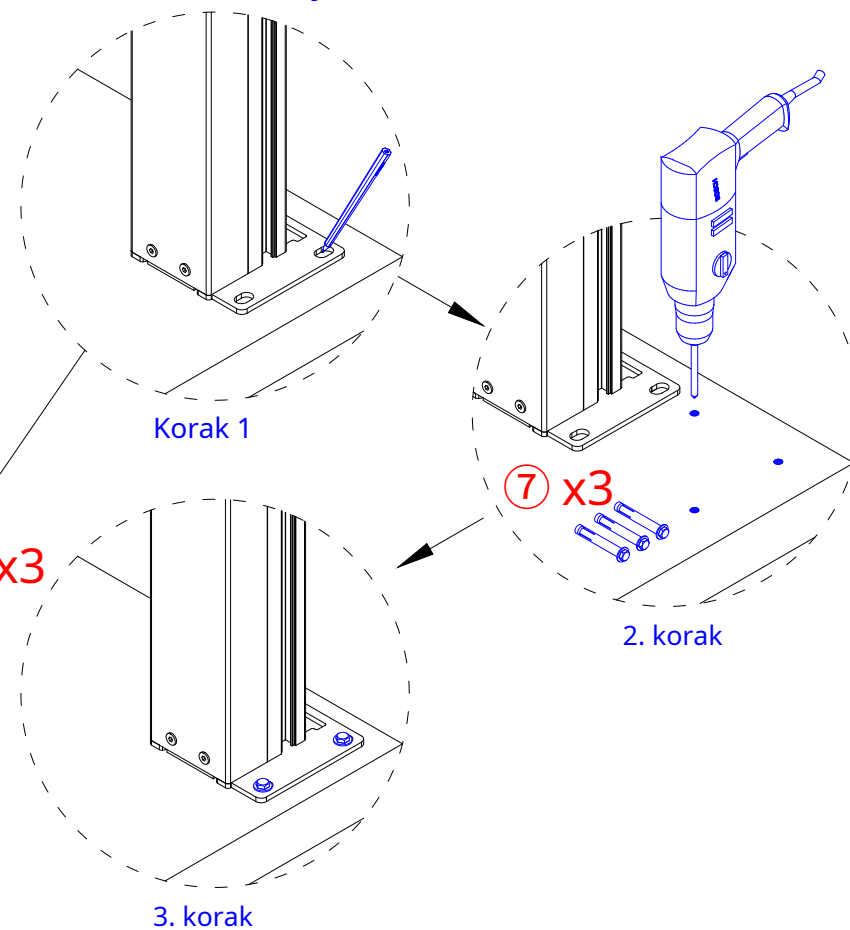
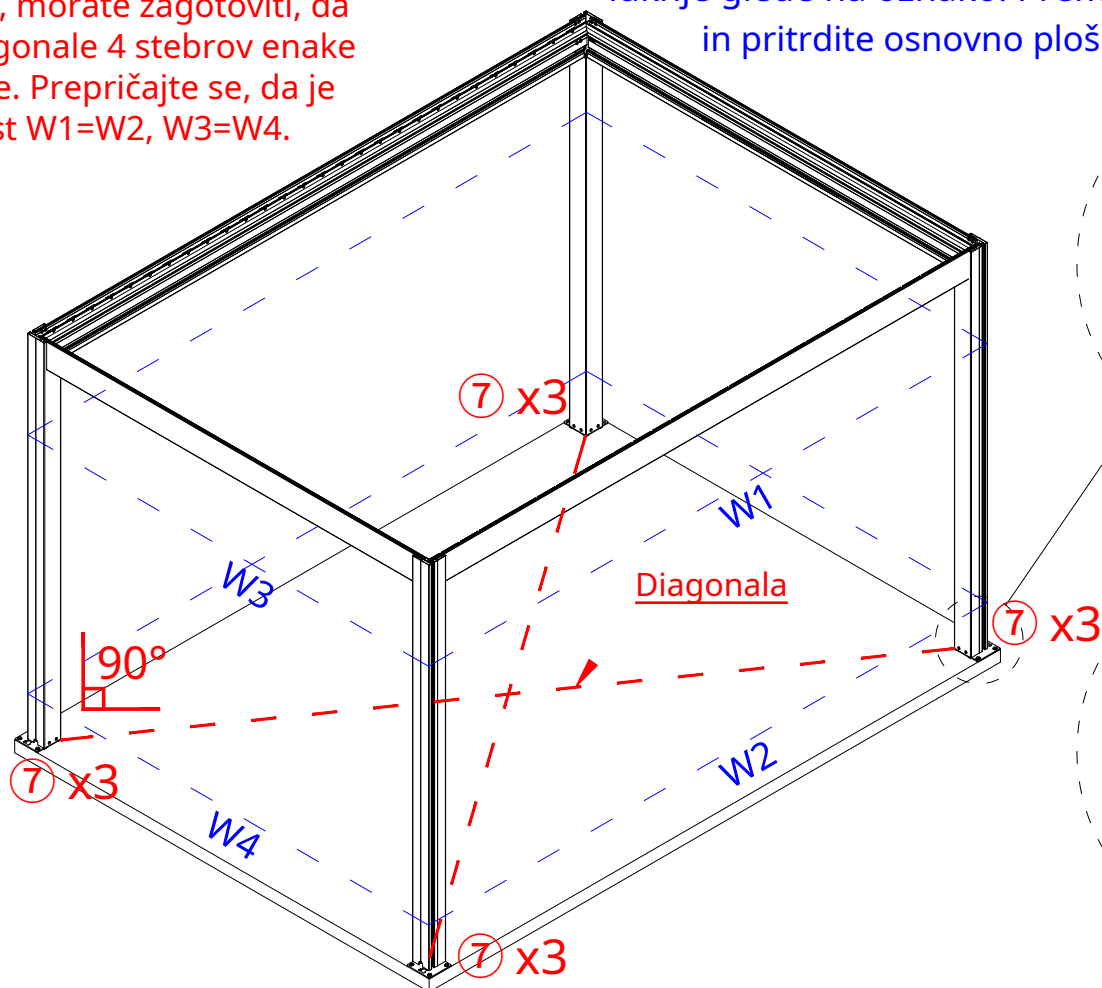

Uporabnik je dolžan zagotoviti, da je pergola pritrjena. Proizvajalec ne odgovarja za škodo, ki jo na pergoli (ali njeni opremi) povzročijo naravne nesreče ali posebni dogodki. Vsako pergolo, ki ni pritrjena, lahko odnese in povzroči škodo, pri čemer ta odgovornost ne bo pripisana proizvajalcu. Pergolo redno preverjajte, da zagotovite, da ostaja stabilna in trdno pritrjena na tla. Garancija ne krije pergole, ki se loči od svojega položaja in povzroči ali povzroči škodo.

 LED žica

 Napajalna žica

Vodenje žic

Ko polagate žice, jih potisnite v steber iz zarez na zgornjem koncu stebra, nato povlecite žice do izhodne luknje, nato izvlecite žice iz vtičnice in končno pojdite ven iz luknje na dnu delovnega mesta.

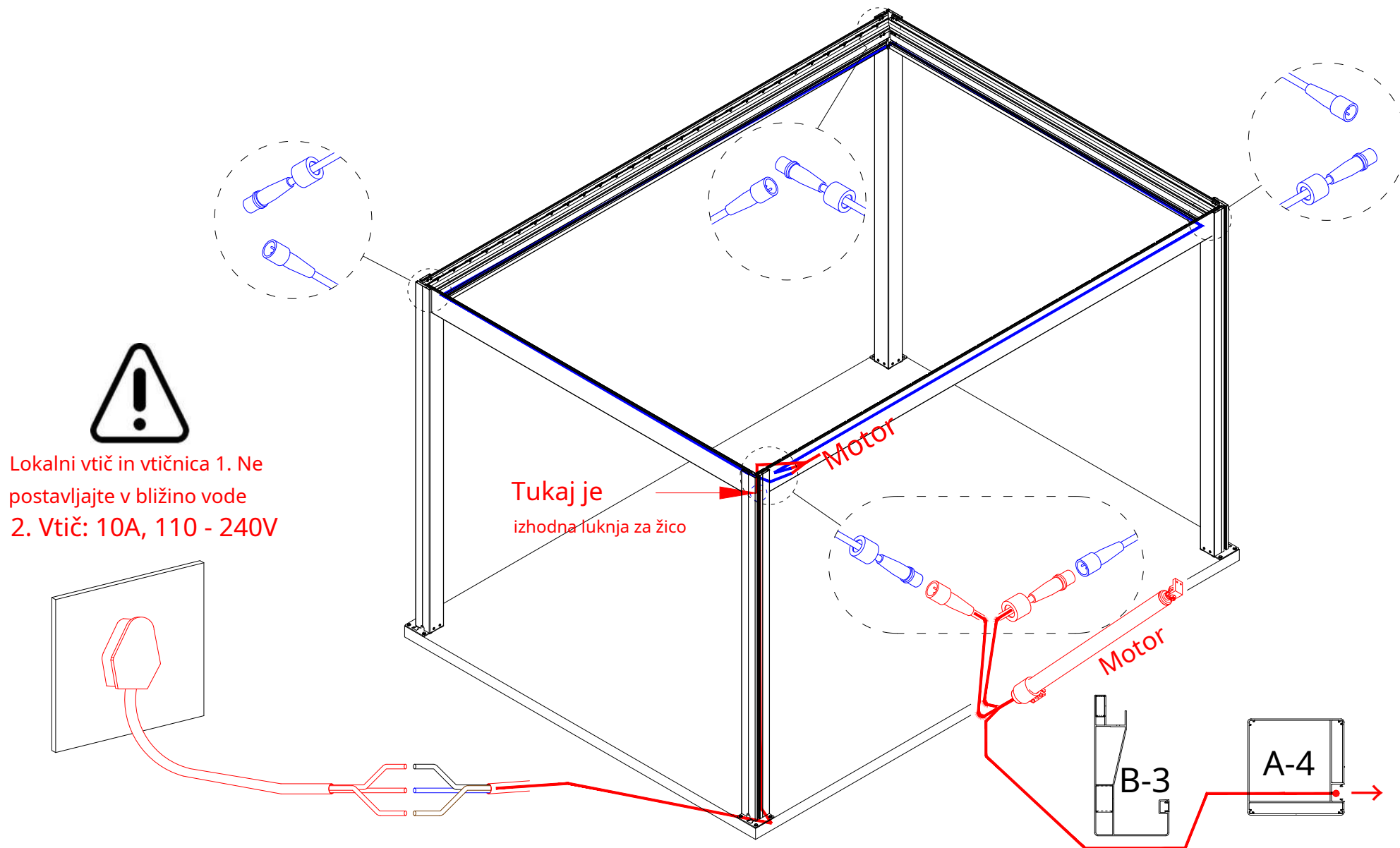



Opomba: Prosimo, sledite korakom za pravilno povezavo žice, sicer bo motor pokvarjen.

 Vtič ni priložen

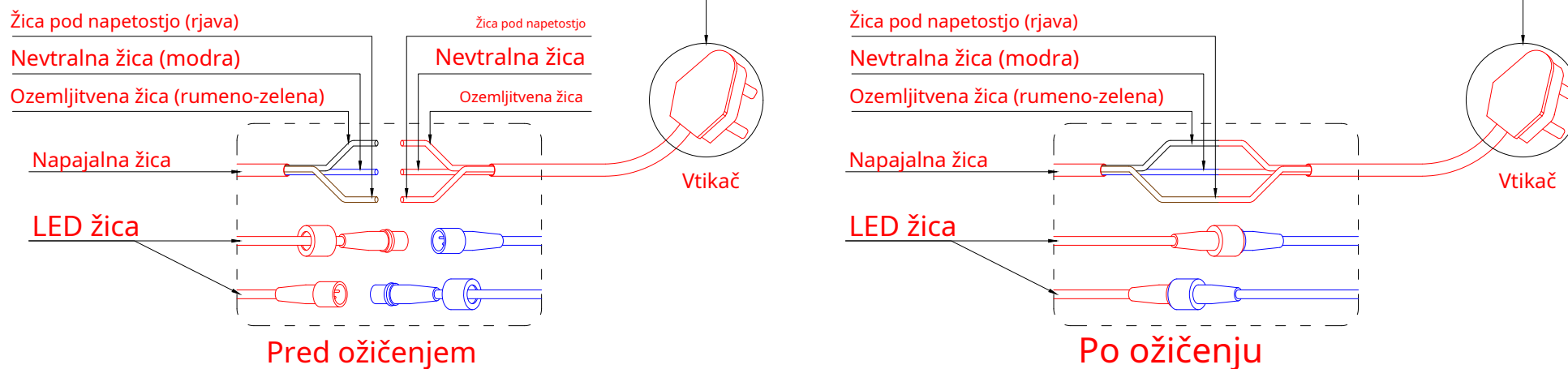

8

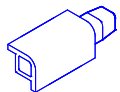

x 4

Pritrdite kotni podaljšek stebra

1) Kot je prikazano, prosimo potisnite podaljšek kota stebra v zgornji del kota stebra.

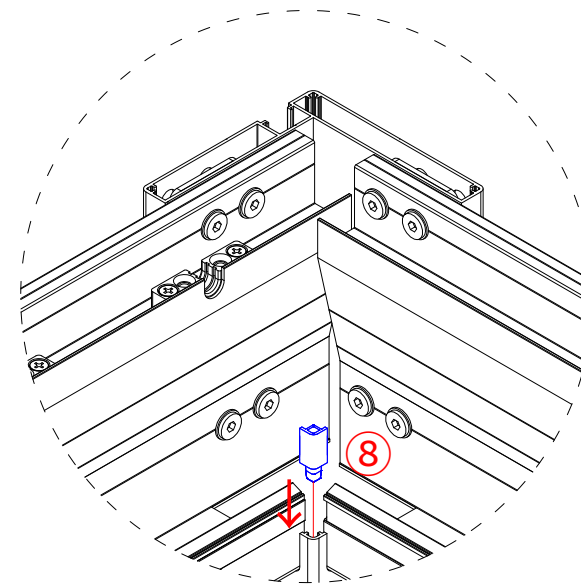
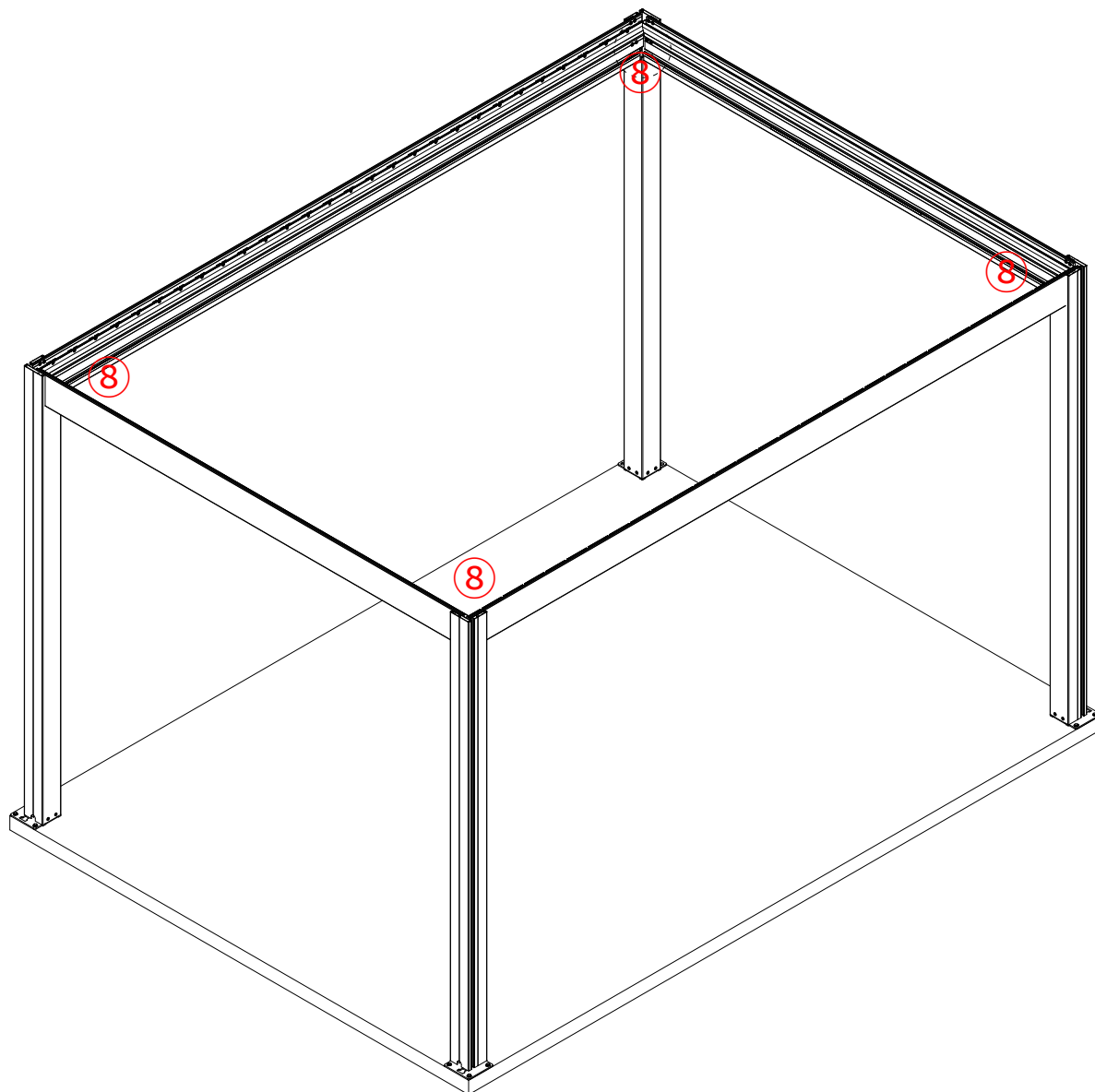

Korak 1

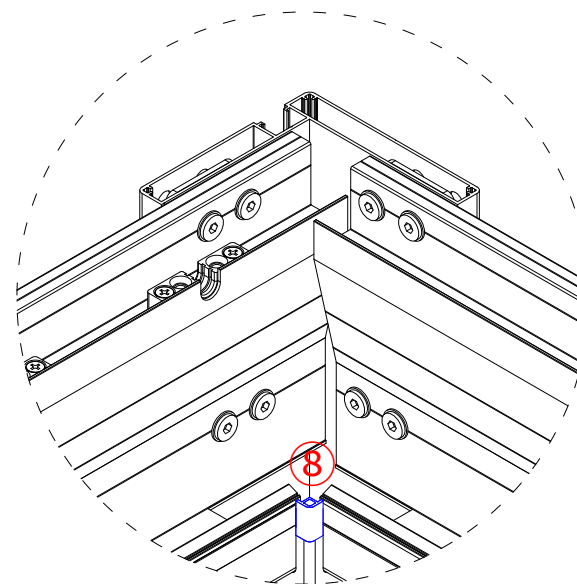

2. korak

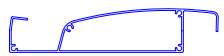
C-1**x 1****Namestitev Louvra**

- 1) Kot je prikazano, se motorna povezovalna rešetka C-1 zaskoči neposredno v utor.
- 2) Priključite nosilec roke motorja na končni pokrov motorne priključne rešetke C-1.

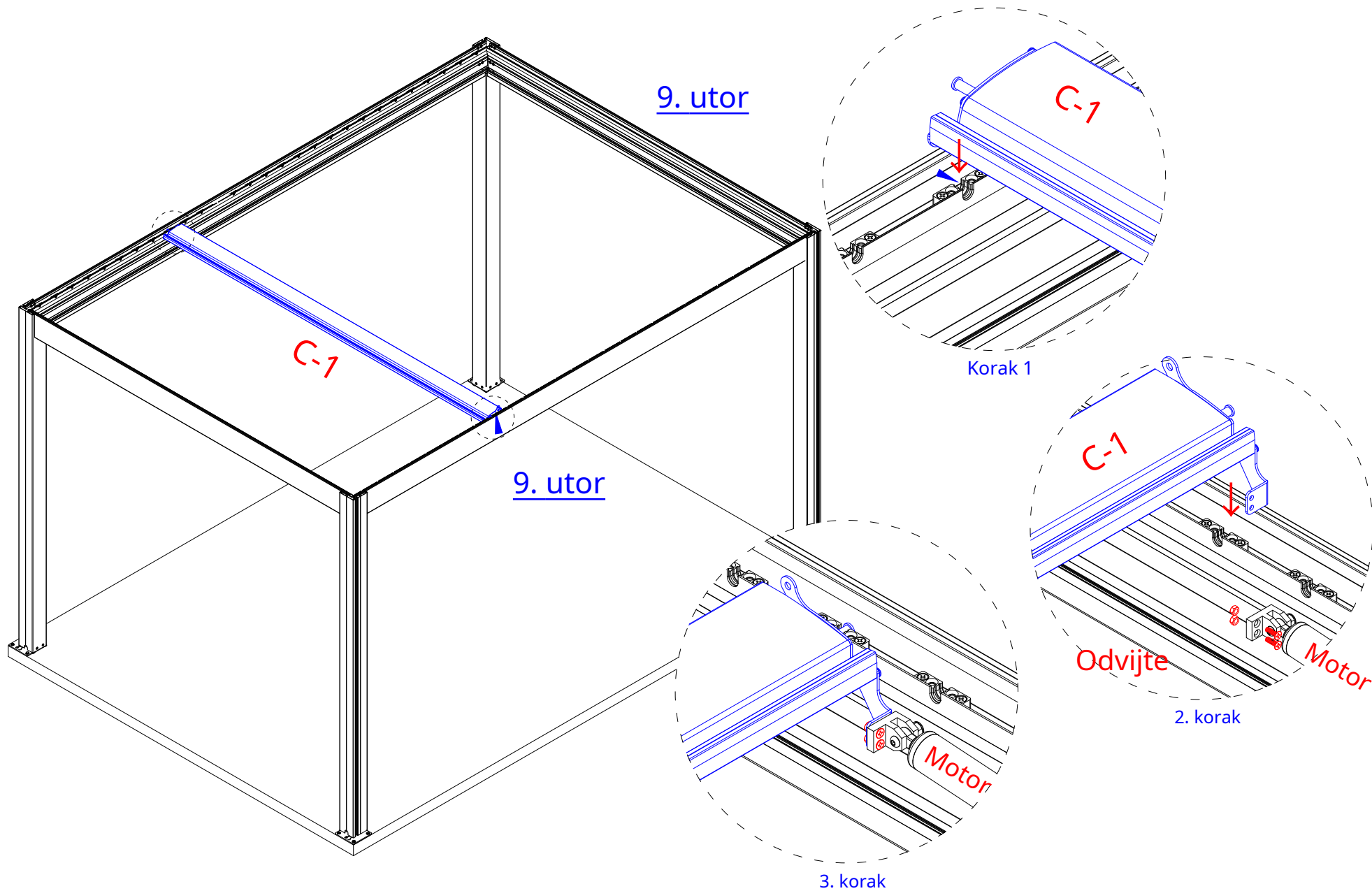

C-2 x 27



Namestitev Louvra

3) Kot je prikazano, se rešetka C-2 zaskoči neposredno v utor.

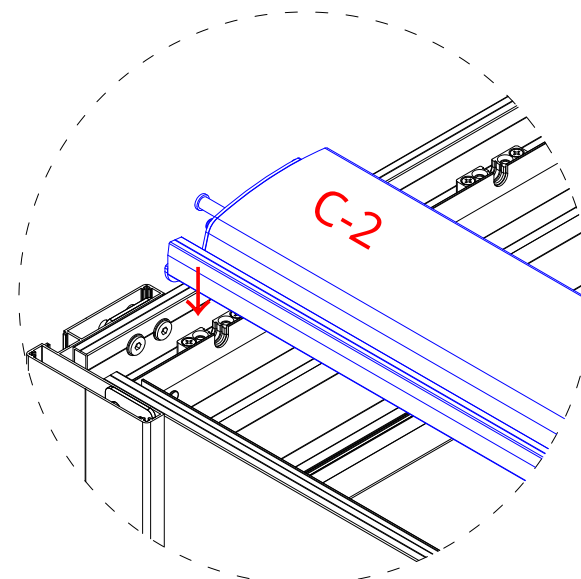
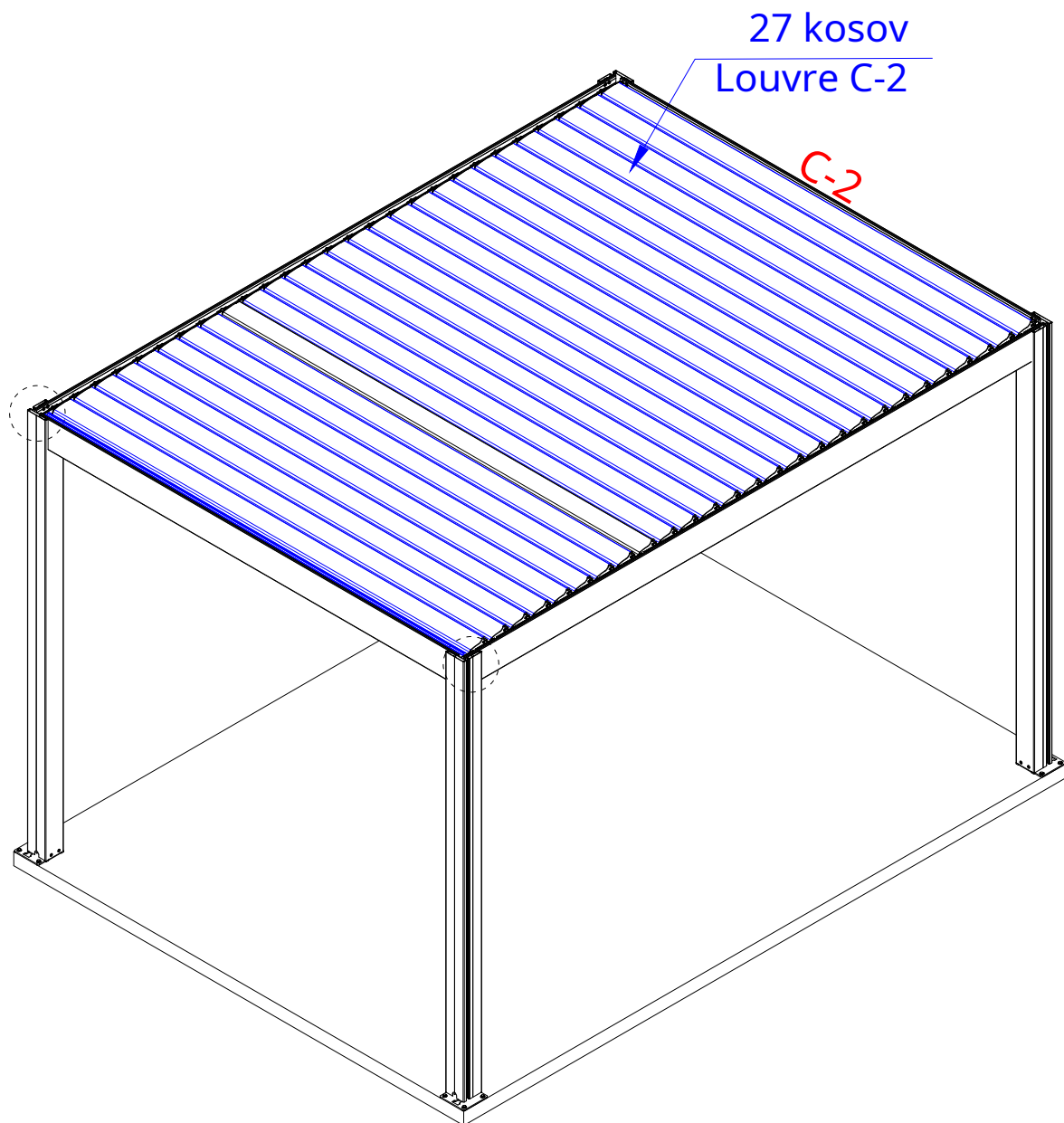

Korak 1

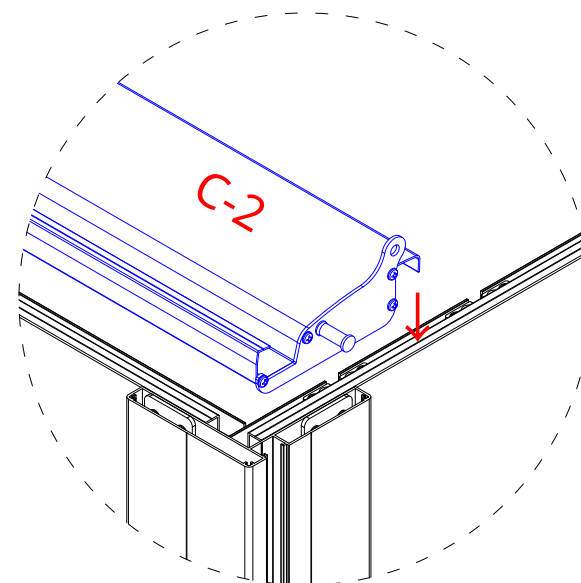

2. korak

9

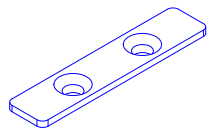

x 56

10



x 112

Namestitev Louvra

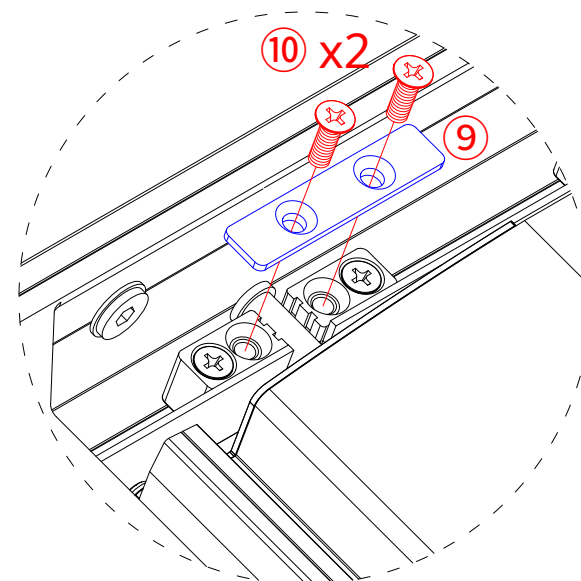
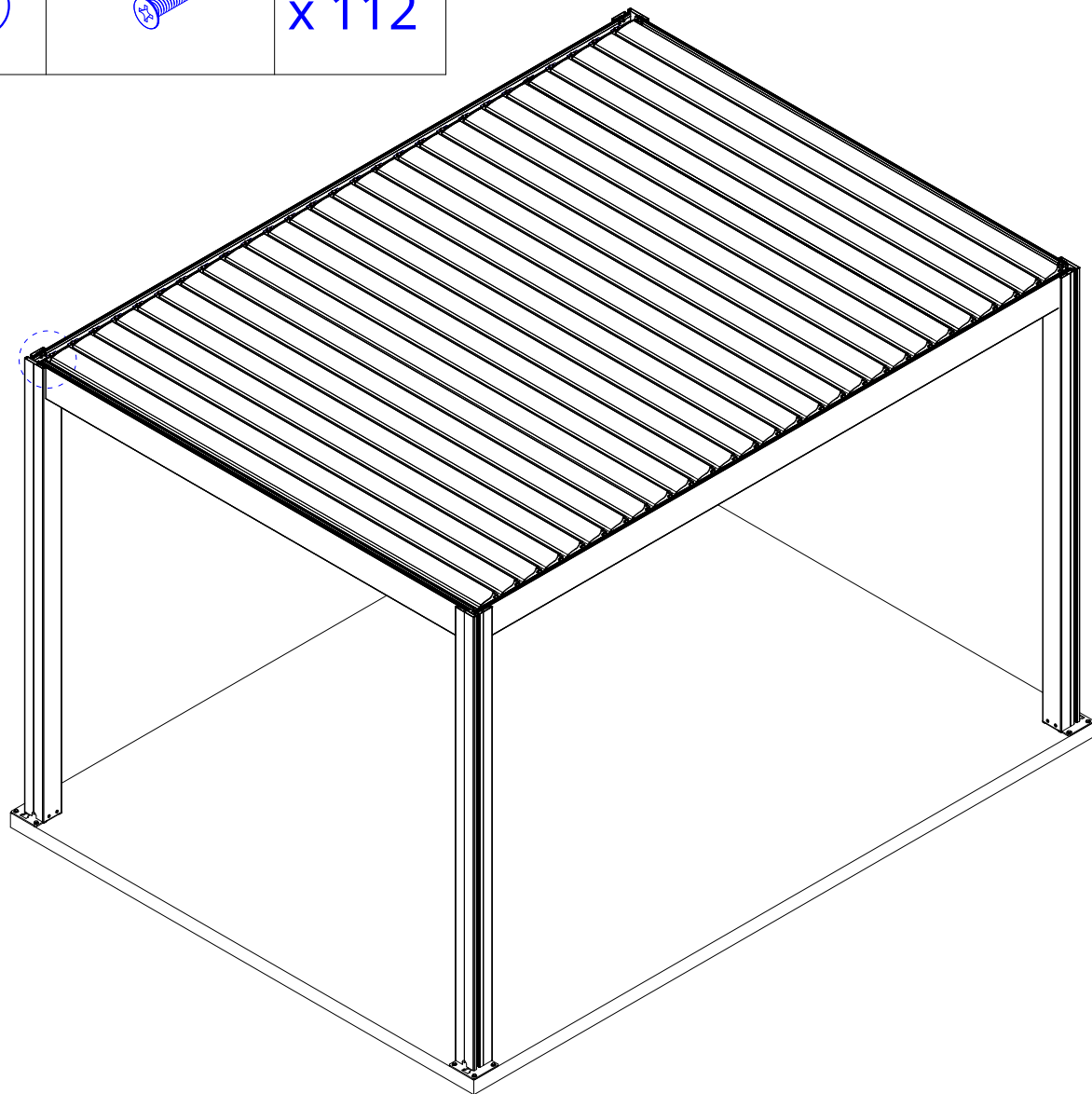

4) Kot je prikazano, pritrjena kapica držala gredi⁹ vklopljenodržalo grediz M5*16 vgrezni vijak¹⁰.

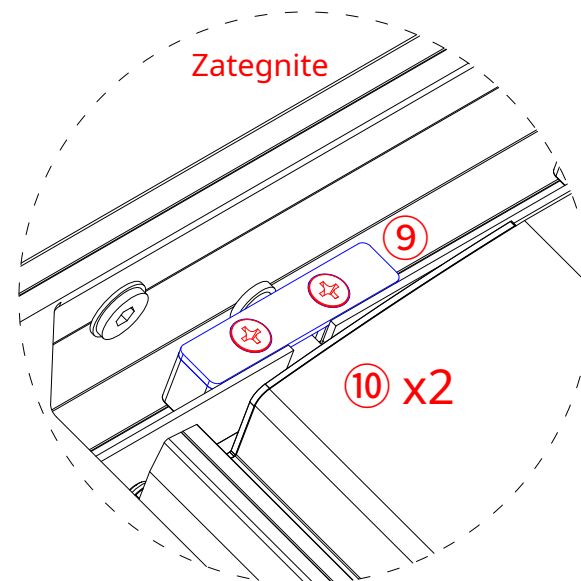

Korak 1



2. korak

D		x 1
11		x 28

Namestitev Louvra

5) Kot je prikazano, uporabite šestrobi vijak M6*5¹¹ skozi luknjo (na krmilni palici D), nato pritrdite na rešetko.

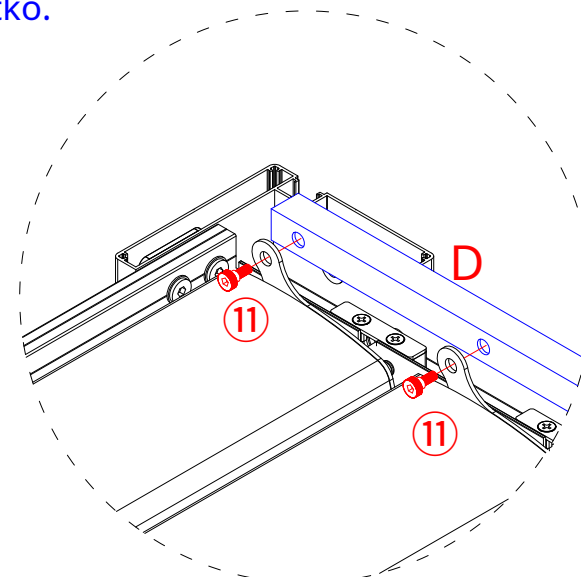
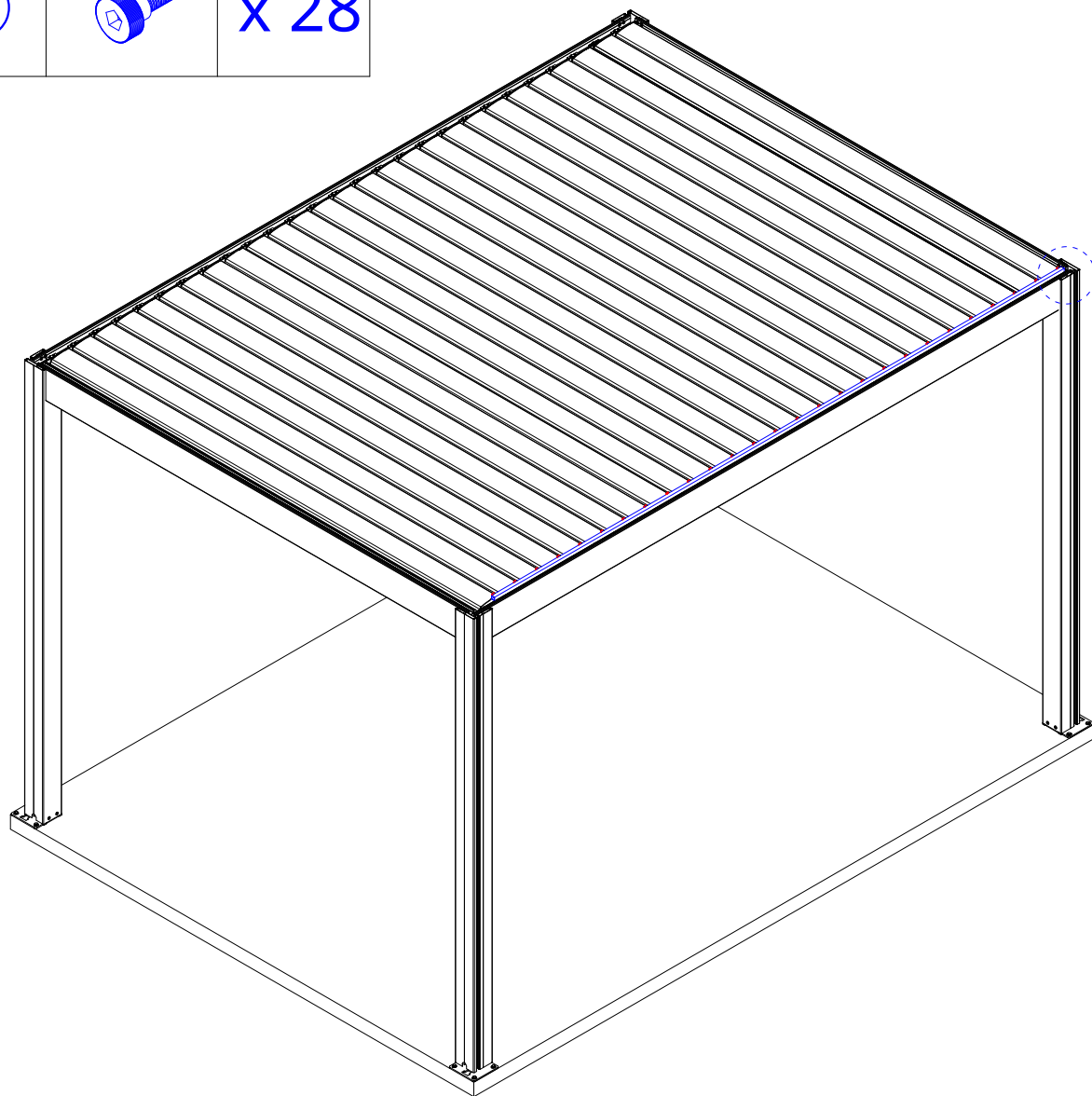

Korak 1

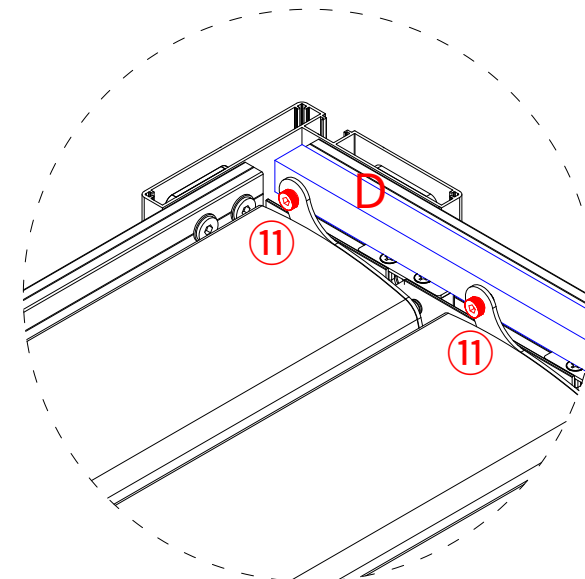

2. korak

E**x 4**

Popravite pokrov T-slota

1) Kot je prikazano, vstavite pokrov T-reže E v utor droga.

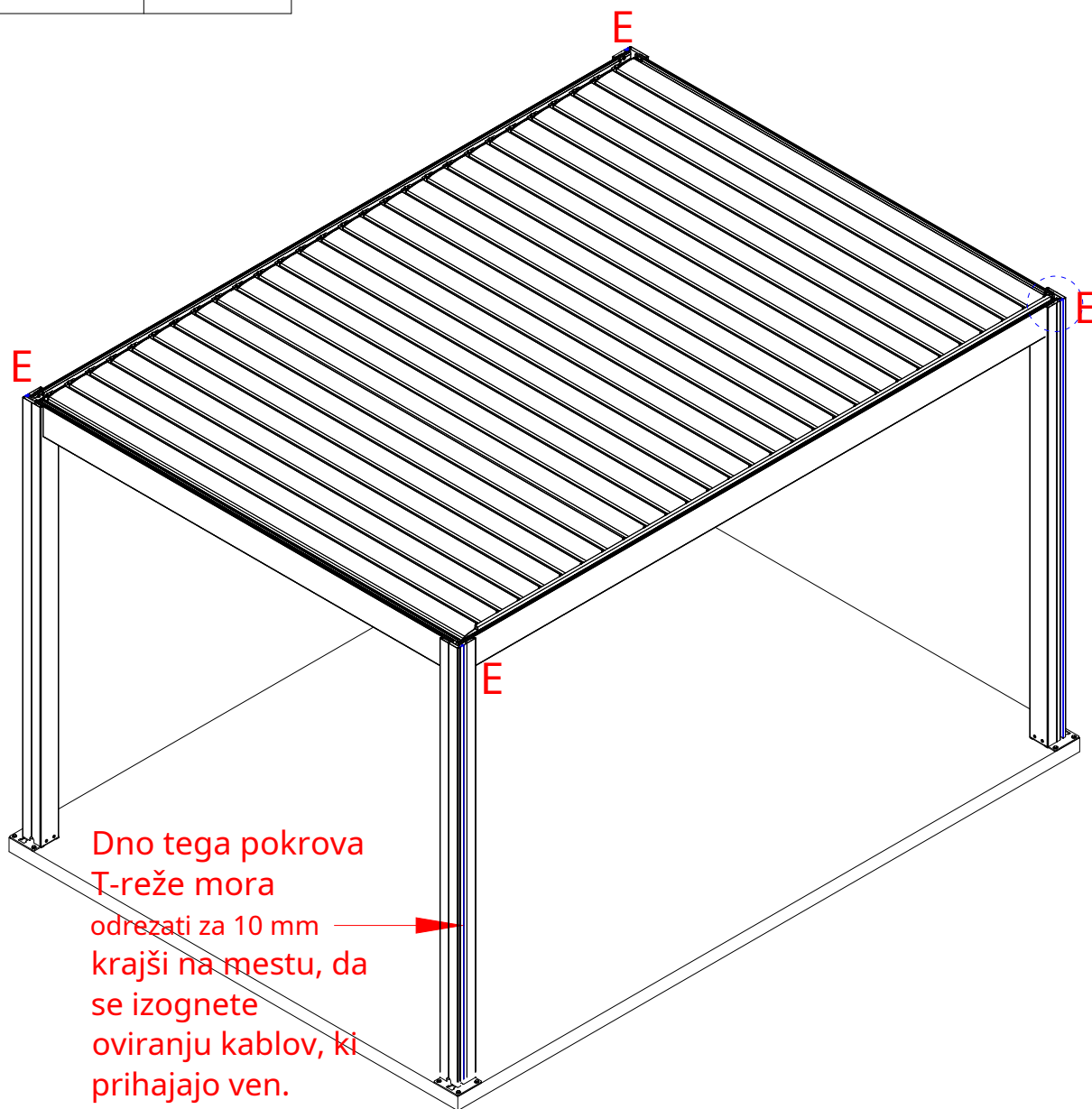

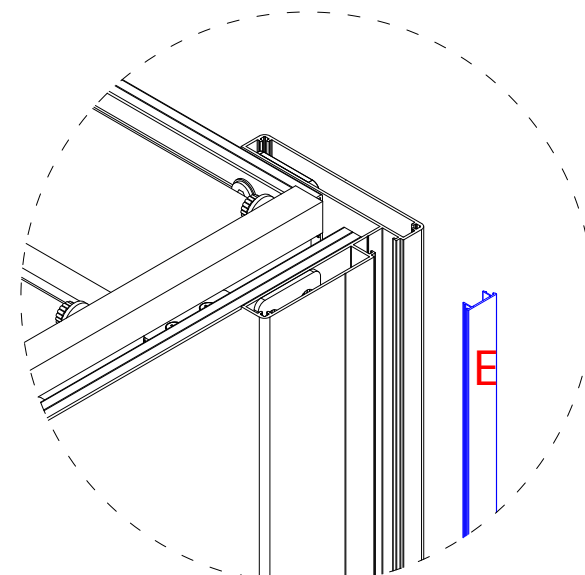

Dno tega pokrova T-reže mora odrezati za 10 mm krajši na mestu, da se izognete oviranju kablov, ki prihajajo ven.

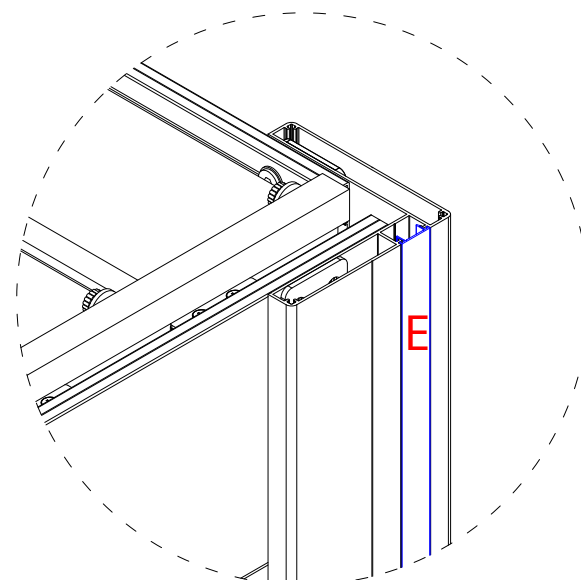

Korak 1

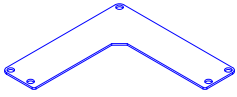

2. korak

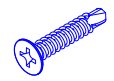
12		x 4
13		x 12
15		x 8

Popravite zgornji pokrov stebra

2) Kot je prikazano, namestite zaključno ploščo v obliki črke L¹² na vrhu stebra in ga nato pritrdite s 3 samoreznimi vijaki 4,2*16¹³ in 2 vijaka s svedom 4,2*19¹⁵.

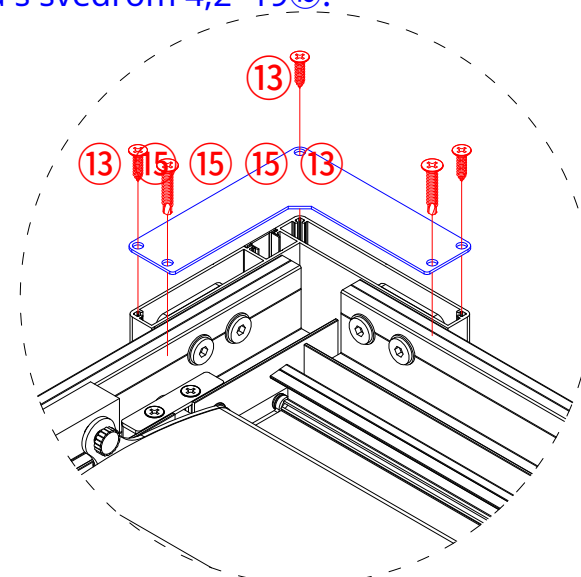
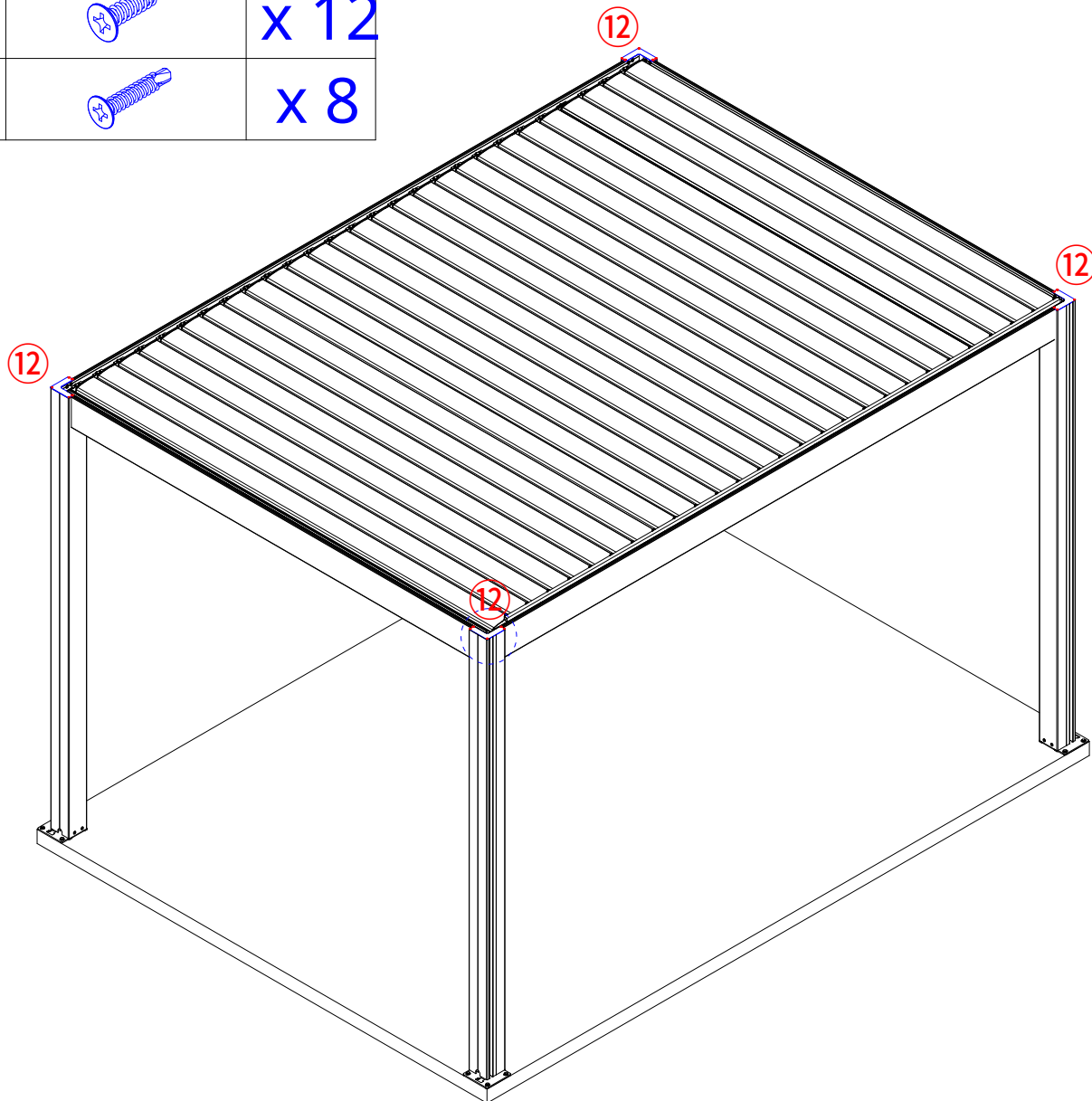

Korak 1

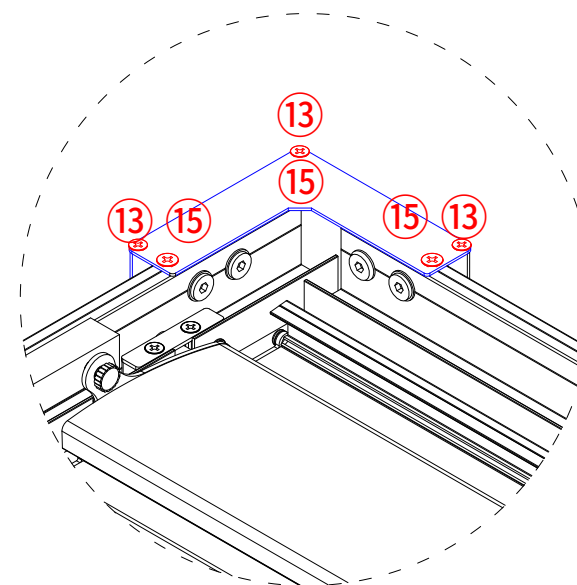

2. korak

2

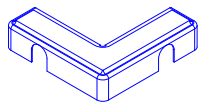

x 4

Namestitev pokrova osnovne plošče

1) Kot je prikazano, mora biti zareza v obliki črke U na pokrovu osnovne plošče usmerjena v isto smer kot odtočna odprtina. Pokrov osnovne plošče na drogu z dodatno iztočno zarezo.

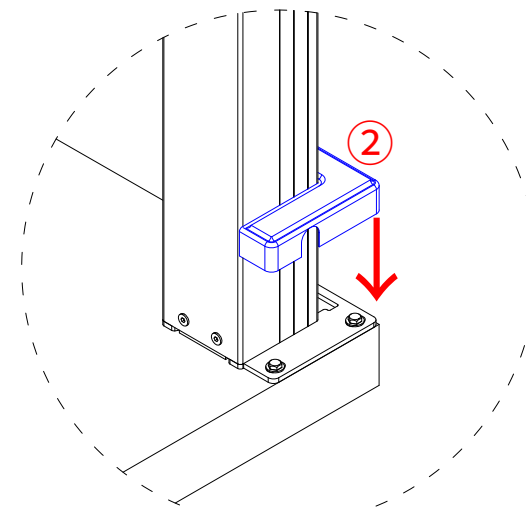
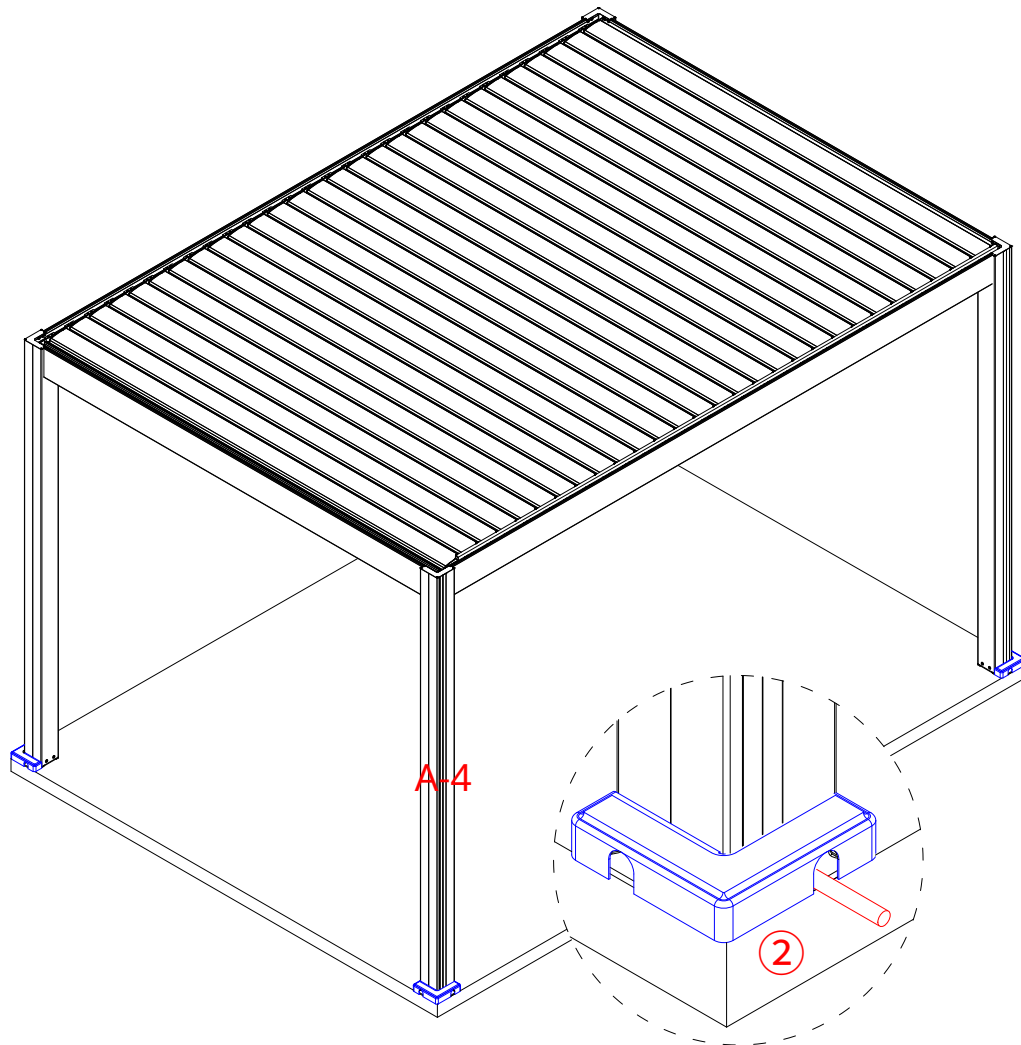

Korak 1

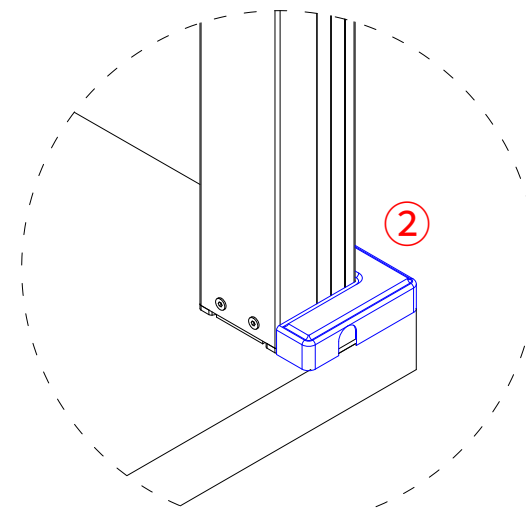

2. korak

Če daljinski upravljalnik in sprejemnik ne moreta upravljati motorja, sledite spodnjim korakom za ponovno programiranje.

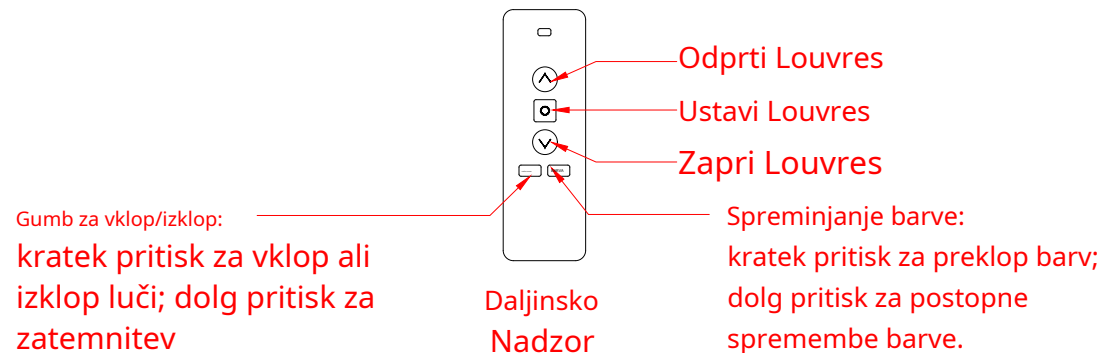

Koraki za seznanjanje:

1

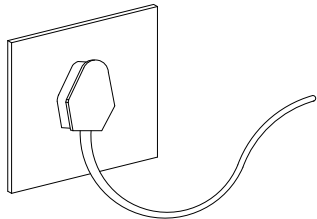

Prosimo, da izklopite napajanje za 15 sekund in ga nato ponovno priključite začnite naslednje korake v 30 sekundah.

2



Odprite zadnji pokrov daljinskega upravljalnika/sprejemnika, pritisnite in držite Gumb U2 za več kot 7 sekund.

3

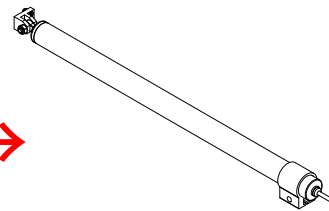

Ko motor še naprej ustvarja a "bipbipbip" zvok.

4

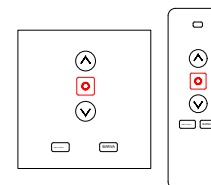

Pritisnite in držite gumb za zaustavitev daljinskega upravljalnika/sprejemnika znova držite več kot 2 sekundi. Ko "bipbipbip" zvok motorja izgine, to pomeni, da je bil daljinski upravljalnik/sprejemnik uspešno seznanjen.

Koraki za spreminjanje smeri:

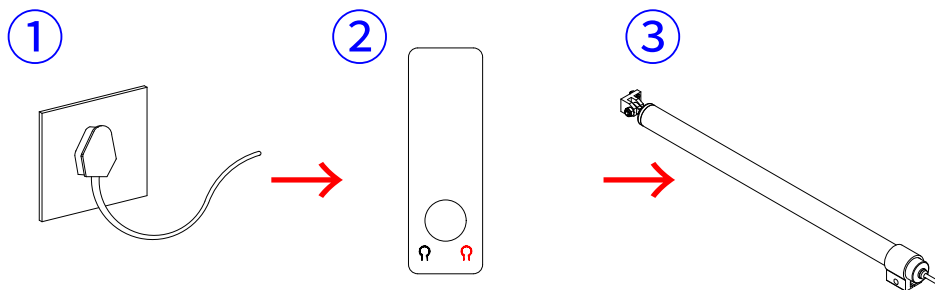

Prosimo, izklopite napajanje za 15 sekund in ga nato ponovno priklopite moč, torej prosim začnite naslednje korake znotraj 30 sekund.

Odprite zadnji pokrov daljinskega upravljalnika/sprejemnika, pritisnite in držite **Gumb U2** za več kot 7 sekund.

Ko motor še naprej ustvarja a "bipbipbip"zvok.

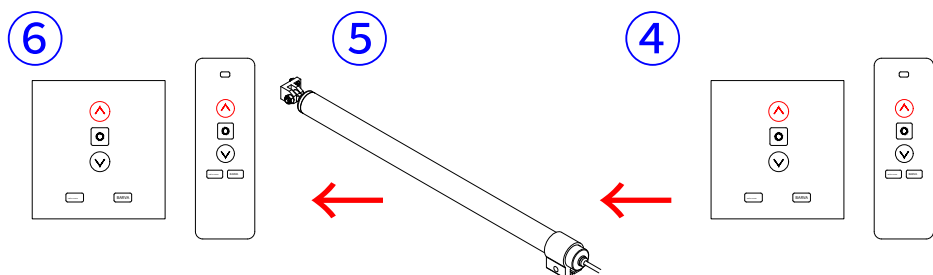

Pritisnite in držite **gumb gor** daljinskega upravljalnika za več kot 2 sekundi.

Motor naredi a "bipbipbip"spet zvok

Pritisnite in držite **gumb gorod** daljinca/sprejemnika za več kot 2 sekundi.

Koraki brisanja parov:

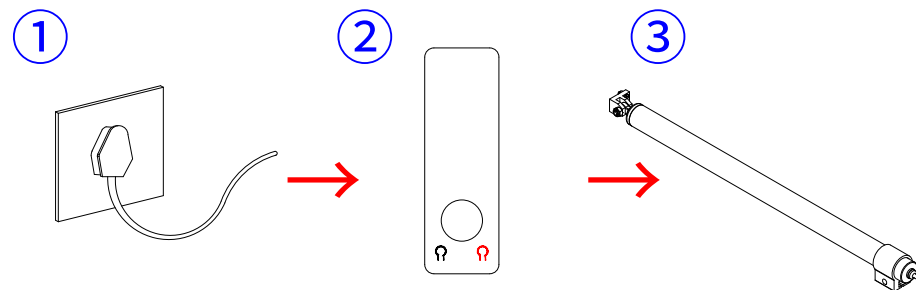

Prosimo, izklopite napajanje za 15 sekund in ga nato ponovno priklopite moč, torej prosim začnite naslednje korake znotraj 30 sekund.

Odprite zadnji pokrov daljinskega upravljalnika/sprejemnika, pritisnite in držite **Gumb U2** za več kot 7 sekund.

Ko motor še naprej ustvarja a "bipbipbip"zvok.

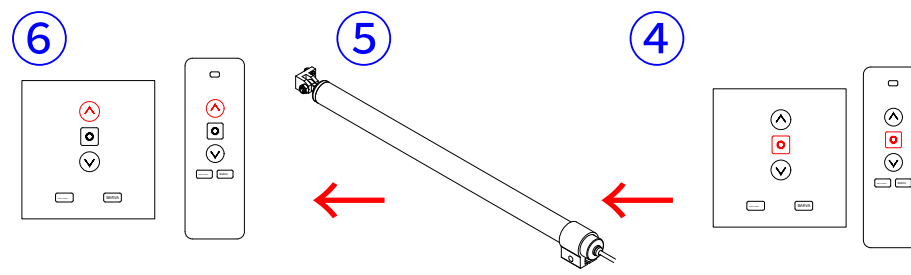

Pritisnite in držite **gumb gor** daljinca/sprejemnika za več kot 2 sekundi. Izbršite seznanjanje uspešno.

Motor naredi a "bipbipbip"spet zvok

Pritisnite in držite **gumb zaustavitev** daljinca/sprejemnika za več kot 2 sekundi.

Skrb za vašo pergolo

Konstruktivske površine, premazane s termoreaktivnimi praškastimi premazi, je treba očistiti enkrat letno, da ohranijo prvotni estetski videz.

Termoreaktivni praški so občutljivi na:

- Fizično trenje, močan udarec, iztiskanje, kemikalije, vključno z alkalnim in kislim topilom.
- Naravni elementi, kot so veter, dež, sneg in dolgotrajna sončna svetloba. Zunanost pergole se lahko sčasoma pokvari in tega garancija ne krije.

Čiščenje vaše pergole

- Ne uporabljajte čistilne gobe, kremnega čistila, abrazivne gobe, krogle iz železne žice ali barvnih krp.
- Priporočeno: mehka goba, mehka krpa brez peska, bombažna volna, bombaž ali netkani papir (samo bel).
- Ne uporabljajte jedkih izdelkov, kot so kislila ali alkalna čistila. Priporočljivo je, da ga operete z vodo z nevtralnimi pH in nato obrišete s krpo, da ostane suh.
- Pri čiščenju z visokotlačno opremo je treba upoštevati enake varnostne ukrepe kot pri čiščenju karoserije avtomobila: upoštevati je treba razdaljo, vrsto šobe, temperaturo in tlak vode.

Uporabite opomnik

- Po končani namestitvi preverite, ali so vijaki priviti. Ne pozabite preveriti vijakov vsaj enkrat na leto.
- **V primeru napovedanega sneženja, toče ali močnega vetra s hitrostjo nad 80 km/h je priporočljivo odpreti lamele žaluzije. Ne uporabljajte rezil v primeru zmrzali ali snega. Ko je snega v izobilju, odstranite rezila s pergole.**
- Redno preverjajte pogoje tesnjenja, da zagotovite, da tesnila ali drugi deli ne puščajo.
- Redno čistite smeti, kot je odpadlo listje na pergoli, da preprečite zamašitev odtoka.
- Omejitve uporabe: Vodotesni sistemi, čeprav učinkoviti, niso zasnovani tako, da zagotavljajo popolno vodotesnost. Močan dež in močan veter lahko poškodujeta pergolo. Morebitne nastale škode ne krije garancija.

NÁVOD NA POUŽÍVANIE

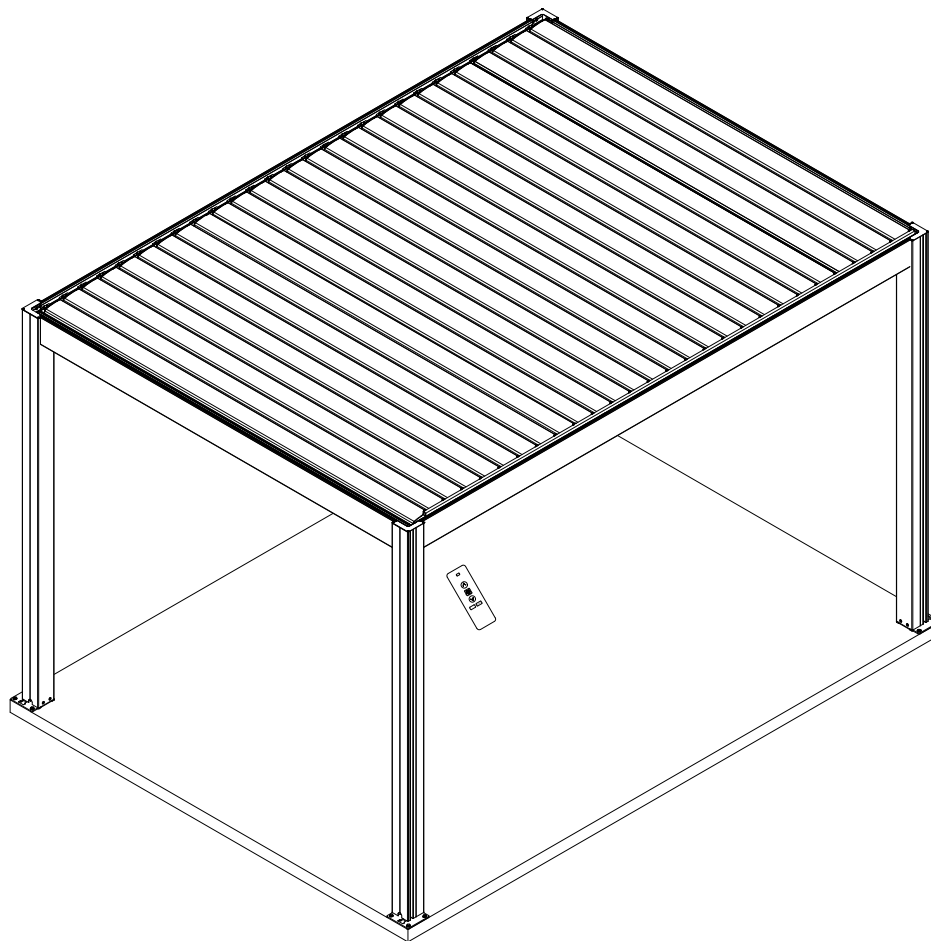

OTHER LANGUAGES

Pergola 4x2,86m

Pred prvým použitím pergoly si prečítajte tento návod.
Uschovajte si tento návod pre budúce použitie.

Pergola

Otvorenie: Elektrické

Veľkosť: 295,3(Dĺžka)x 409(šírka) -cm

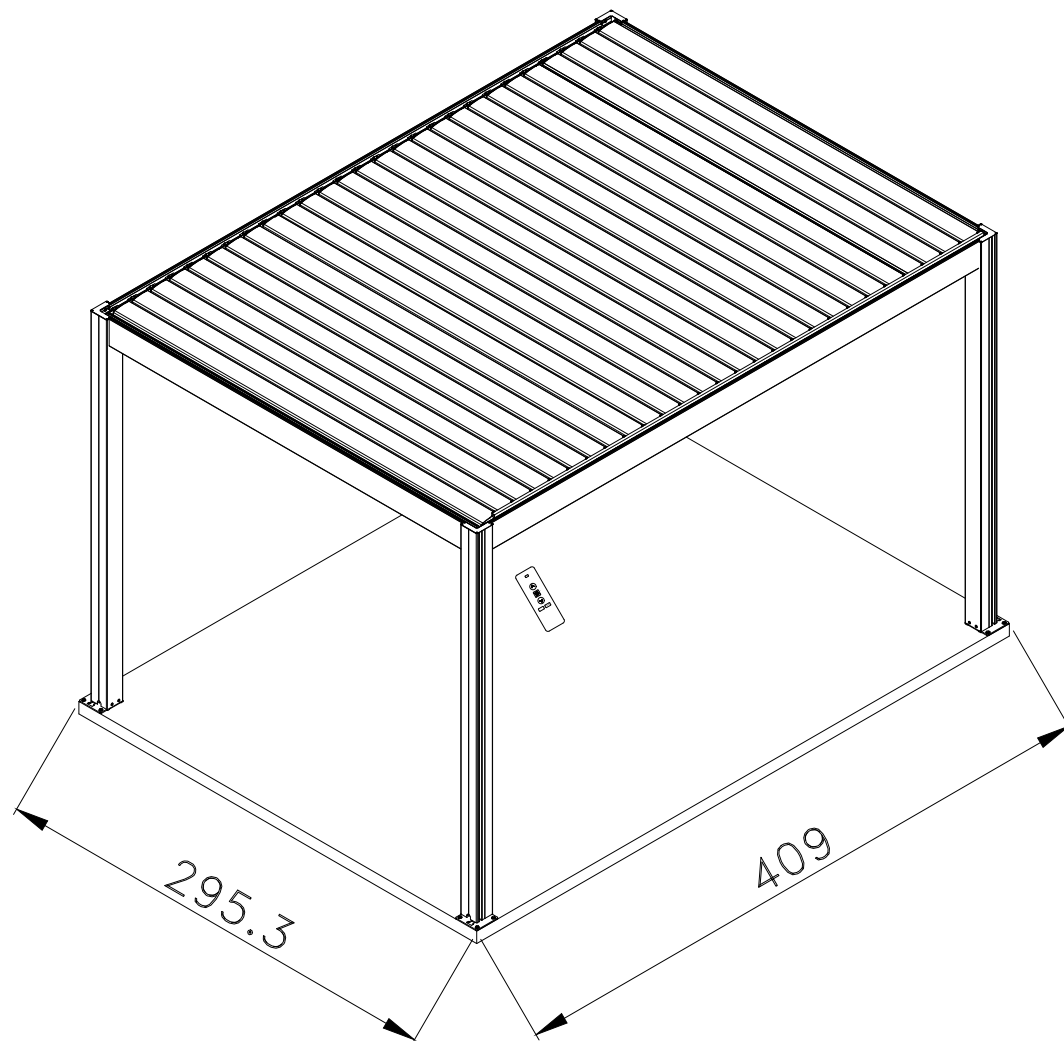

Poznámky k inštalácii:

1. Inštalácia vyžaduje minimálne troch ľudí: jedného na meranie a označovanie, jedného na inštaláciu a jedného ako asistenta.
2. Dodávajú sa iba upevňovacie prvky na betónovú podlahu. V prípade, že na zemi nie je betónová doska, odporúča sa urobiť betónové dosky pri každom stípe. Betónová doska by mala byť min

500 x 500 x 500 mm.

3. Po zložení rámu pergoly použite štvorec, vodováhu a pravítko na meranie úrovne produktu a uhlopriečky, aby ste zaistili veľkosť pergoly. Podklady musia byť presne rovné bez tolerancie.
4. Pergolu je potrebné priskrutkovať k podlahe. Neberieme žiadne zodpovednosť, ak dlaždice prasknú počas vŕtania skrutiek.
5. Vyžaduje sa elektrické náradie: uistite sa, že správne funguje a dodržiavajte bezpečnostné pokyny.
6. Buďte opatrní pri používaní ostrých nástrojov.
7. Noste ochranný odev vrátane bezpečnostných okuliarov, prilieb a rukavíc.
8. Nelezte ani nestojte na streche.

Bezpečnostné varovanie

- . Pri montáži sa dôrazne odporúča nosiť rukavice.
- . Pergolu neinštalujte počas zlých poveternostných podmienok, ako je vietor alebo dážď.
- . Nedotýkajte sa žiadnych drôtov s hliníkovými profilmi.
- . Pri montáži pergoly vždy noste ochrannú obuv a okuliare.
- . Všetky plastové vrecká uchovávajte mimo dosahu detí.
- . Stĺpik pergoly musí byť umiestnený a upevnený na rovnom povrchu.
- . Počas montážnej fázy sa o stĺp neopierajte.
- . Počas montážnej fázy nedovoľte deťom priblížiť sa k scéne.
- . Nebuďte v blízkosti pergoly počas búrky alebo tajfúnu.
- . Nepokúšajte sa vyliezť na pergolu pod vplyvom alkoholu alebo drog.
- . Pri používaní rebríkov alebo podobného náradia a elektrického náradia počas montážnej fázy bezpodmienečne dodržujte bezpečnostné odporúčania výrobcu.
- . Akékoľvek horúce náradie, ako napríklad elektrická vŕtačka, nemôže byť v kontakte s profilom pergoly.
- . Pred umiestnením stĺpa sa uistite, že pod zemou nie sú skryté žiadne káble alebo iné káble.

Všeobecné rady

- . Táto pergola má niekoľko komponentov a jej zloženie trvá minimálne 90 minút. Pergola by nemala byť umiestnená pod stromom.
- . Ak pripájate stĺp priamo k cementu alebo podobnej základni, použite predierované otvory na dodanej základni.
- . Pred montážou skontrolujte počet profilov a kovaní a použite ich podľa zoznamu profilových kovaní pre jednoduchú montáž.
- . Vložte malé kúsky, ako sú skrutky, do nádoby, aby ste predišli strate.
- . Dávajte pozor na polohu prevodu na nosníku, aby ste predišli nesprávnemu umiestneniu.
- . Pergolu pravidelne čistite lístie, sneh alebo iné predmety.

Údržba a opravy

- . Na čistenie pergoly použite jemný čistiaci prostriedok a opláchnite ju vodou. Na čistenie povrchu hliníkového profilu nepoužívajte acetón ani abrazívne čistiace prostriedky.

Záruka

- . Všeobecná záruka na zmenu farby je 5 rokov, na motor a LED osvetlenie 2 roky.

Ochranné a inštalačné nástroje

Ochranné vybavenie:

1. Prilba
2. Rukavice
3. Núdzová súprava prvej pomoci
4. Ochranné okuliare



Merací prístroj:

1. Zvinovací meter (5 metrov alebo viac)
2. Štvorcové pravítko
3. Úroveň

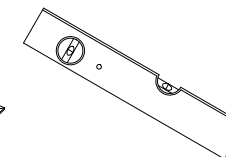
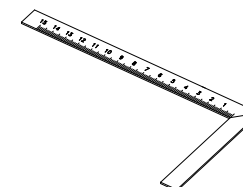
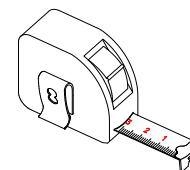





Nástroje:

1. 2 metrový rebrík (1,5 metra alebo viac)
2. 13mm imbusový kľúč
3. 17mm imbusový kľúč
4. Elektrická vŕtačka
5. Elektrický vrták (10 mm vrták)
6. Fixka alebo ceruzka
7. Gumové kladivo
8. Tesniaca a lepiaca pištoľ



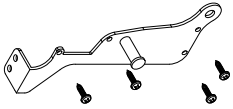
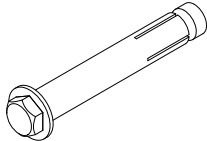
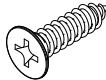
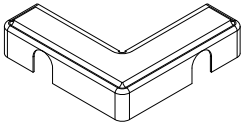
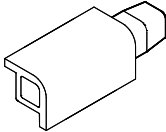
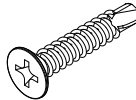
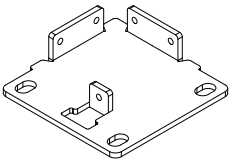
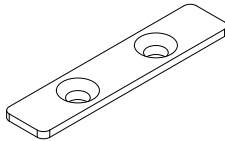
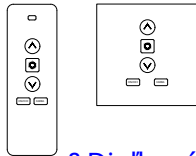
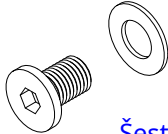

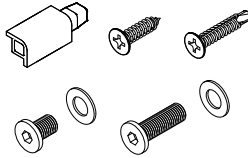
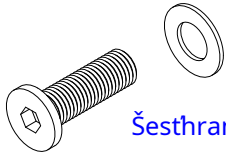

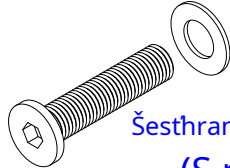
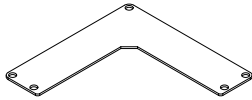

Silicon

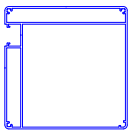
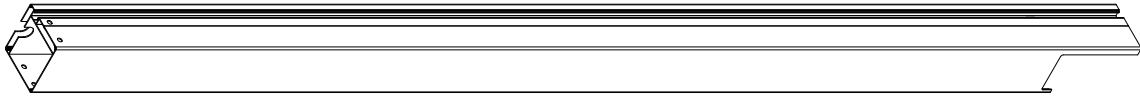
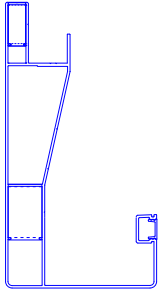
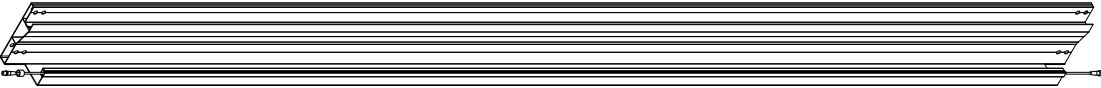
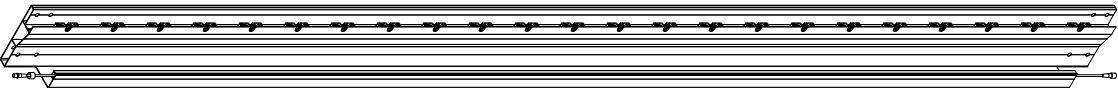
Zoznam príslušenstva a skrutiek

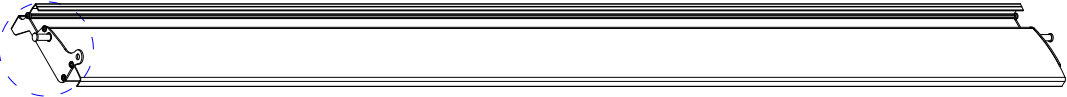
<p>①</p>	 <p>x 1 Koncovka pre Mriežka na pripojenie motora & 4 * 20 skrutky s plochou hlavou</p>	<p>⑦</p>	 <p>x 16 Rozširovacia skrutka M8*80</p>	<p>⑬</p>	 <p>x 12 Skrutka s plochou hlavou 4,2*16</p>
<p>②</p>	 <p>x 4 Kryt základnej dosky</p>	<p>⑧</p>	 <p>x 4 Roh príspevku Predlžovací kus</p>	<p>⑭</p>	 <p>x 8 4,2 * 19 vŕtacia skrutka</p>
<p>③</p>	 <p>x 4 Základná doska</p>	<p>⑨</p>	 <p>x 56 Kryt držiaka hriadeľa</p>	<p>⑮</p>	 <p>x 1 Prijímač & Diaľkové ovládanie strechy</p>
<p>④</p>	 <p>x 16 Šesthranné skrutky M8*12 (S podložkou)</p>	<p>⑩</p>	 <p>x 112 Zápusťná skrutka M5*16</p>	<p>⑯</p>	 <p>x 1 Náhradné diely</p>
<p>⑤</p>	 <p>x 16 Šesthranné skrutky M8*25 (S podložkou)</p>	<p>⑪</p>	 <p>x 28 Šesthranná skrutka M6*5</p>	<p>⑰</p>	
<p>⑥</p>	 <p>x 16 Šesthranné skrutky M8*35 (S podložkou)</p>	<p>⑫</p>	 <p>x 4 L Horný kryt stípička</p>	<p>⑱</p>	

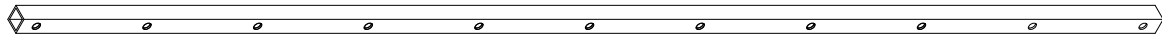
Zoznam profilov

<p>A-1 ~ A-4</p>			<p>x 4 Príspevok</p>
<p>B-2 B-4</p>			<p>x 2 Nosník a odkvap</p>
<p>B-1</p>			<p>x 1 Nosník a žlab (s držiakom hriadeľa)</p>
<p>B-3</p>			<p>x 1 Nosník a žlab (s držiakom hriadeľa) + motor</p>
<p>C-1</p>			<p>x 1 Louvre na pripojenie motora</p>
<p>C-2</p>			<p>x 27 Louvre</p>
<p>D</p>			<p>x 1 Riadiaca tyč</p>
<p>E</p>			<p>x 4 Kryt T-drážky</p>

Výkres rozloženia hliníkových profilov

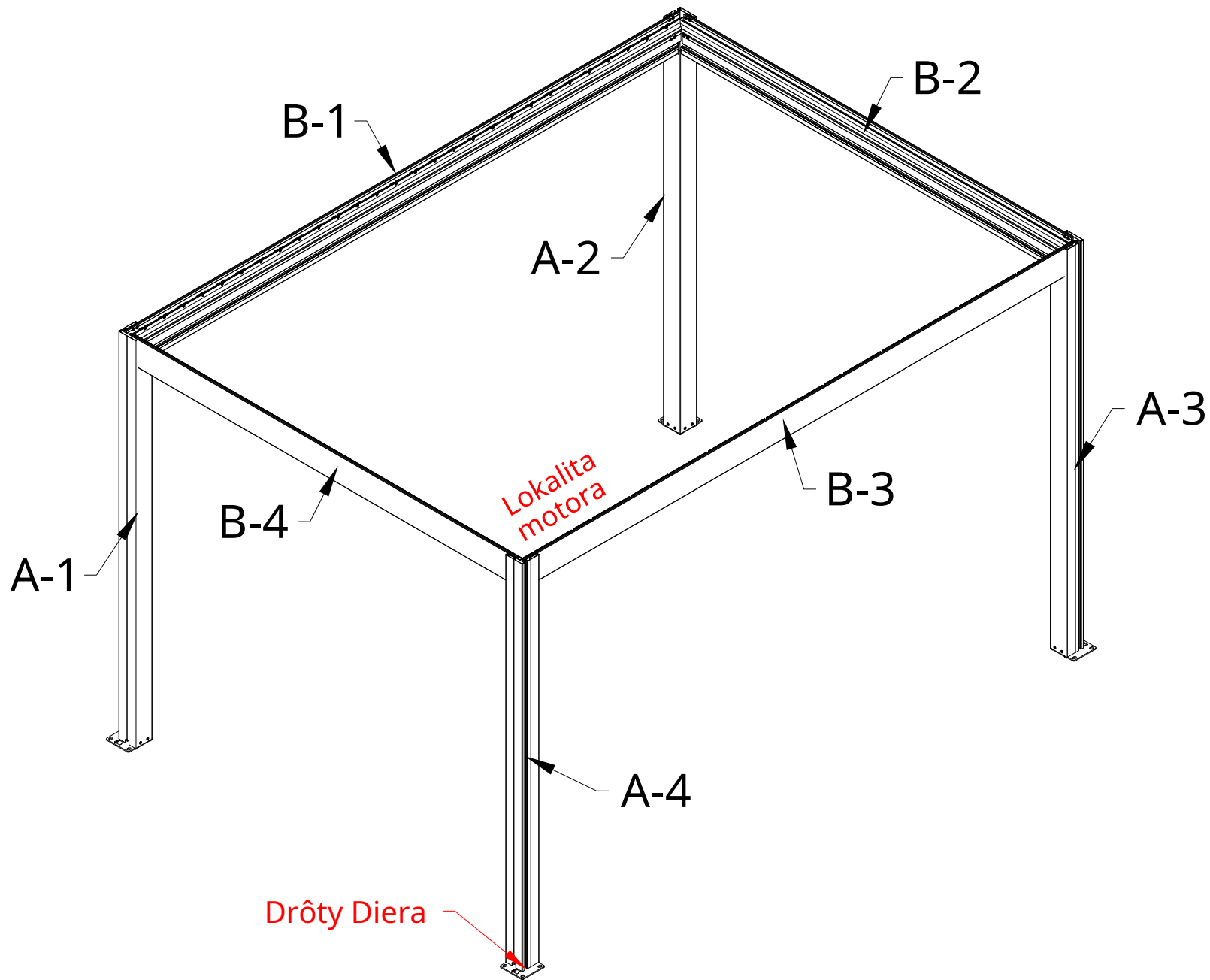

1

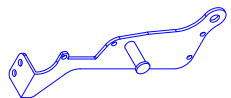

x 1



x 4

Inštalácia mriežky na pripojenie motora

- 1) Pripevnite kryt čepele na mriežku na pripojenie motora C-1 pomocou skrutiek 4*20 s plochou hlavou.

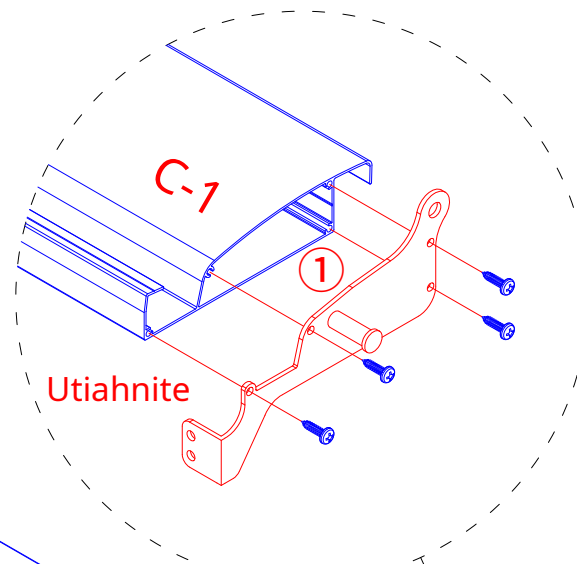

Krok 1

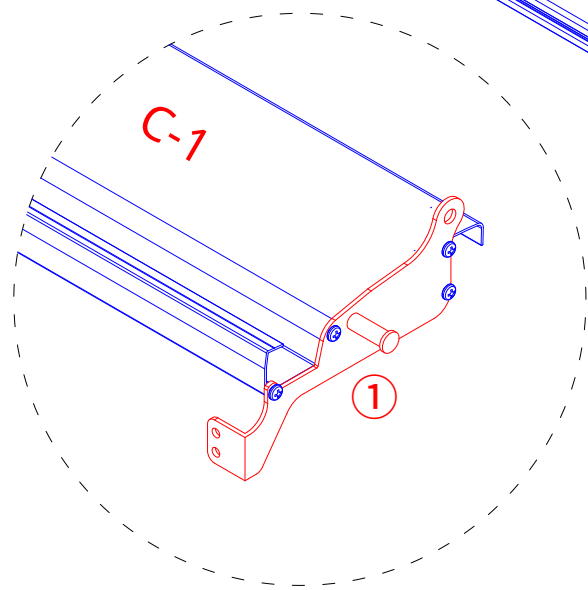

Krok 2

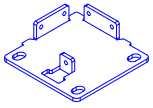
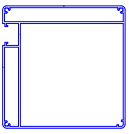
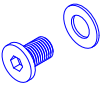

Ak je miesto inštalácie stiesnené,
kryty nožov možno nainštalovať
po inštalácii rámu.

③		x 4	A-1 ~ A-4		x 4
④		x 16			

Zostavte rámec

1) Podľa obrázka vložte kryt základnej dosky②do príspevkov, potom zarovnajte otvory v základnej doske③otvormi v stĺpikoch a zaistite základnú dosku③na stĺpiky pomocou šesťhranných skrutiek M8*12 (s podložkou)④.

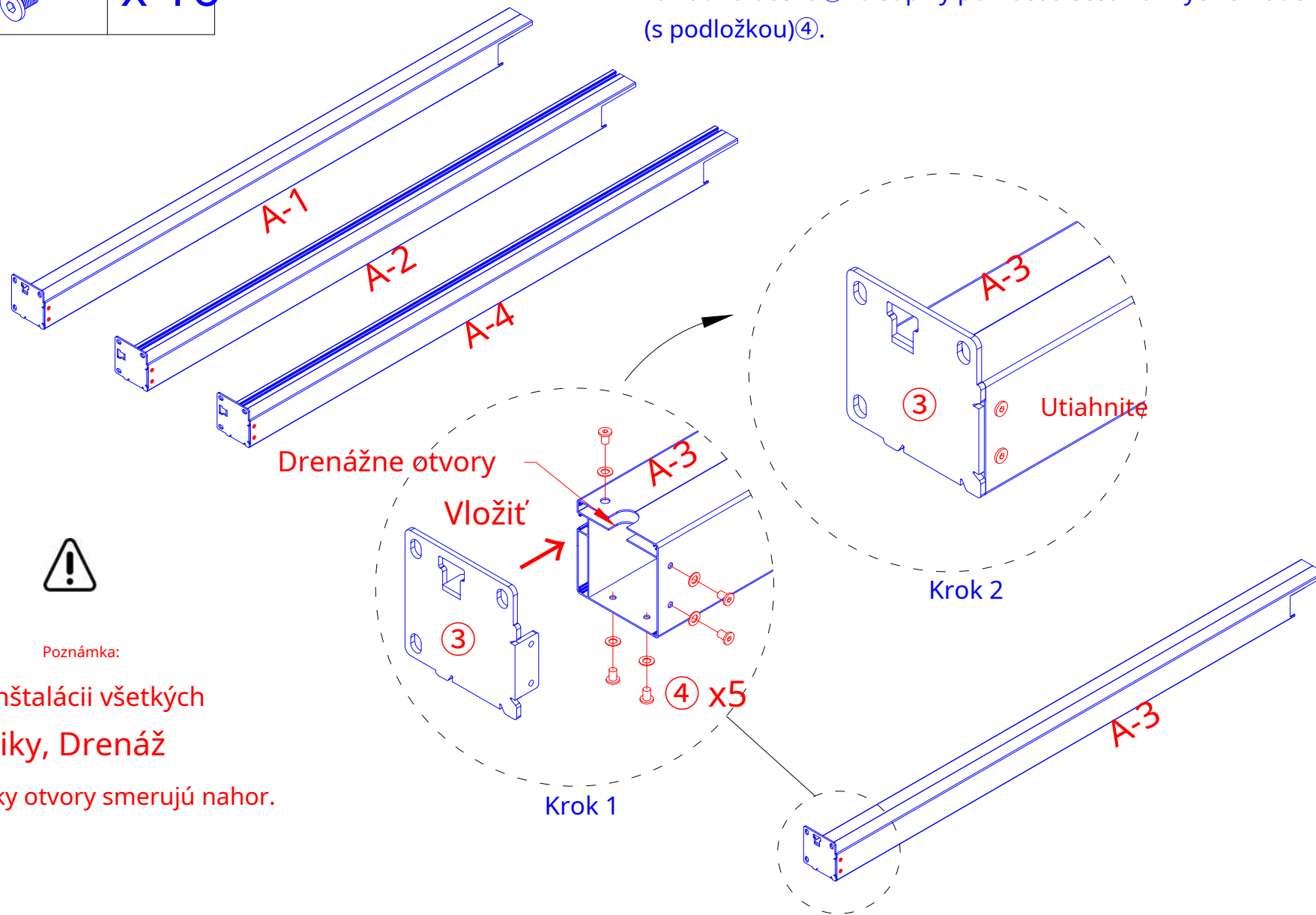

Poznámka:

Pri inštalácii všetkých stĺpiky, Drenáž

Všetky otvory smerujú nahor.

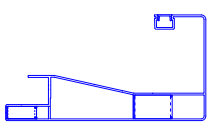
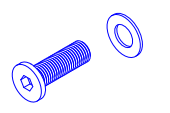
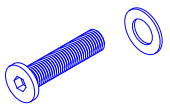
B-1 B-3		x 2
⑤		x 8
⑥		x 8

Zostavte rámeč

2) Ako je znázornené, vložte nosník a odkvap (B-1, B-3) do príspevkov, potom upevnite nosník a odkvap (B-1, B-3) na stĺpiky pomocou šiesthranných skrutiek M8*25⑤ a šiesthranné skrutky M8*35⑥.

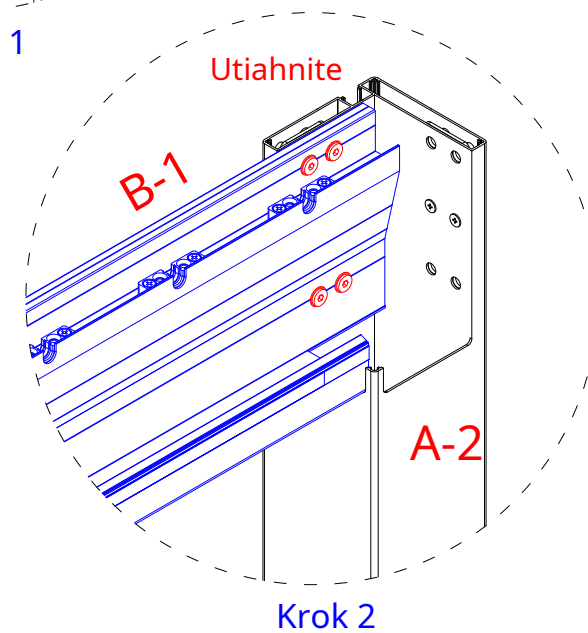
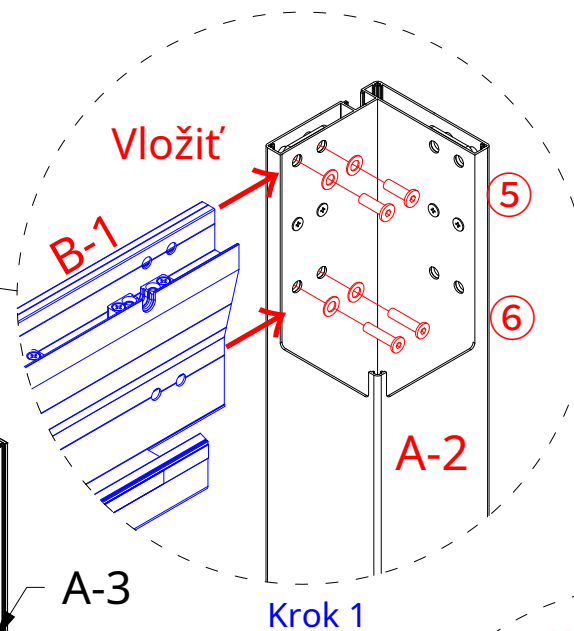
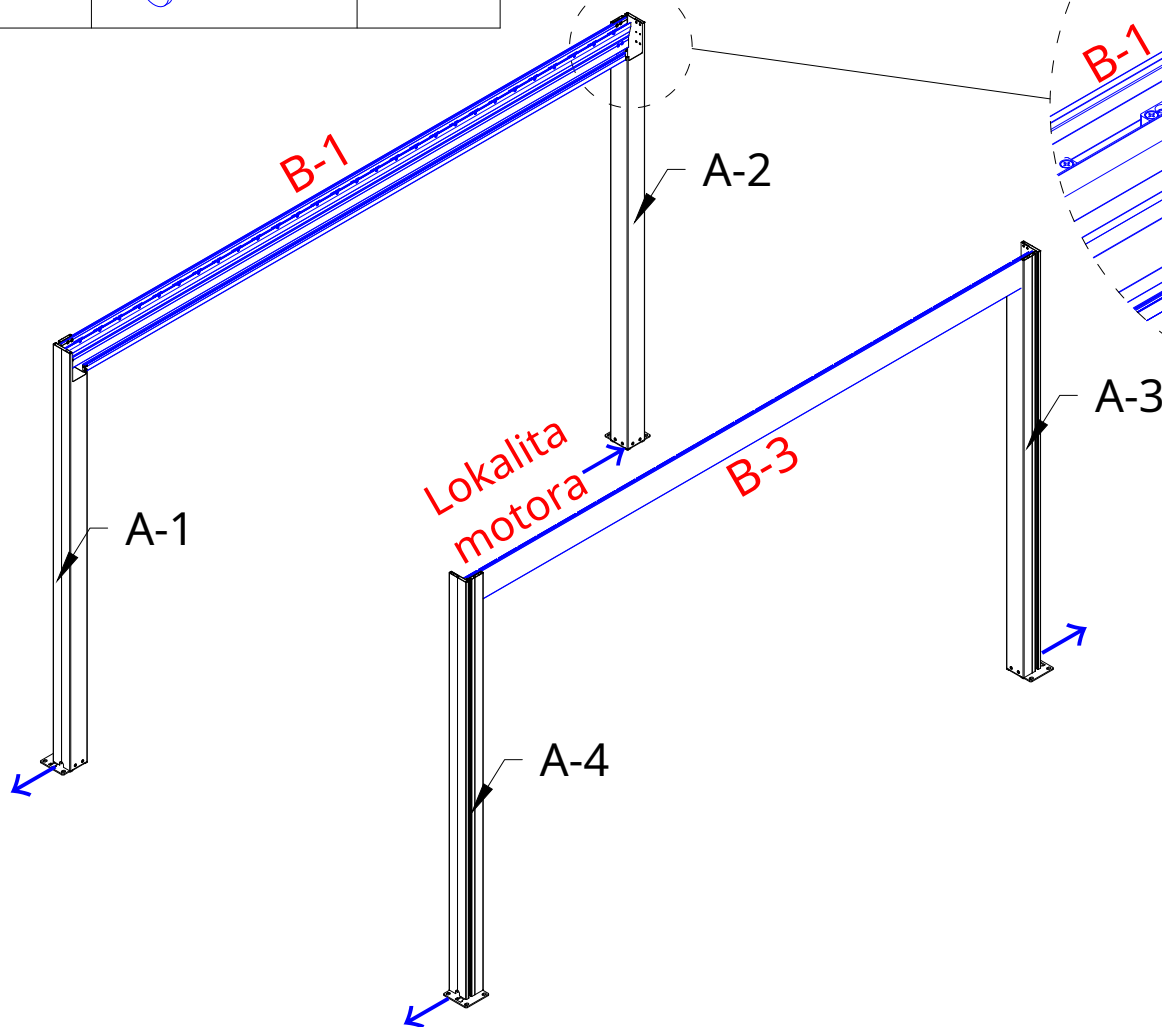

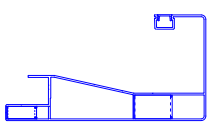
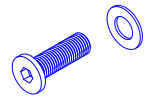
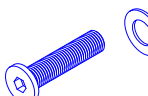
B-2 B-4		x 2
⑤		x 8
⑥		x 8

Zostavte rámec

3) Ako je znázornené, vložte nosník a odkvap B-2, B-4 do príspevkov, potom opravíte nosník a odkvap B-2, B-4 na stĺpiky pomocou šesťhranných skrutiek M8*25^⑤ a šesťhranné skrutky M8*35^⑥.

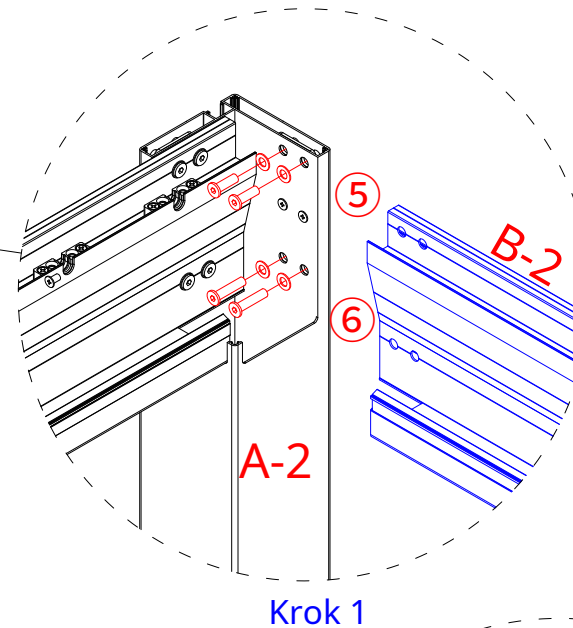
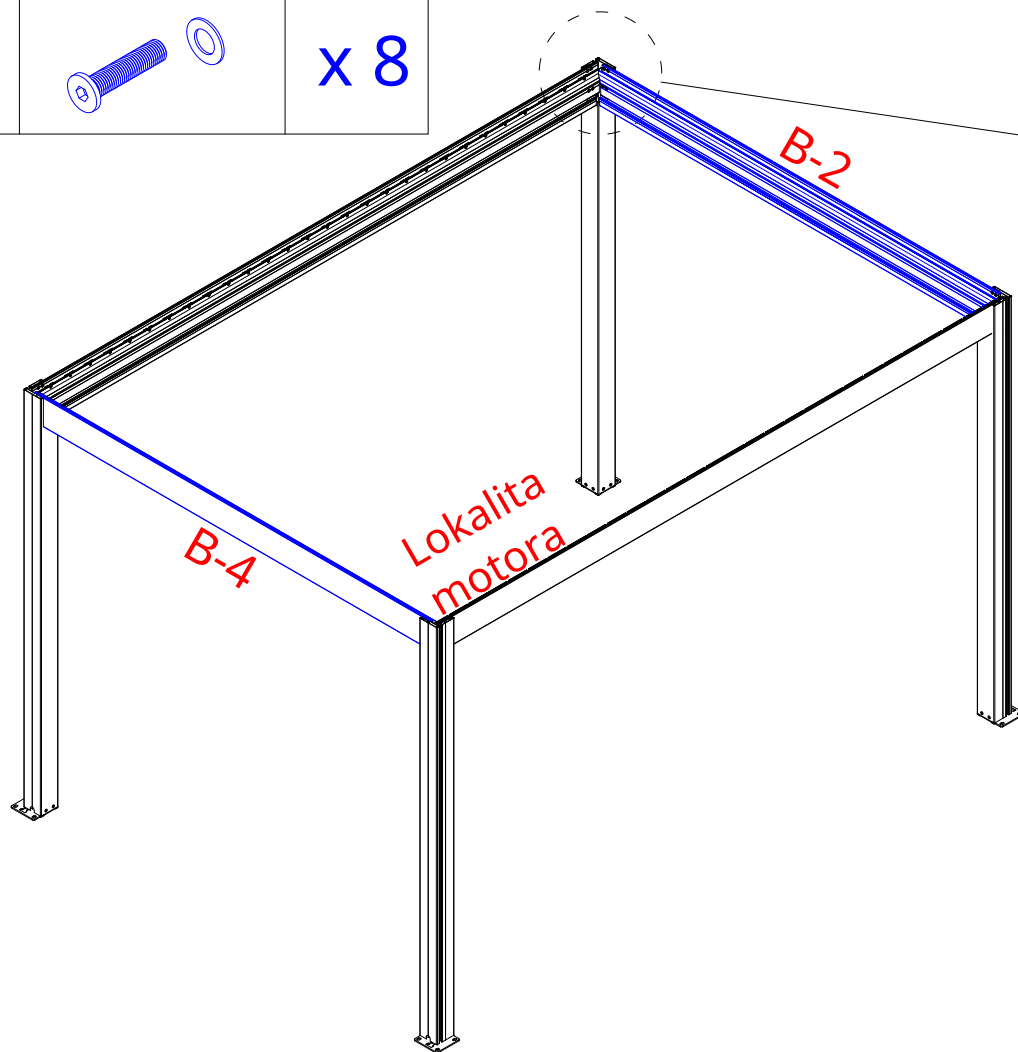

Krok 1

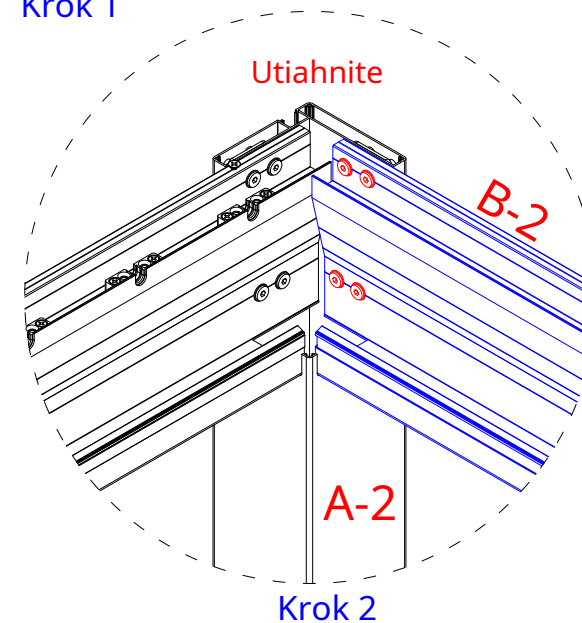

Utiahnite

Krok 2

7

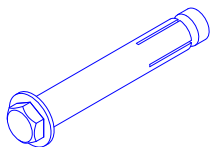

x 12

Poznámka:

Pred upevnením základovej dosky je potrebné zabezpečiť, aby uhlopriečky 4 stĺpikov mali rovnakú dĺžku. Uistite sa prosím o veľkosti $W1=W2, W3=W4$.

Pripevnite pergolu k zemi

- 1) Použite 12 rozširujúcich skrutiek M8*80 7 za predpokladu, že na zemi je betónová podlaha. Ak nie, budete musieť nájsť iné riešenie, ako priskrutkovať pergolu na požadovaný povrch.
- 2) Presuňte pergolu do vhodnej montážnej polohy, potom ceruzkou označte polohu štyroch stĺpikov, vyberte pergolu a pomocou elektrickej vŕtačky vytvorte 12 otvorov podľa zn. Presuňte pergolu späť do polohy a zaistite základnú dosku pomocou rozpínacej skrutky M8*80 7.

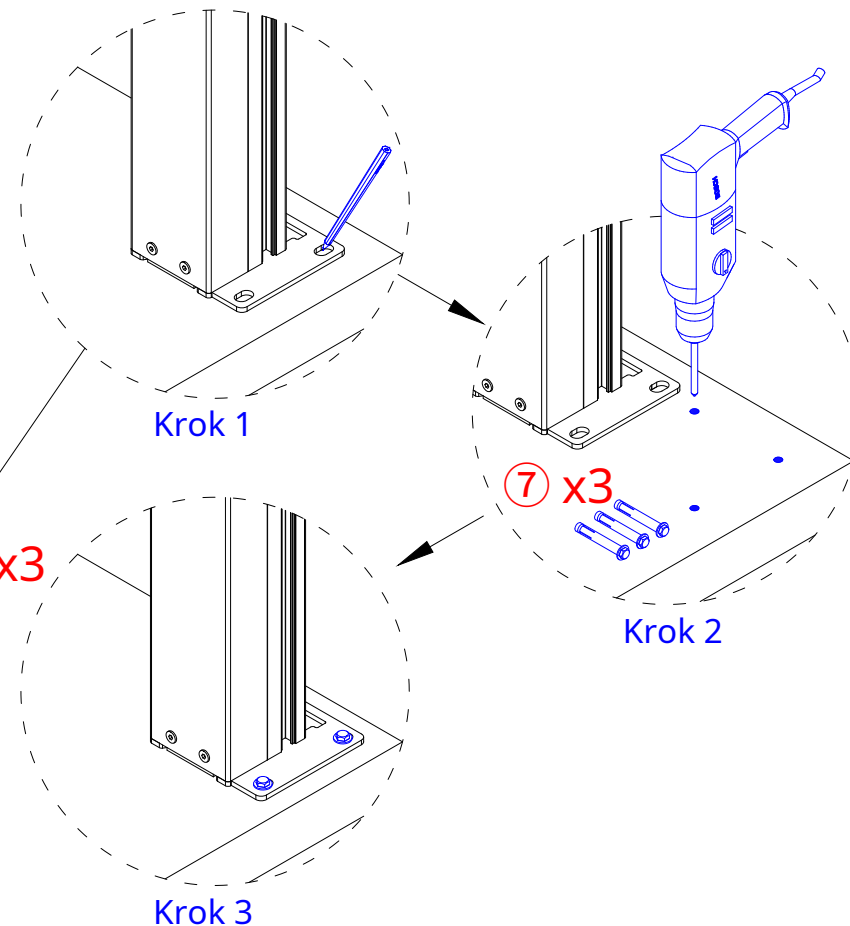
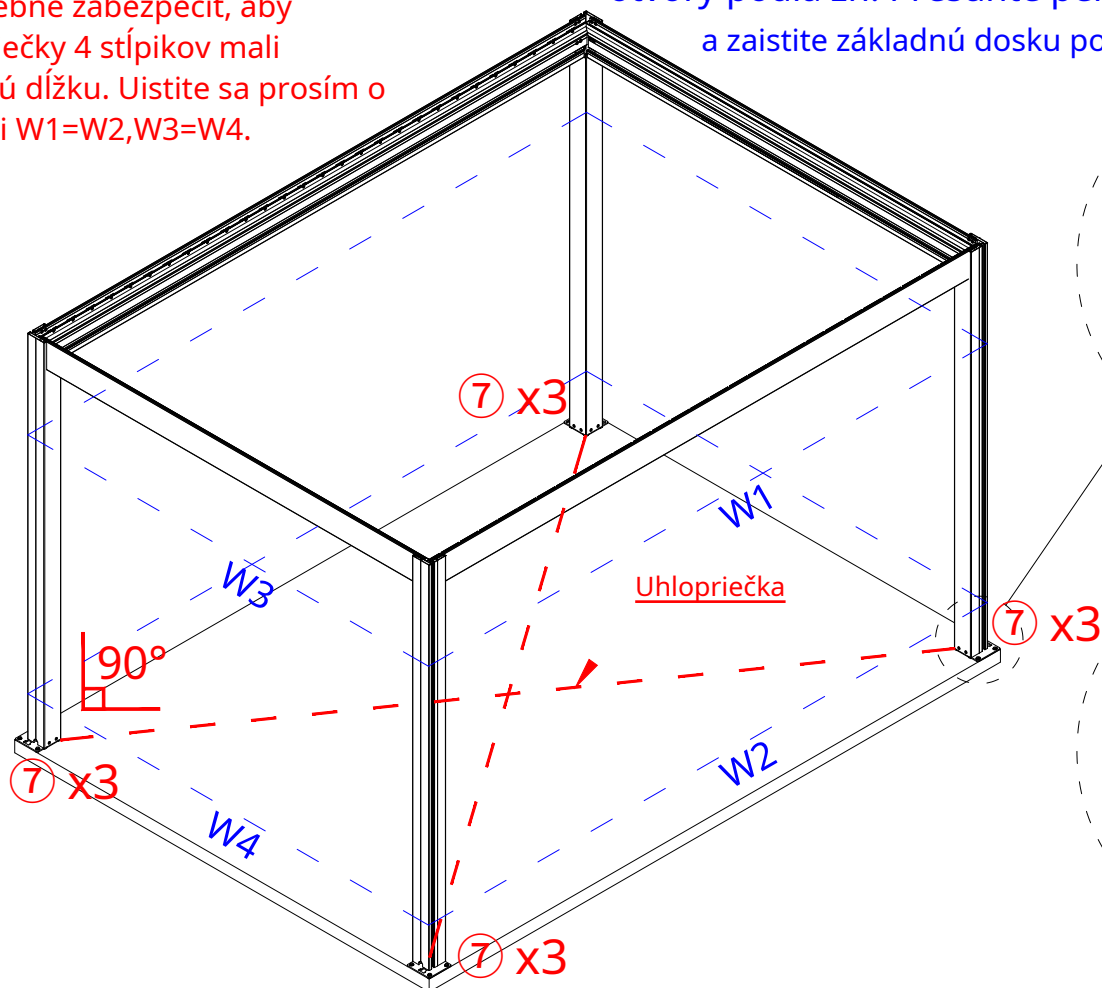

Je zodpovednosťou užívateľa zabezpečiť, aby bola pergola upevnená. Výrobca nezodpovedá za škody spôsobené živelnou pohromou alebo mimoriadnou udalosťou na pergole (alebo jej príslušenstve). Akákoľvek pergola, ktorá nie je upevnená, môže byť odfúknutá a spôsobiť poškodenie, pričom túto zodpovednosť nenesie výrobca. Pravidelne kontrolujte pergolu, aby ste sa uistili, že zostáva stabilná a pevne pripevnená k zemi. Na pergolu, ktorá sa oddelí zo svojej polohy a spôsobí alebo spôsobí poškodenie, sa záruka nevzťahuje.

 LED drôt

 Napájací drôt

Vedenie drôtov

Pri ukladaní drôtov ich zasuňte do stĺpika zo zárezu na hornom konci stĺpika, potom vytiahnite drôty k výstupnému otvoru, potom vytiahnite drôty z výstupu a nakoniec vytiahnite z otvoru v spodnej časti príspevku.

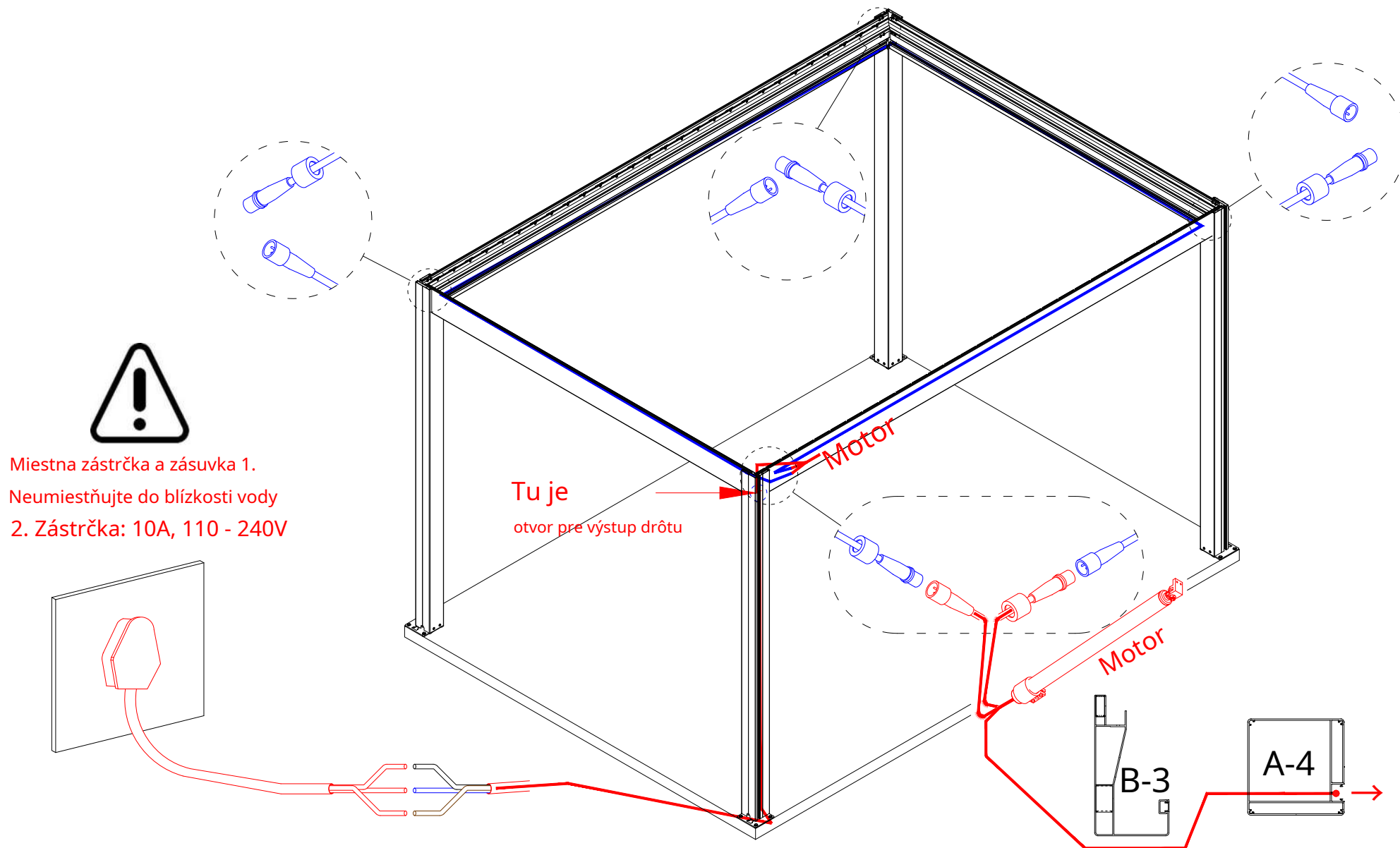



Poznámka: Postupujte podľa krokov na správne pripojenie kábla, inak bude motor chybný.



Zástrčka nie je súčasťou dodávky

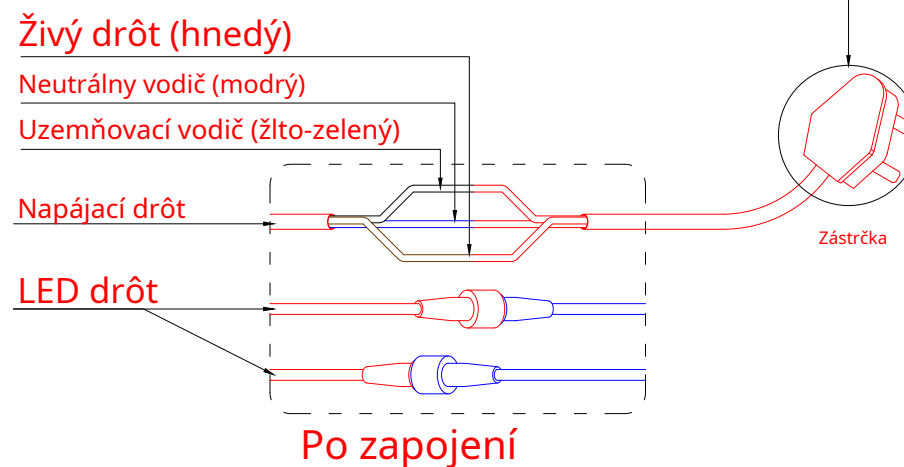
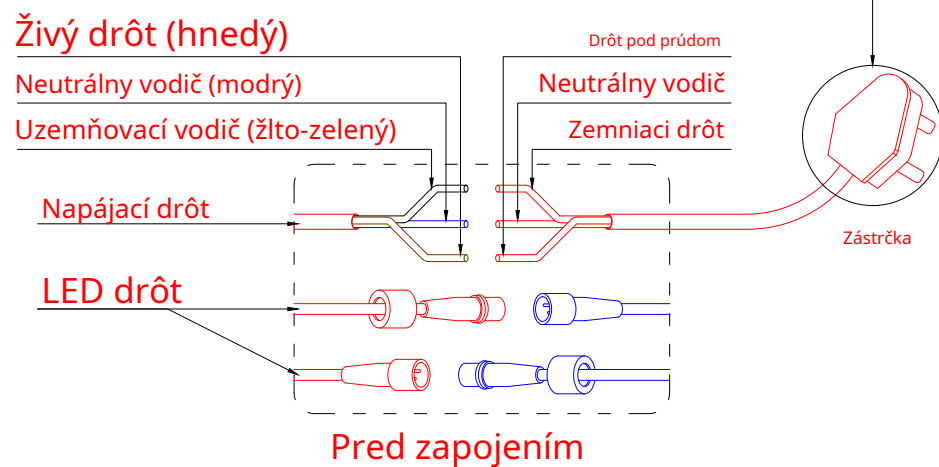

8

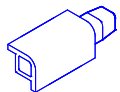

x 4

Upevnite rohový predĺžovací kus stĺpika

1) Ako je znázornené, zasunúť rohový predĺžovací kus stĺpika do hornej časti rohu stĺpika.

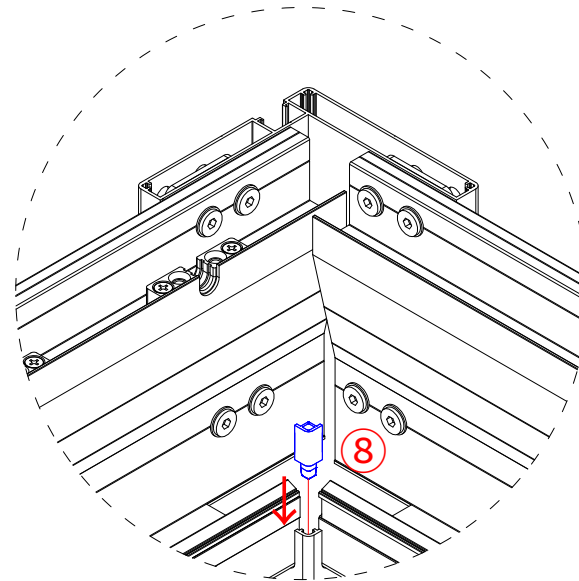
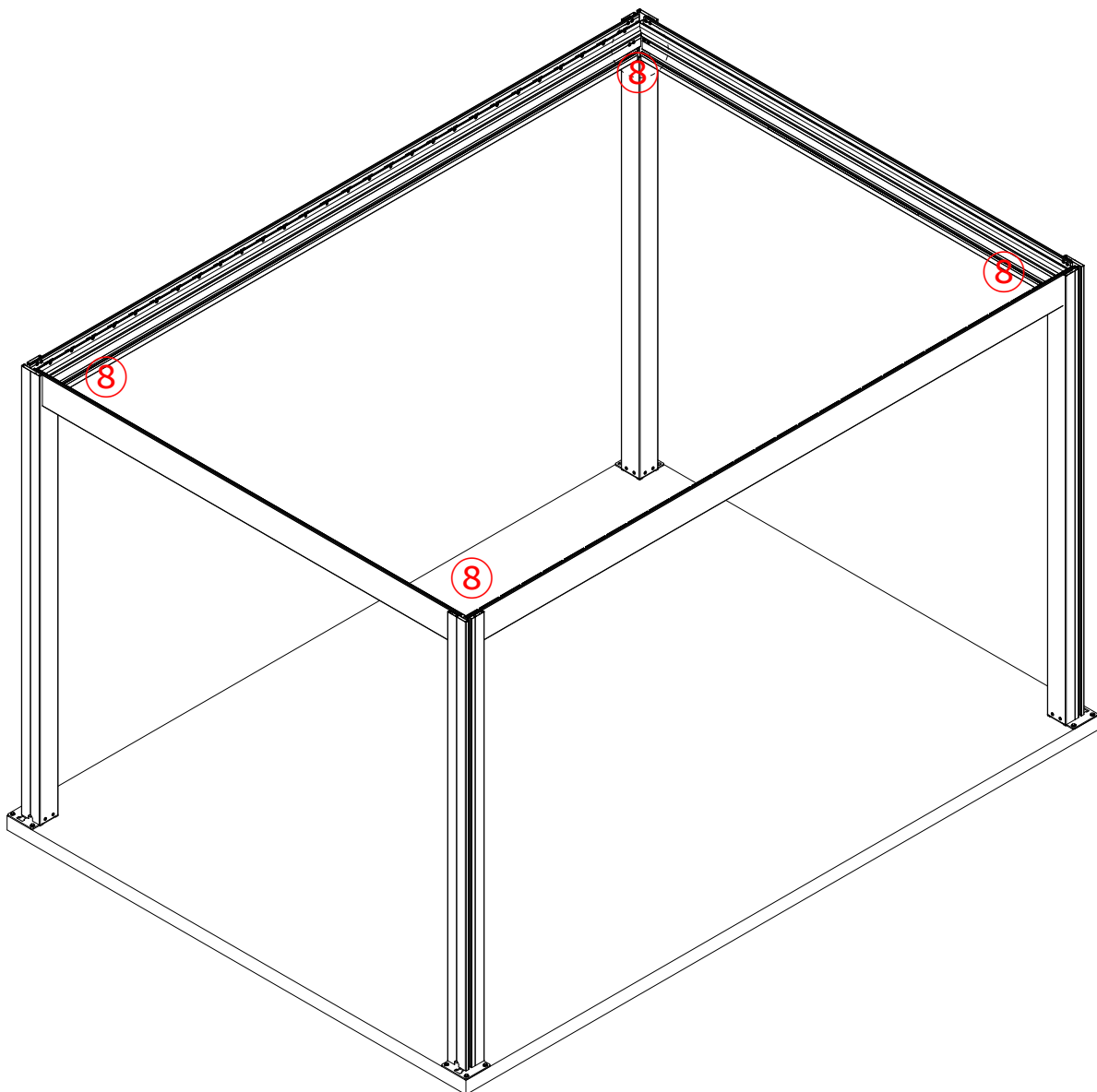

Krok 1

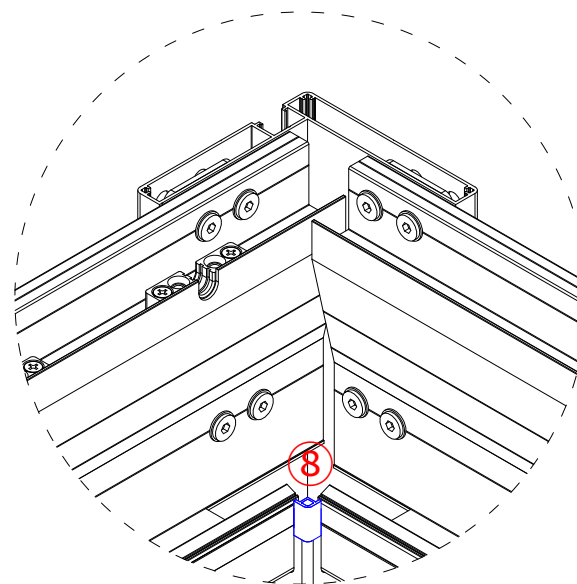

Krok 2

C-1**x 1**

Inštalácia Louvre

- 1) Ako je znázornené, mriežka na pripojenie motora C-1 zacvakne priamo do drážky.
- 2) Pripojte držiak ramena motora ku koncovému uzáveru mriežky na pripojenie motora C-1.

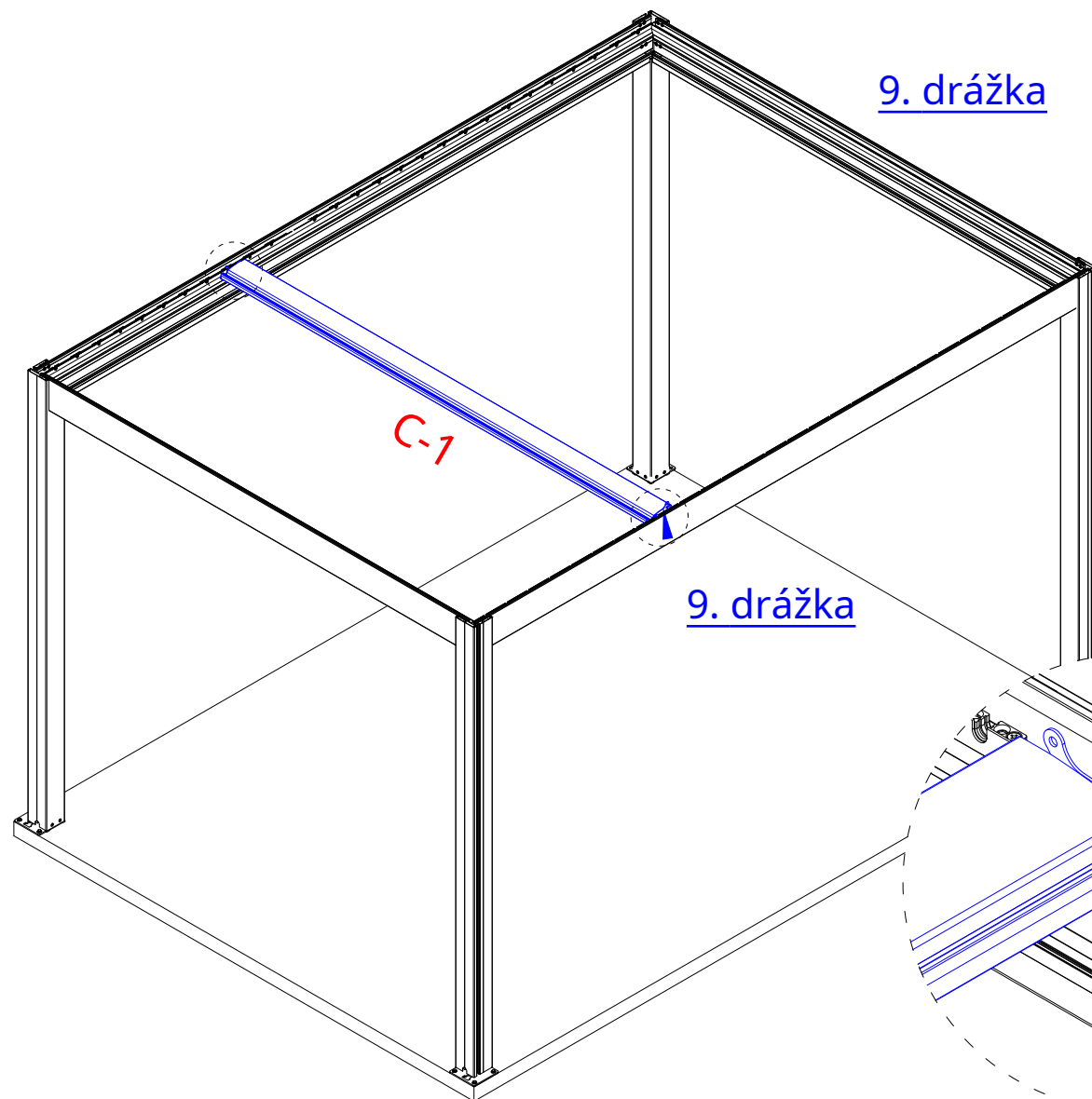
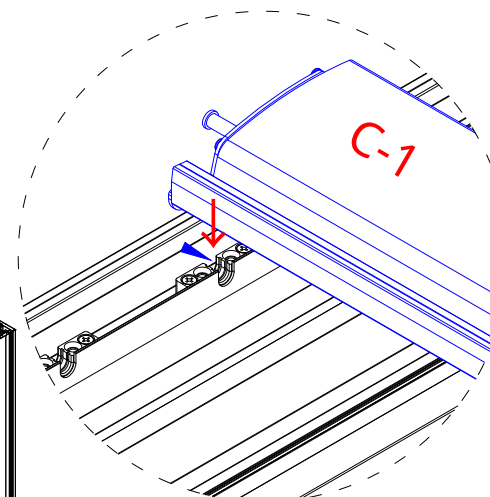
9. drážka**C-1**9. drážka

Krok 1

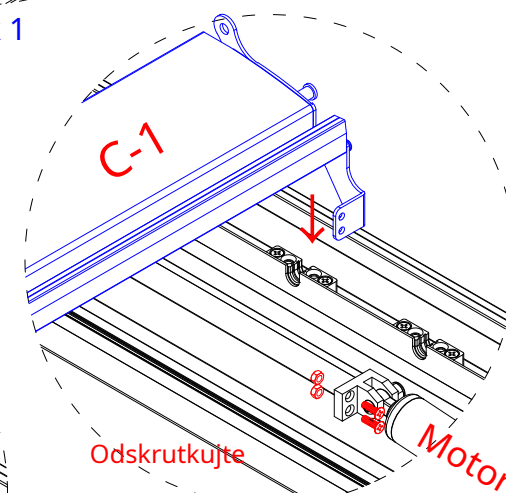

Odskrutkujte

Krok 2

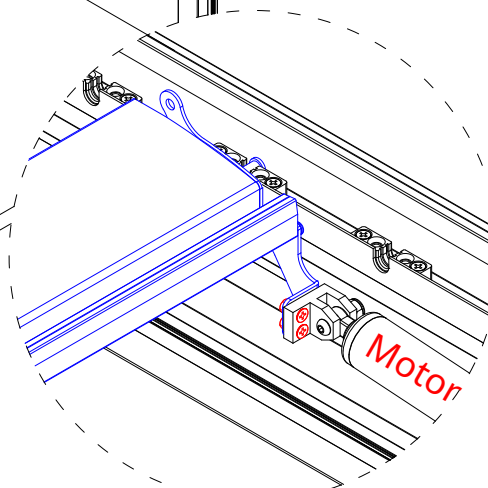
Motor

Krok 3

C-2 x 27



Inštalácia Louvre

3) Ako je znázornené, mriežka C-2 zapadne priamo do drážky.

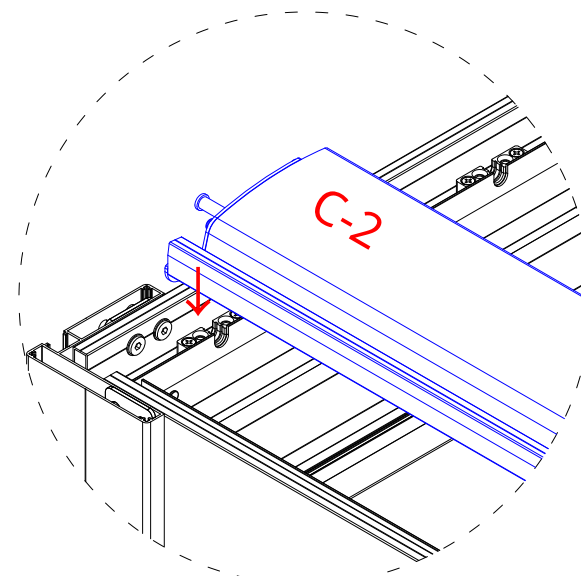
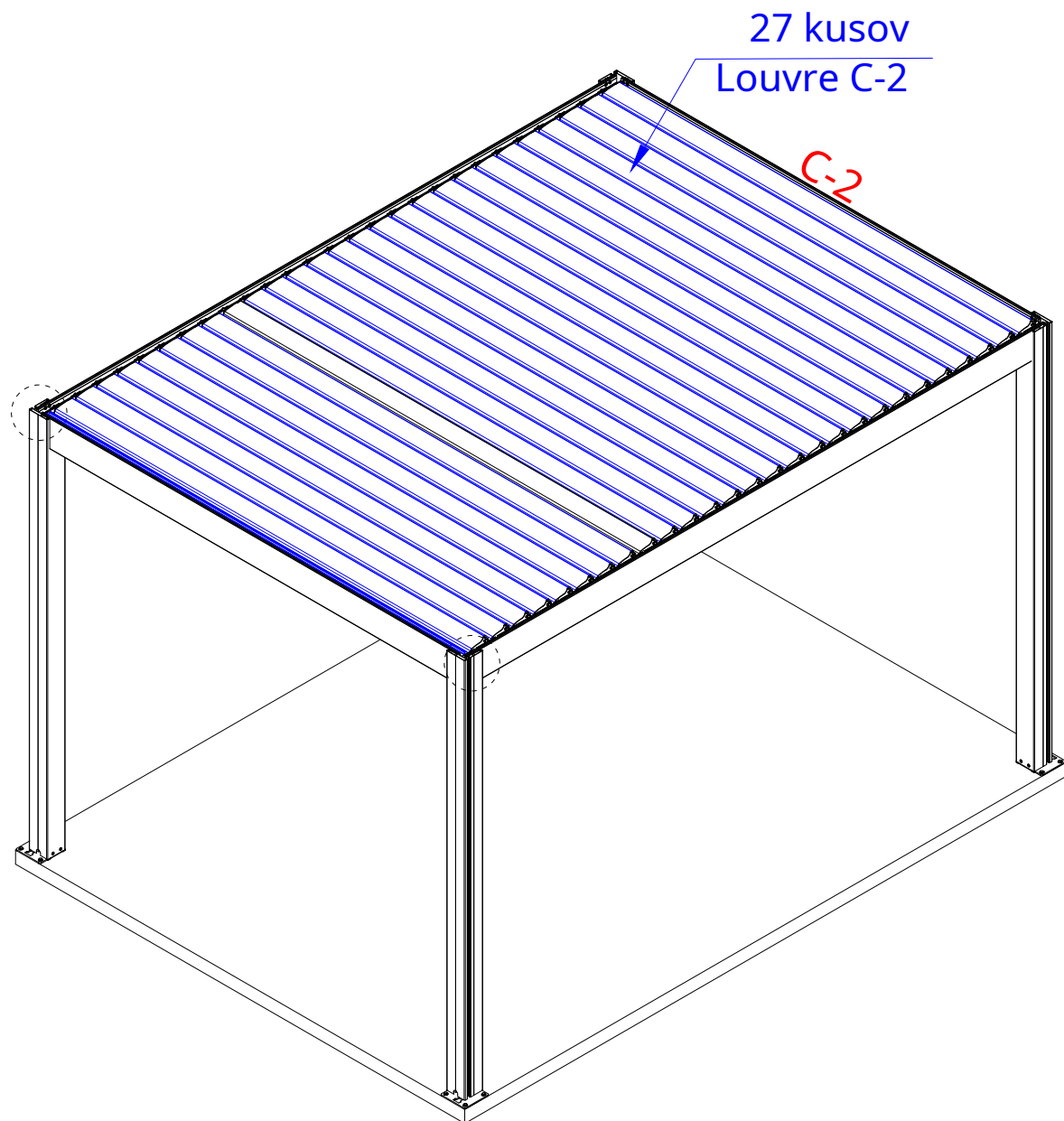

Krok 1

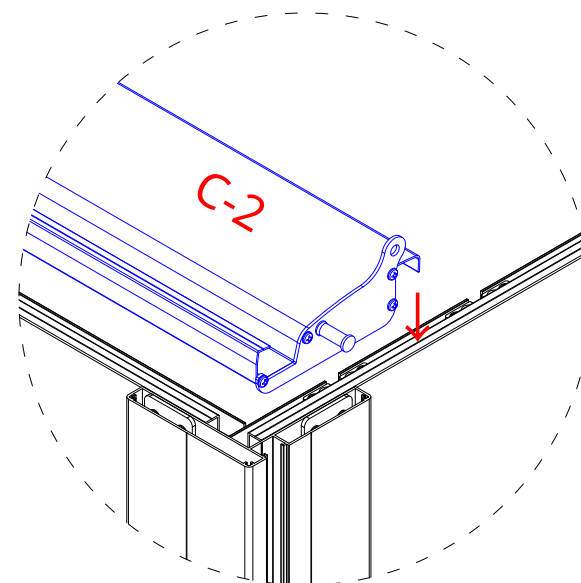

Krok 2

9

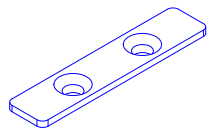

x 56

10



x 112

Inštalácia Louvre

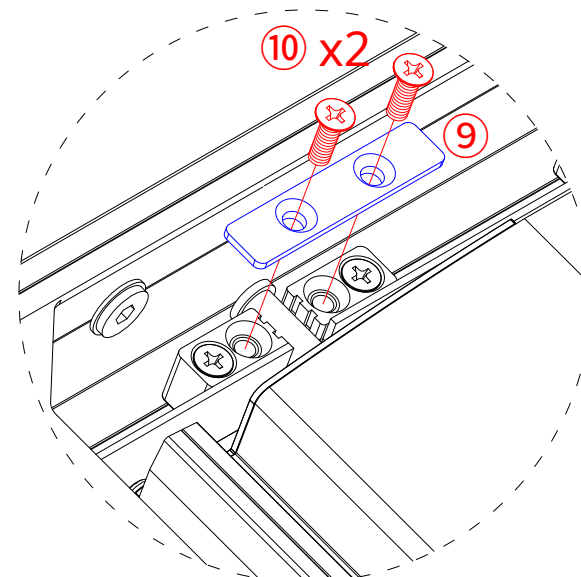
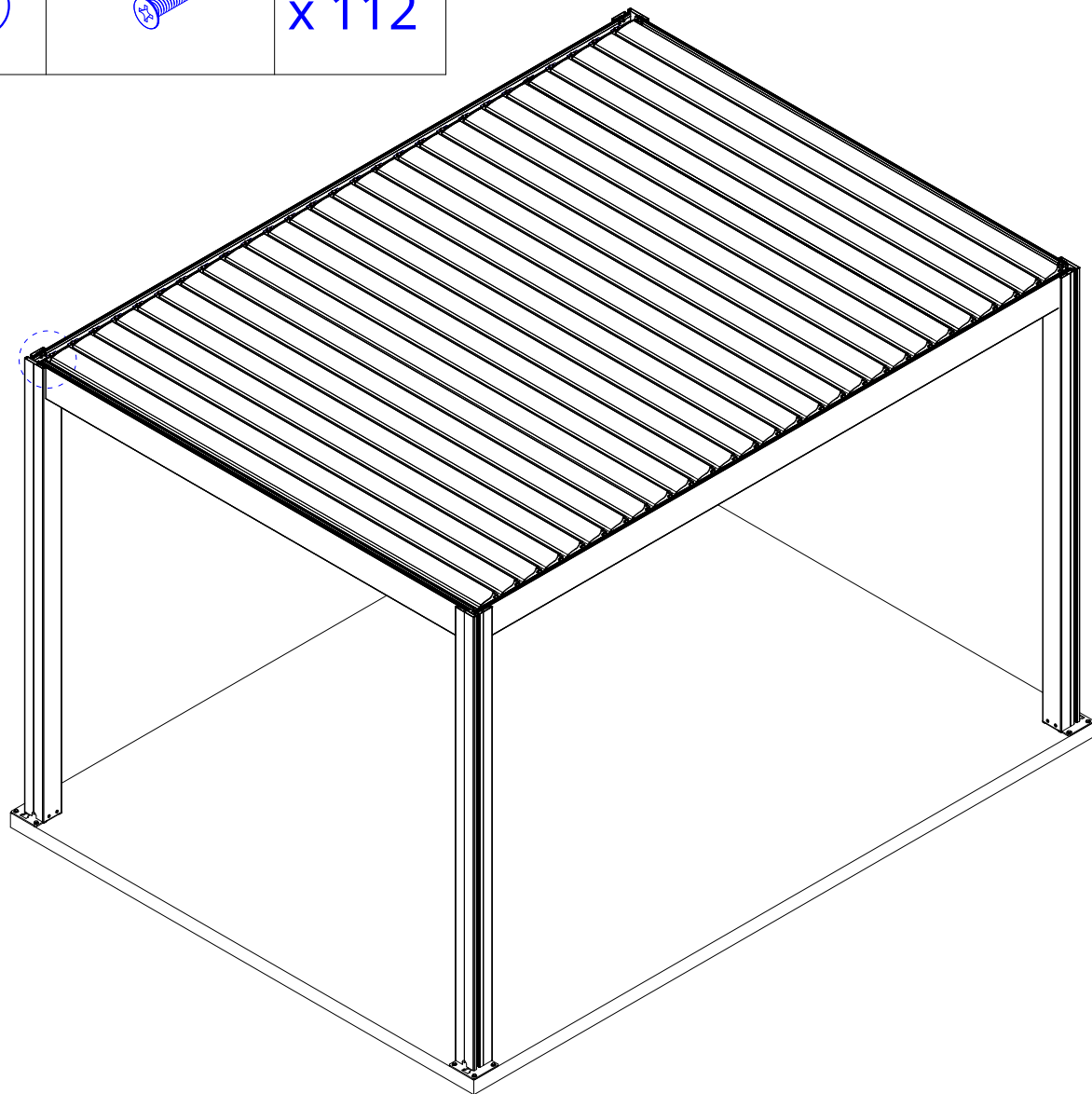

4) Ako je znázornené, upevnite kryt držiaka hriadeľa 9 zapnuté držiak hriadeľa s Zápusťnou skrutkou M5*16 10.

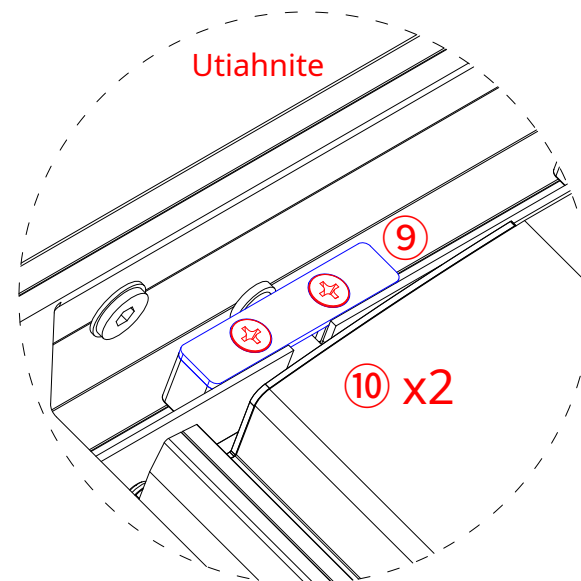

Krok 1



Krok 2

D		X 1
11		X 28

Inštalácia Louvre

5) Ako je znázornené, použite šesťhrannú skrutku M6*5 11 cez otvor (na ovládacej tyči D), potom upevněný na žalúzií.

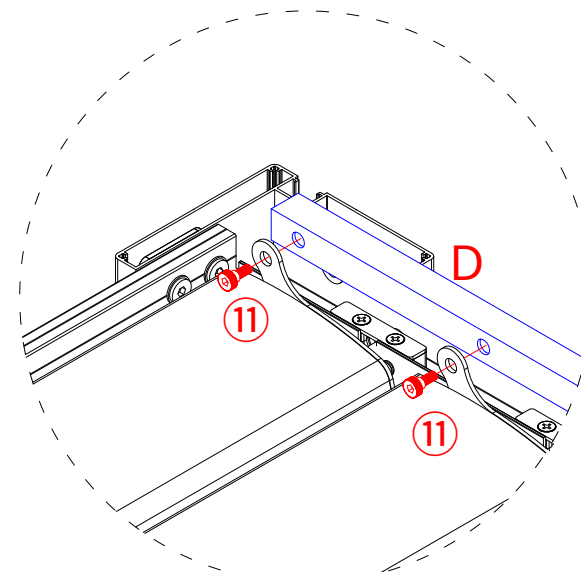
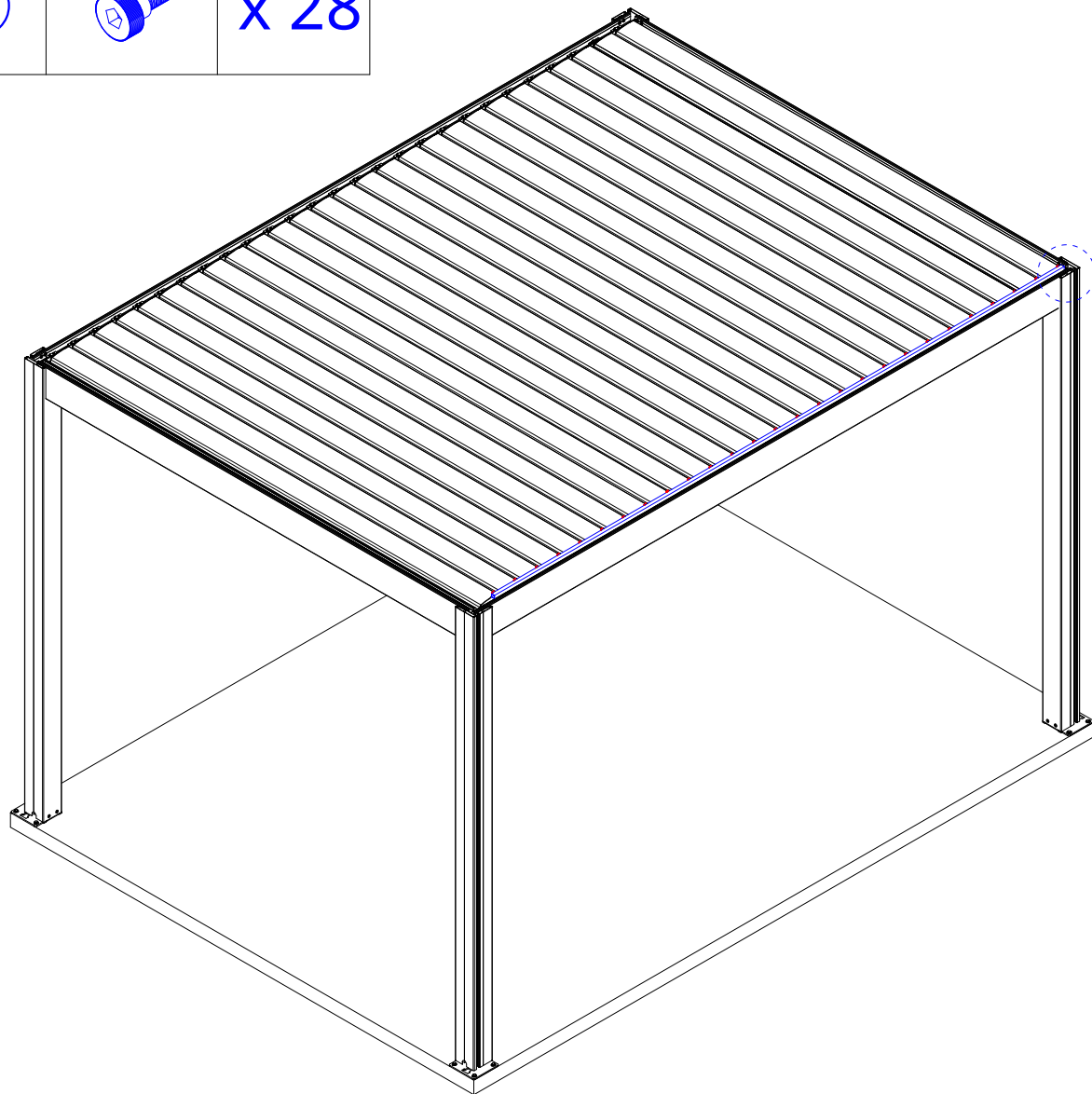

Krok 1

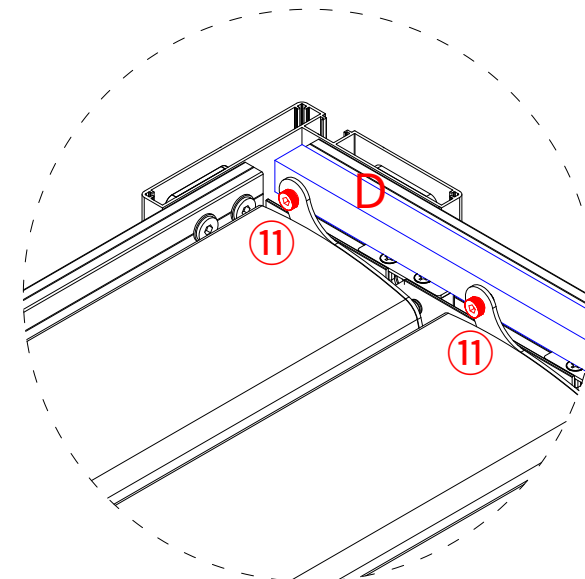

Krok 2

E**x 4**

Opravte kryt T-drážky

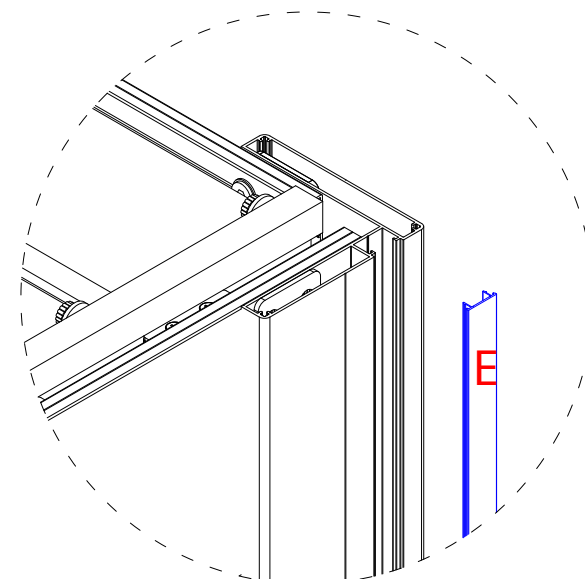
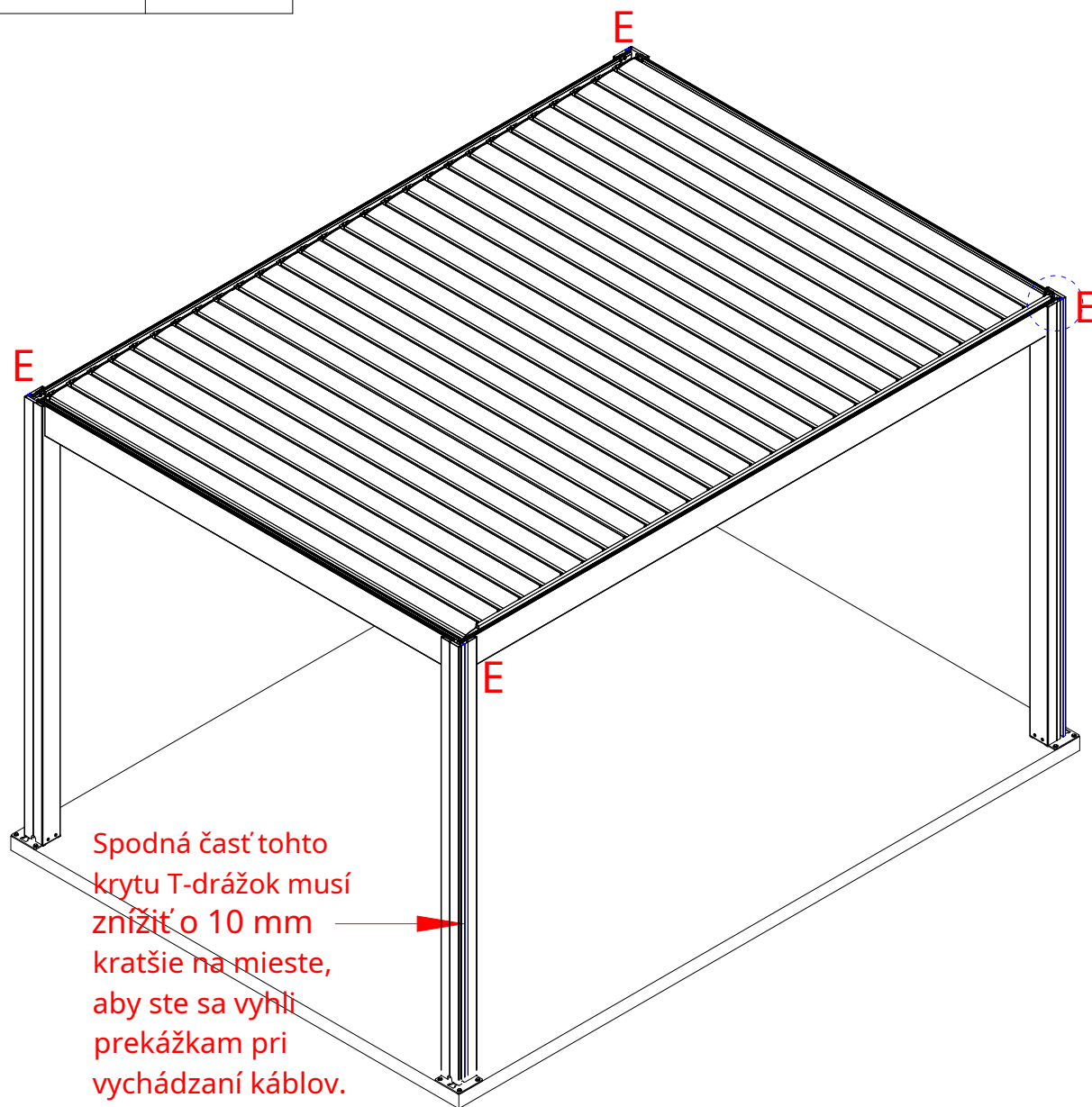

1) Podľa obrázka vložte kryt T drážky E do drážky stípika.

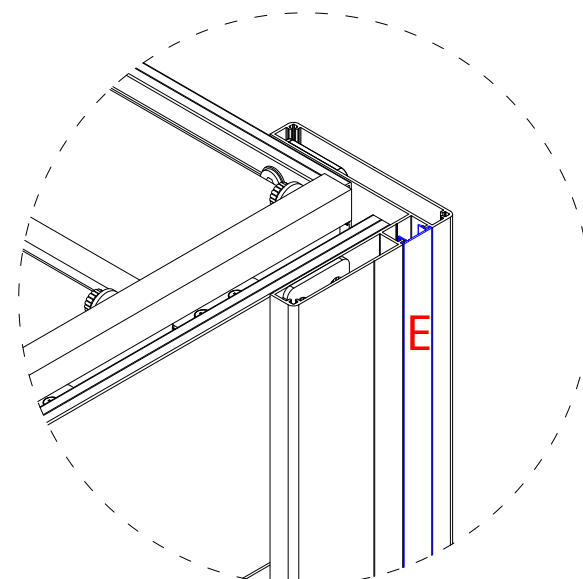

Krok 1

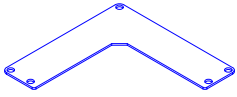

Krok 2

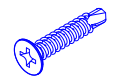
12		x 4
13		x 12
15		x 8

Upevníte horný kryt stĺpika

2) Podľa obrázka nasadíte koncovú krytku v tvare L¹² na vrch stĺpika a potom ho pripevníte 3 samoreznými skrutkami 4,2*16¹³ a 2 zo skrutiek 4,2 x 19 vrtákov¹⁵.

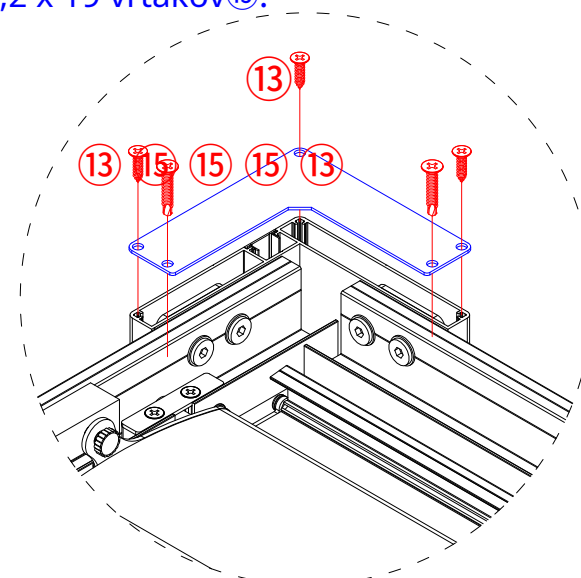
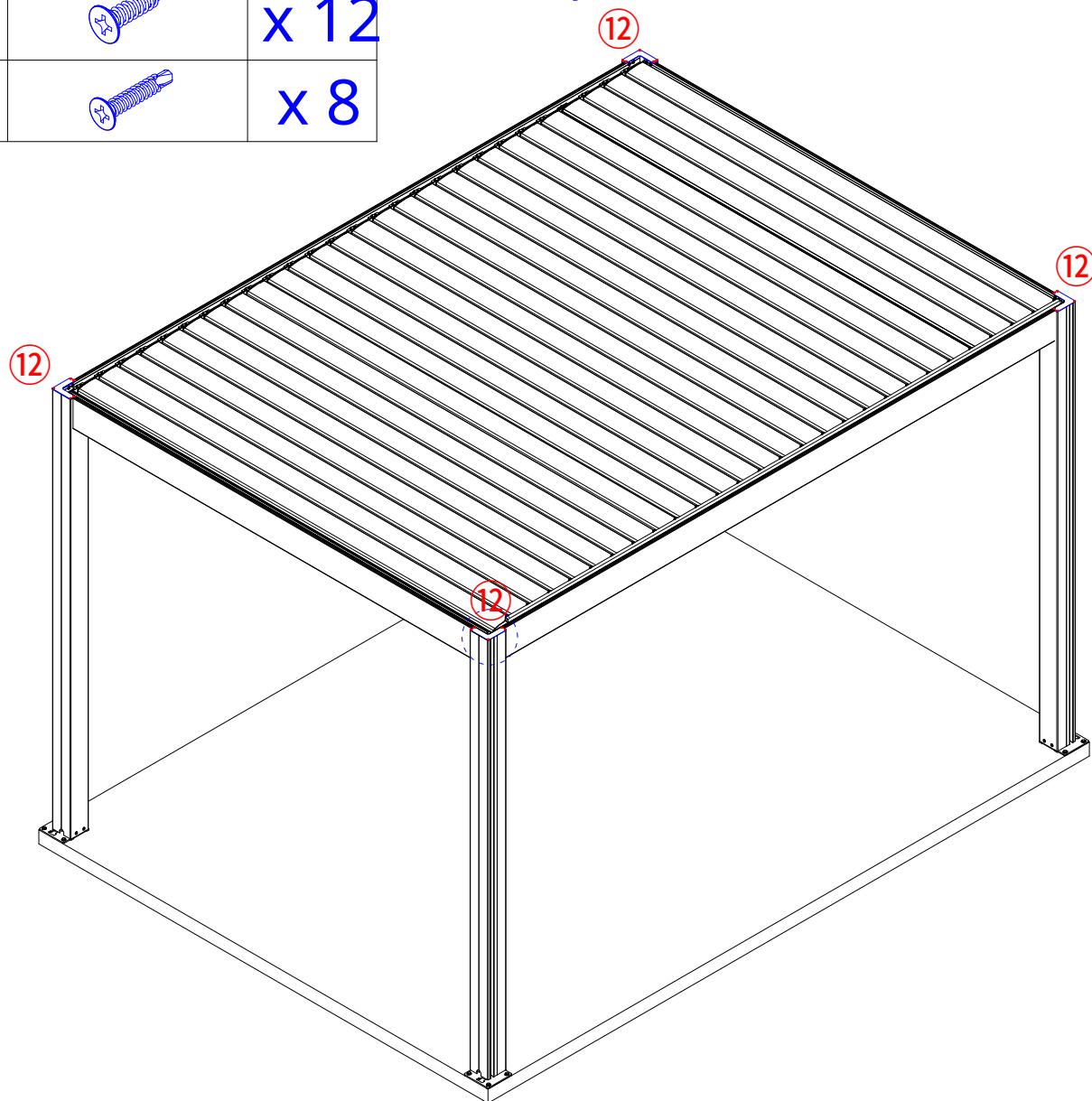

Krok 1

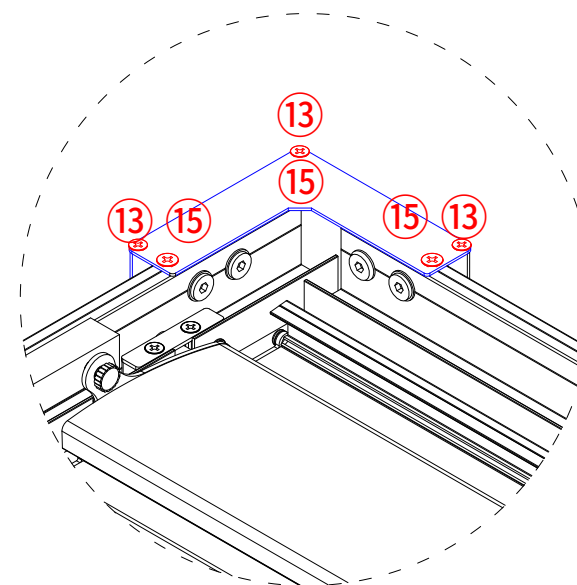

Krok 2

2

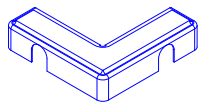

x 4

Inštalácia krytu základnej dosky

1) Ako je znázornené, zárez v tvare U na kryte základnej dosky by mal byť orientovaný v rovnakom smere ako odtokový otvor. Kryt základnej dosky na stĺpiku s dodatočným výstupným výrezom.

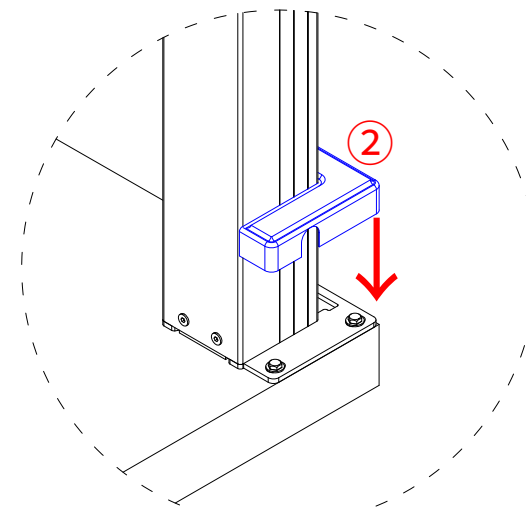
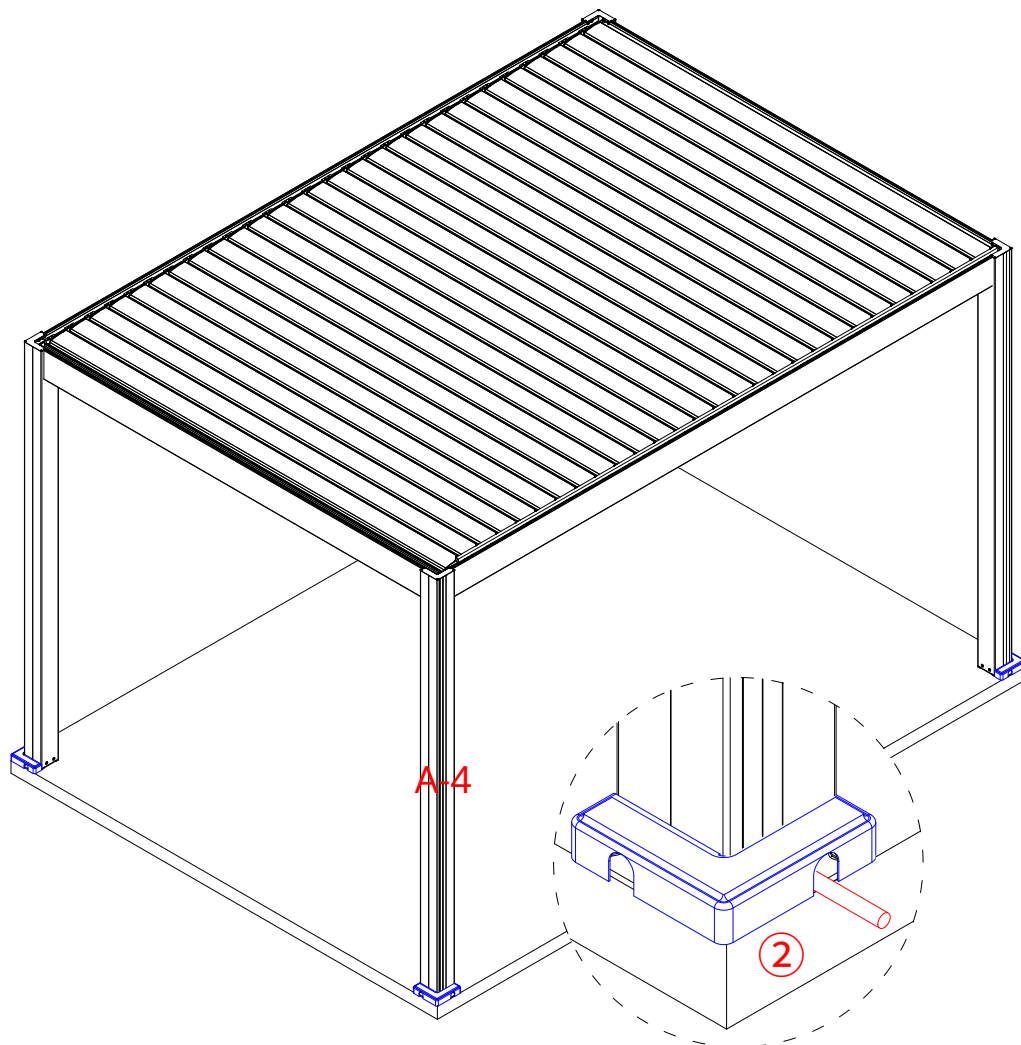

Krok 1

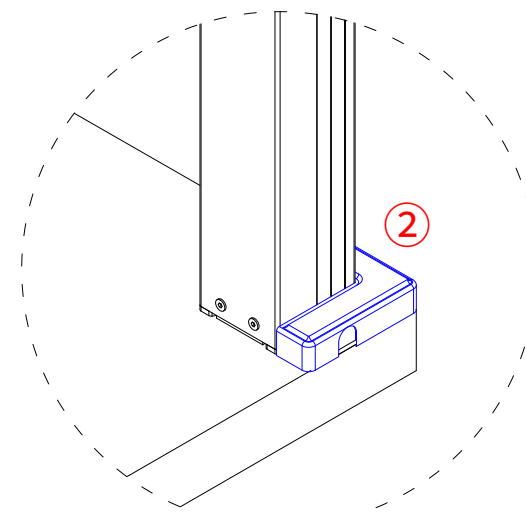

Krok 2

Ak diaľkové ovládanie a prijímač nemôžu ovládať motor, preprogramujte ho podľa nasledujúcich krokov.

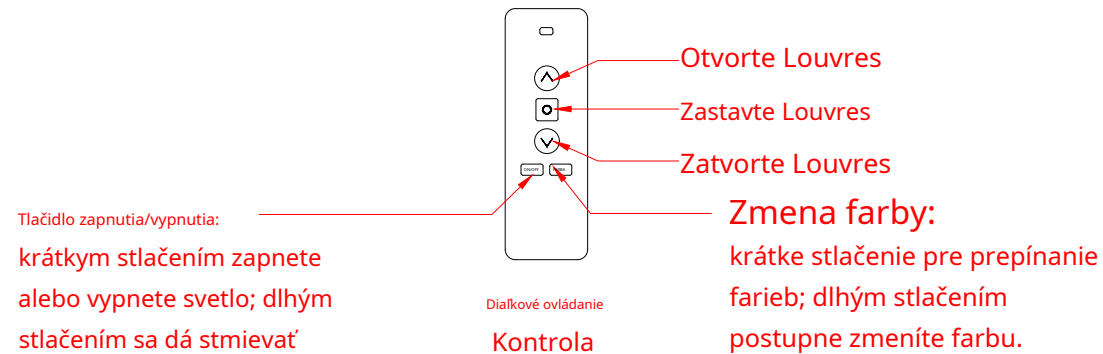

Kroky na párovanie:

1

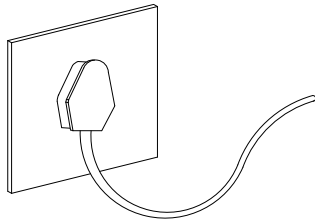

Vypnite napájanie na 15 sekúnd a potom ho znova pripojte, potom prosím začnite nasledujúce kroky do 30 sekúnd.

2



Otvorte zadný kryt diaľkového ovládača/prijímača, stlačte a podržte tlačidlo **tlačidlo U2** na viac ako 7 sekúnd.

3

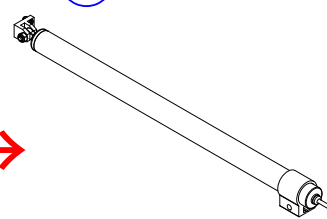

Keď motor pokračuje vo výrobe a "**beepbeepbeep**" zvuk.

4

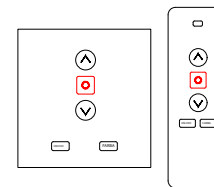

Stlačte a podržte **tlačidlo stop** diaľkového ovládača/prijímača znova na viac ako 2 sekundy. Keď "**beepbeepbeep**" Zvuk motora zmizne, znamená to, že diaľkové ovládanie/prijímač boli úspešne spárované.

Kroky na zmenu smeru:

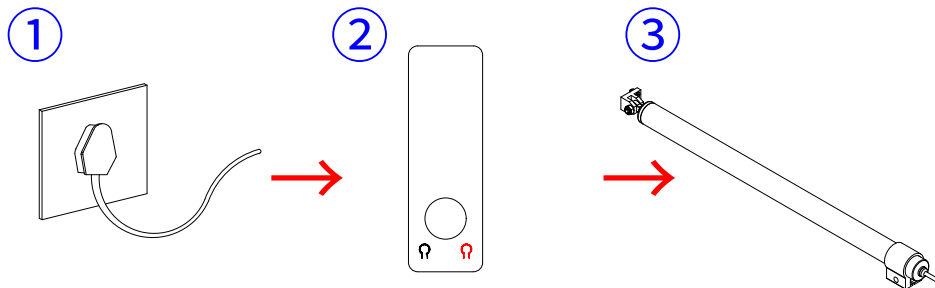

Vypnite napájanie na 15 sekúnd a potom ho znova pripojte sila teda prosím začnite nasledujúce kroky v rámci 30 sekúnd.

Otvorte zadný kryt diaľkového ovládača/prijímača, stlačte a podržte tlačidlo **U2** na viac ako 7 sekúnd.

Keď motor pokračuje vo výrobe a "beepbeepbeep" zvuk.

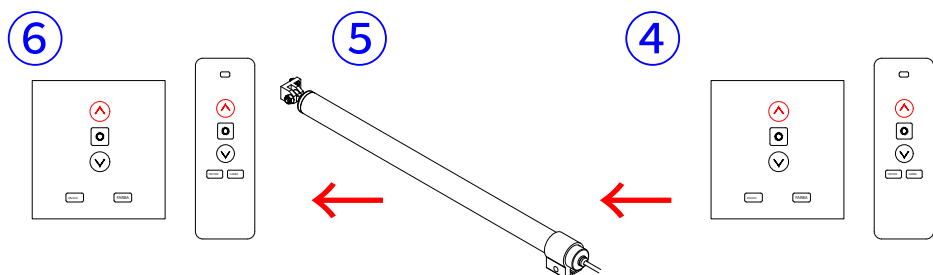

Stlačte a podržte tlačidlo **hore** diaľkového ovládača na viac ako 2 sekundy.

Motor robí a "beepbeepbeep" Znova zvuk

Stlačte a podržte tlačidlo **horez** diaľkový ovládač/prijímač pre viac ako 2 sekundy.

Kroky odstránenia párovania:

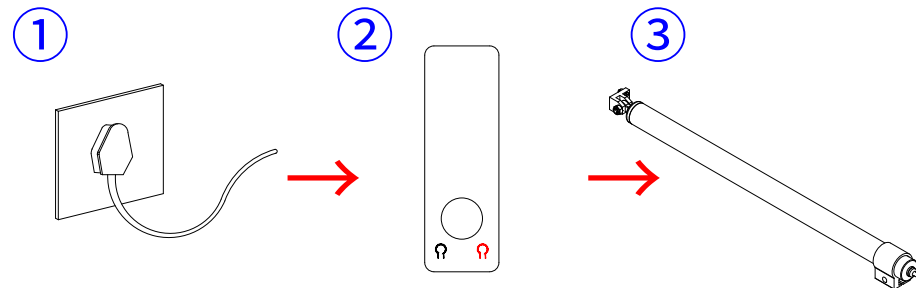

Vypnite napájanie na 15 sekúnd a potom ho znova pripojte sila teda prosím začnite nasledujúce kroky v rámci 30 sekúnd.

Otvorte zadný kryt diaľkového ovládača/prijímača, stlačte a podržte tlačidlo **U2** na viac ako 7 sekúnd.

Keď motor pokračuje vo výrobe a "beepbeepbeep" zvuk.

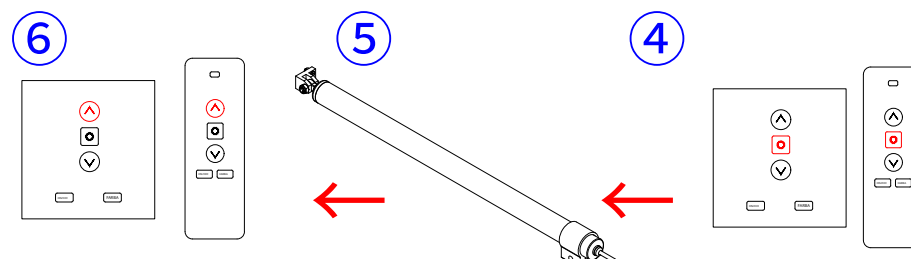

Stlačte a podržte tlačidlo **hore** diaľkového ovládača/prijímača pre viac ako 2 sekundy. Vymažte párovanie úspešne.

Motor robí a "beepbeepbeep" Znova zvuk

Stlačte a podržte tlačidlo **stop** diaľkového ovládača/prijímača pre viac ako 2 sekundy.

Starostlivosť o vašu pergolu

Povrchy konštrukcie natreté termosetovými práškovými farbami sa musia čistiť raz ročne, aby si zachovali svoj pôvodný estetický vzhľad.

Termosetové prášky sú citlivé na:

- Fyzikálne trenie, tvrdý náraz, vytlačanie, chemikálie vrátane alkalického rozpúšťadla a kyslého rozpúšťadla.
- Prírodné živly ako vietor, dážď, sneh a dlhotrvajúce slnečné svetlo. Exteriér pergoly sa môže časom zhoršiť a na to sa nevzťahuje záruka.

Čistenie vašej pergoly

- Nepoužívajte drôtenku, krémový čistič, brúsnu špongiu, železnú drôtenú guľôčku ani farebné utierky.
- Odporúčané: Mäkká špongia, mäkká handrička bez piesku, vata, bavlnený alebo netkaný papier (len biely).
- Nepoužívajte korozívne prostriedky, ako sú kyslé alebo alkalické čistiace prostriedky. Odporúča sa umyť vodou so saponátom s neutrálnym pH a potom utrieť handričkou, aby zostala suchá.
- Pri čistení vysokotlakovým zariadením je potrebné dodržať rovnaké opatrenia ako pri čistení karosérie: je potrebné zvážiť vzdialenosť, typ trysky, teplotu vody a tlak.

Použite Pripomenutie

- Po dokončení inštalácie skontrolujte pevné utiahnutie skrutiek. Nezabudnite skontrolovať skrutky aspoň raz za rok.
- **V prípade, že sa očakáva sneženie, krupobitie alebo silný vietor s rýchlosťou nad 80 km/h, odporúča sa otvoriť lamely žalúzie. Nepoužívajte nože v prípade mrazu alebo snehu. Prosíme, odstráňte lopatky z pergoly, keď je sneh hojný.**
- Pravidelne kontrolujte podmienky tesnenia, aby ste sa uistili, že tesnenia alebo iné komponenty netečú.
- Pravidelne čistite nečistoty ako opadané lístie na pergole, aby ste zabránili upchatiu odtoku.
- Obmedzenia použitia: Vodotesné systémy, aj keď sú účinné, nie sú navrhnuté tak, aby zabezpečili úplnú hydroizoláciu. Silný dážď a silný vietor môžu pergolu poškodiť. Akékoľvek vzniknuté škody nebudú kryté zárukou.

BRUKSANVISNING

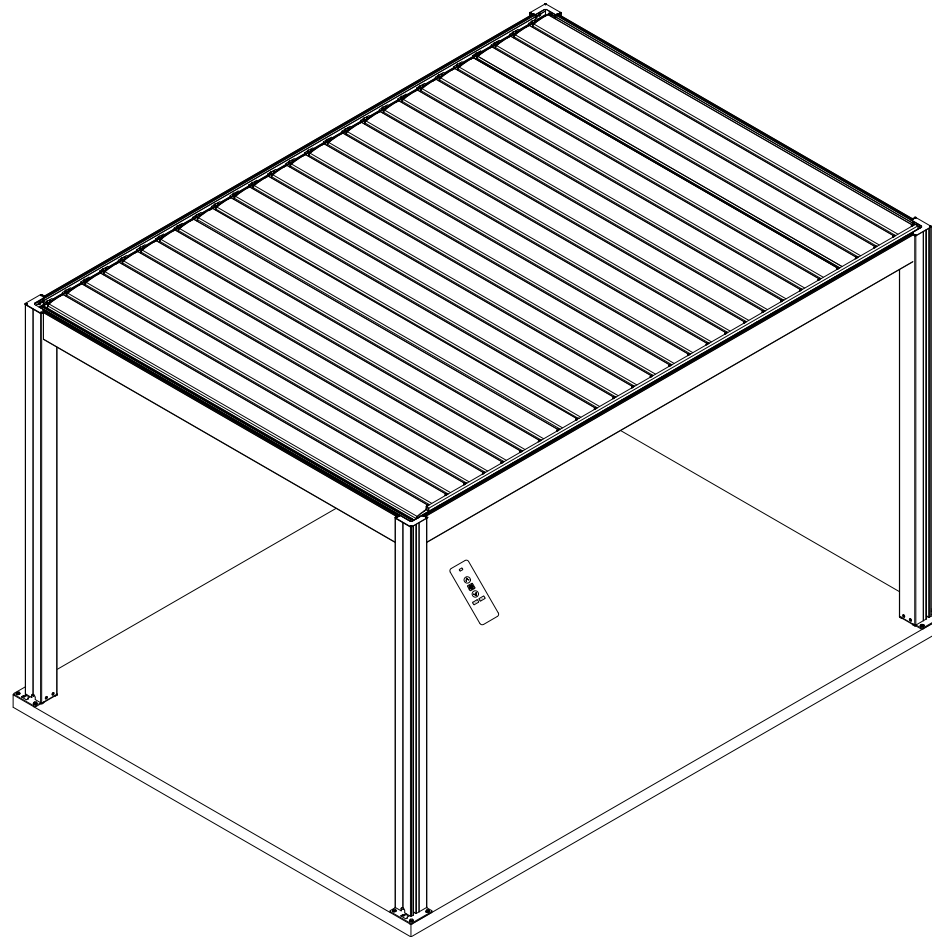

OTHER LANGUAGES

Pergola 4 x2,86m

Läs denna bruksanvisning innan du använder din pergola för första gången.
Vänligen spara denna manual för framtida referens.

Pergola

Öppning:Elektrisk

Storlek:295,3(Längd) x 409(Bredd) -centimeter

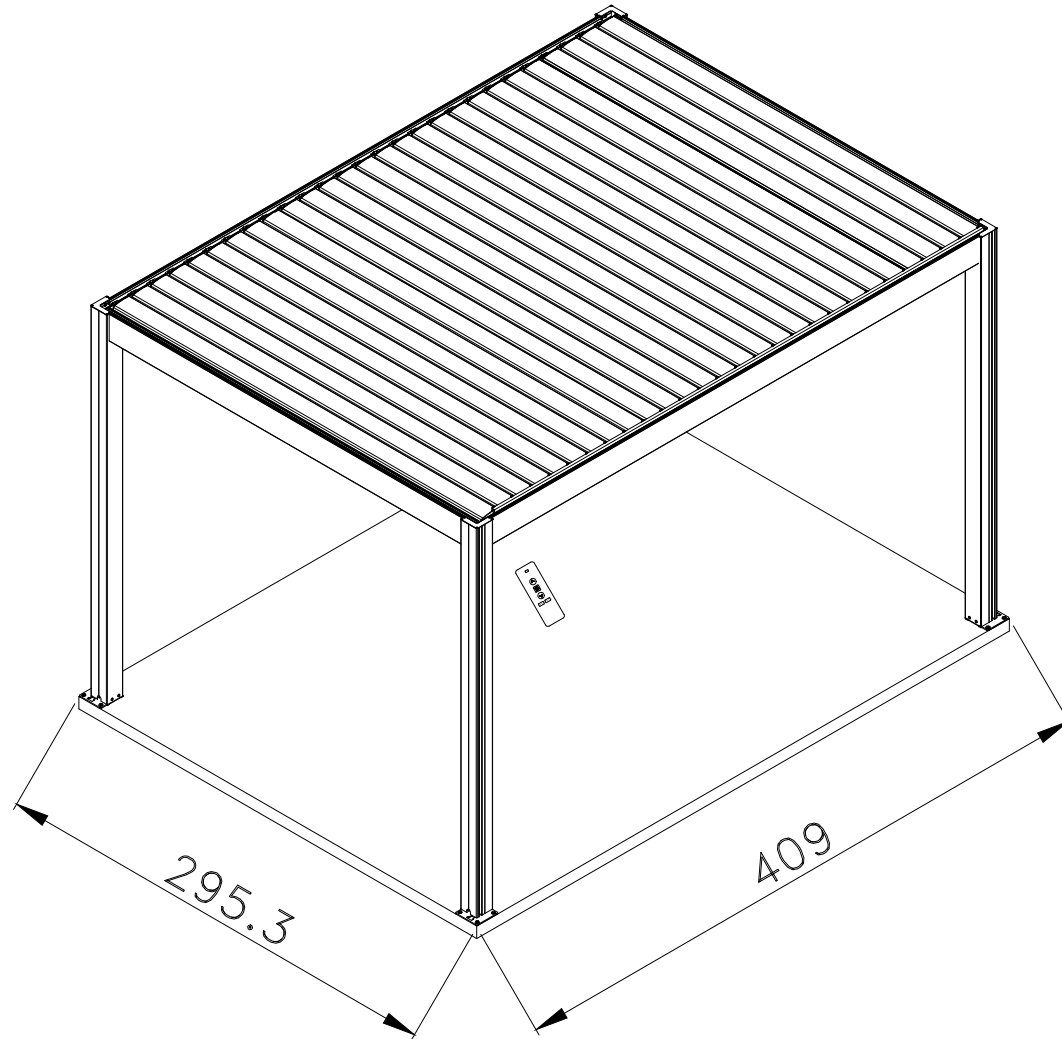

Installationsanmärkningar:

1. Installationen kräver minst tre personer: en för mätning och märkning, en för installation och en som assistent.
2. Endast fästelement för betonggolv tillhandahålls. I de fall där det inte finns någon betongplatta på marken, rekommenderas att göra betongplattor vid varje kolumn. Betongplattan bör vara ett minimum av 500x500x500mm.
3. Efter att Pergola-ramen har monterats, använd en fyrkant, nivå och linjal för att mäta produktens nivå och diagonal för att säkerställa storleken på pergolan. Baserna måste vara exakt jämna utan tolerans.
4. Pergolan måste skruvas fast i golvet. Vi tar inga ansvar om plattor spricker vid borrningen av bultarna.
5. Elverktyg krävs: se till att de fungerar korrekt och följ säkerhetsinstruktionerna.
6. Var försiktig när du använder vassa verktyg.
7. Bär skyddskläder inklusive skyddsglasögon, hjälmar och handskar.
8. Klättra eller stå inte på taket.

Säkerhetsvarning

- . Det rekommenderas starkt att bära handskar vid montering.
- . Installera inte pergola under dåliga väderförhållanden, som vind eller regn.
- . Rör inte några ledningar med aluminiumprofiler.
- . Bär alltid skyddsskor och glasögon när du installerar pergola.
- . Förvara alla plastpåsar utom räckhåll för barn.
- . Pergolapelaren måste placeras och fixeras på en plan yta.
- . Luta dig inte mot kolonnen under monteringsfasen.
- . Låt inte barn närma sig platsen under monteringsfasen.
- . Var inte nära pergolan i en storm eller tyfon.
- . Försök inte att klättra pergola under påverkan av alkohol eller droger.
- . När du använder stegar eller liknande verktyg och elverktyg under monteringsfasen, se till att följa tillverkarens säkerhetsrekommendationer.
- . Alla heta verktyg, såsom en elektrisk borrar, kan inte komma i kontakt med pergolaprofilen.
- . Se till att det inte finns några kablar eller andra kablar gömda under jord innan du placerar kolonnen.

Allmänna råd

- . Denna pergola har flera komponenter och den tar minst 90 minuter att montera. Pergolan bör inte placeras under ett träd.
- . Om du ansluter pelaren direkt till cement eller liknande bas, använd förstansade hål på den medföljande basen.
- . Kontrollera antalet profiler och beslag före montering och använd dem enligt listan över profilbeslag för enkel montering.
- . Lägg små bitar som skruvar i en behållare för att undvika förlust.
- . Var uppmärksam på transmissionens position på balken för att undvika felplacering.
- . Rengör regelbundet löv, snö eller andra föremål från pergolan.

Underhåll och reparation

- . För att rengöra pergola, använd ett mildt rengöringsmedel och skölj med vatten. Använd inte aceton eller slipande rengöringsmedel för att rengöra ytan på aluminiumprofilen.

Garanti

- . Den allmänna garantin för missfärgning är 5 år, för motor och LED-belysning 2 år.

Skydds- och installationsverktyg

Skyddsutrustning:

1. hjälm
2. Handskar
3. Första hjälpen nödlåda
4. Skyddsglasögon



Mätinstrument:

1. Måttband (5 meter eller mer)
2. Fyrkantig linjal
3. Nivå

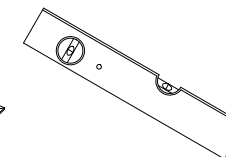
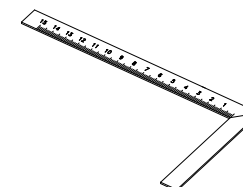
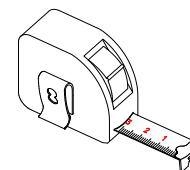



Verktyg:

1. 2 meter stege (1,5 meter eller mer)
2. 13 mm insexnyckel
3. 17 mm insexnyckel
4. Elektrisk borrar
5. Elektrisk borrar (10 mm borrar)
6. Markör eller penna
7. Gummihammare
8. Tätningmedel och limpistol





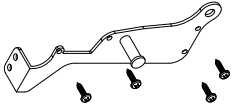
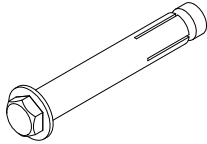
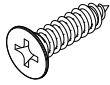
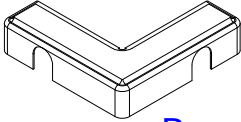
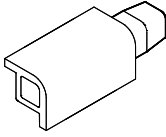
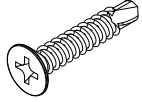
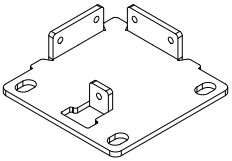
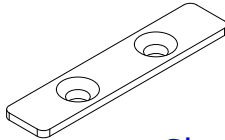
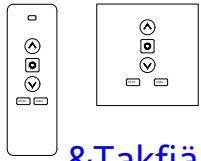
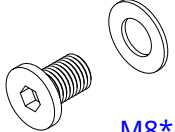

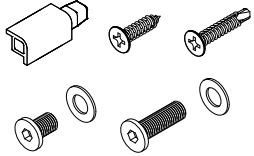
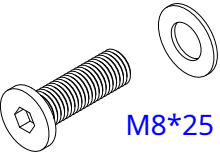
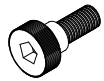
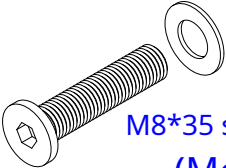
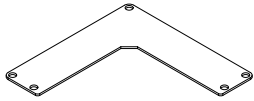

Silicon

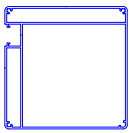
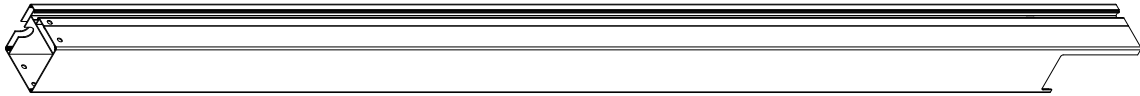
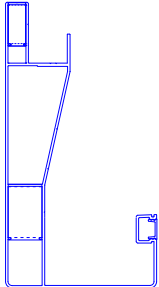
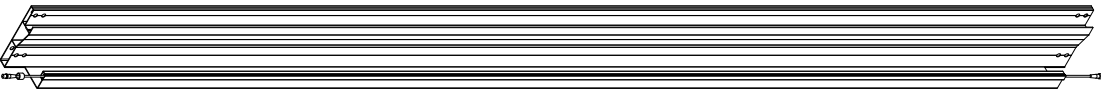
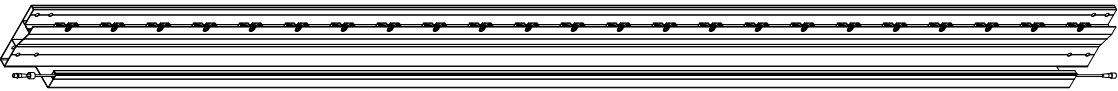
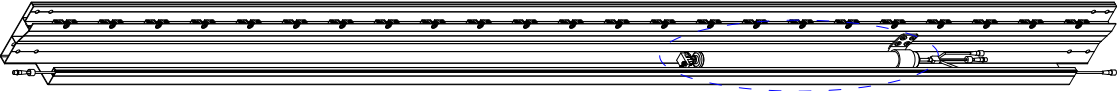
Tillbehör & skruvlista

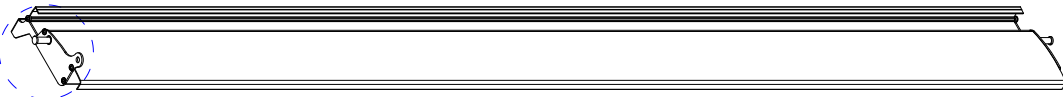
<p>①</p>	 <p>x 1 Ändlock för Motoranslutningsbländskydd &4*20 skruvar med platt huvud</p>	<p>⑦</p>	 <p>x 16 M8*80 Expansionskruv</p>	<p>⑬</p>	 <p>x 12 4,2*16 skruv med platt huvud</p>
<p>②</p>	 <p>x 4 Basplattans lock</p>	<p>⑧</p>	 <p>x 4 Stolphörna Förlängningsstycke</p>	<p>⑭</p>	 <p>x 8 4,2*19 Borrskruv</p>
<p>③</p>	 <p>x 4 Basplatta</p>	<p>⑨</p>	 <p>x 56 Skaft hållarlock</p>	<p>⑮</p>	 <p>x 1 Mottagare &Takfjärrkontroll</p>
<p>④</p>	 <p>x 16 M8*12 sexkantsskruvar (Med bricka)</p>	<p>⑩</p>	 <p>x 112 M5*16 Försänkt skruv</p>	<p>⑯</p>	 <p>x 1 Reservdelar</p>
<p>⑤</p>	 <p>x 16 M8*25 sexkantsskruvar (Med bricka)</p>	<p>⑪</p>	 <p>x 28 M6*5 sexkantsskruv</p>	<p>⑰</p>	
<p>⑥</p>	 <p>x 16 M8*35 sexkantsskruvar (Med bricka)</p>	<p>⑫</p>	 <p>x 4 L Stolpe Top Cover</p>	<p>⑱</p>	

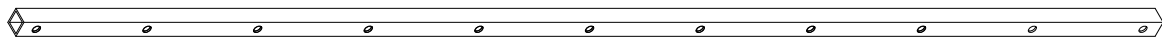
Profillista

<p>A-1 ~ A-4</p>			<p>x 4 Posta</p>
<p>B-2 B-4</p>			<p>x 2 Balk & ränna</p>
<p>B-1</p>			<p>x 1 Balk och ränna (med skafthållare)</p>
<p>B-3</p>			<p>x 1 Balk & ränna (med axelhållare) + Motor</p>
<p>C-1</p>			<p>x 1 Motoranslutningsbländskydd</p>
<p>C-2</p>			<p>x 27 Louvren</p>
<p>D</p>			<p>x 1 Styrstav</p>
<p>E</p>			<p>x 4 T-spårskydd</p>

Aluminiumprofiler Lay Out Ritning

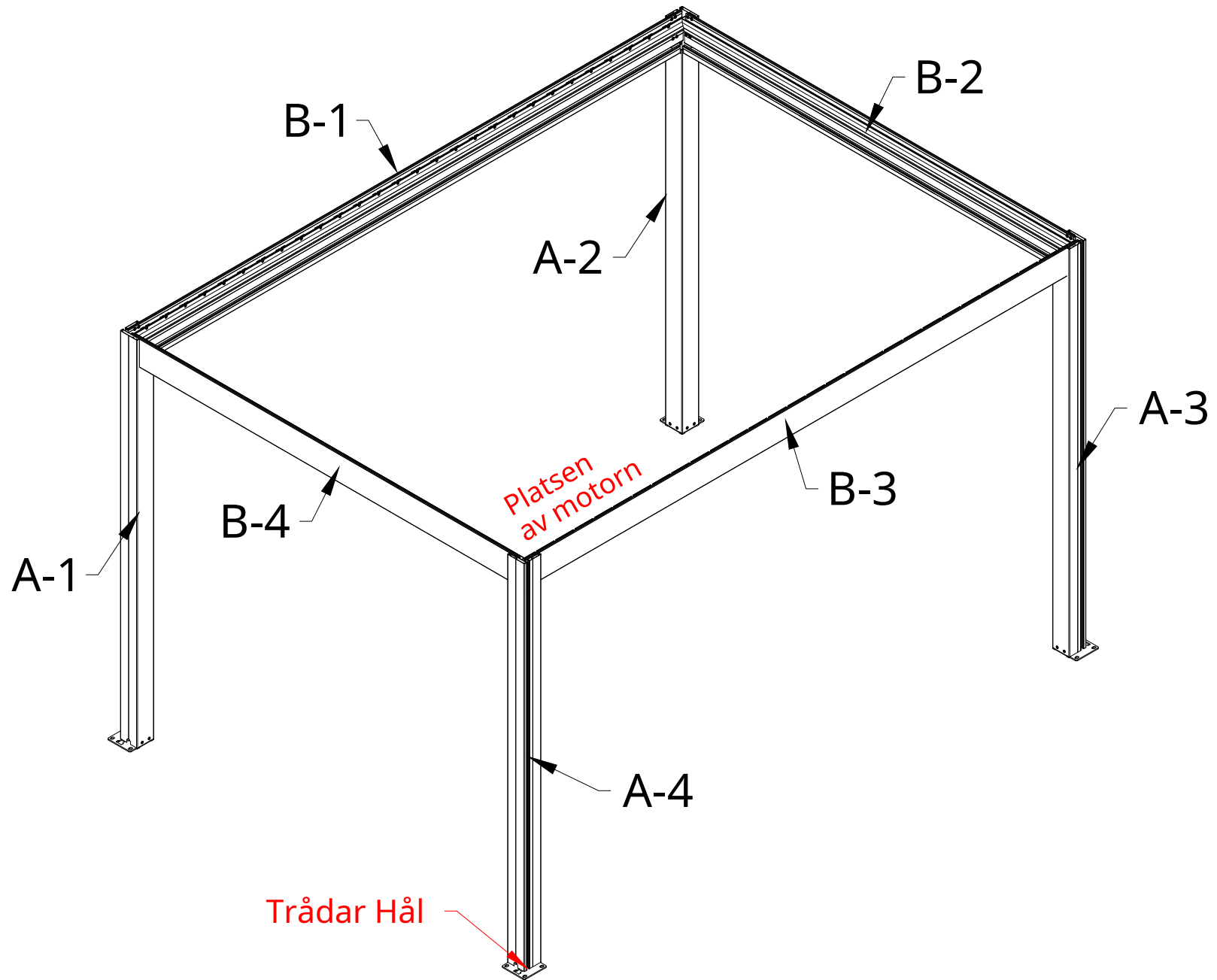

1

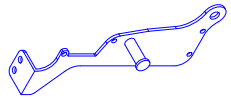

x 1



x 4

Installation av motoranslutningsbländskydd

1) Fixerade knivskyddet på motoranslutningsbländskyddet C-1 med 4*20 plattsruvar.

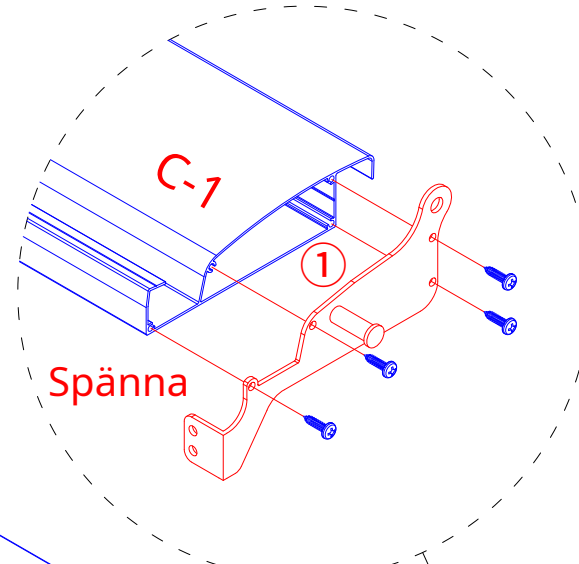

Steg 1

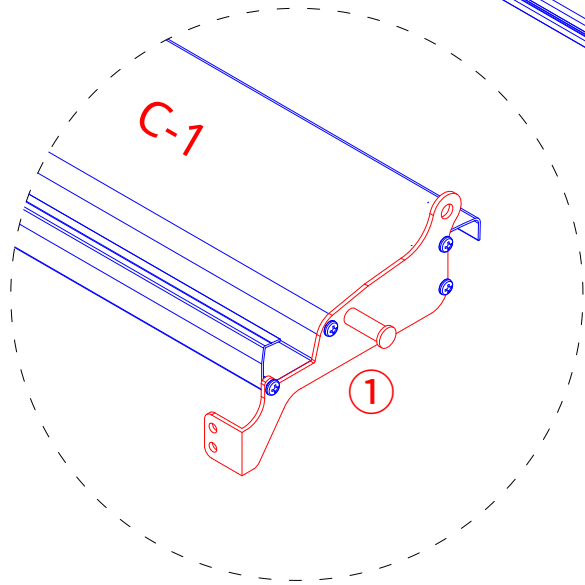

Steg 2

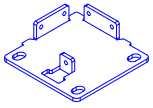
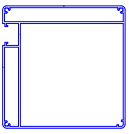
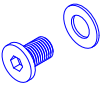

Om installationsplatsen är trång kan klingskydden installeras efter att ramverket har installerats.

③		x 4	A-1 ~ A-4		x 4
④		x 16			

Sätt ihop ramverket

1) Sätt i bottenplattans lock som visas ② in i inläggen, rikta sedan in hålen i bottenplattan ③ med hålen i stolparna och lås bottenplattan ③ till stolparna med M8*12 sexkantsskruvar (med bricka) ④.

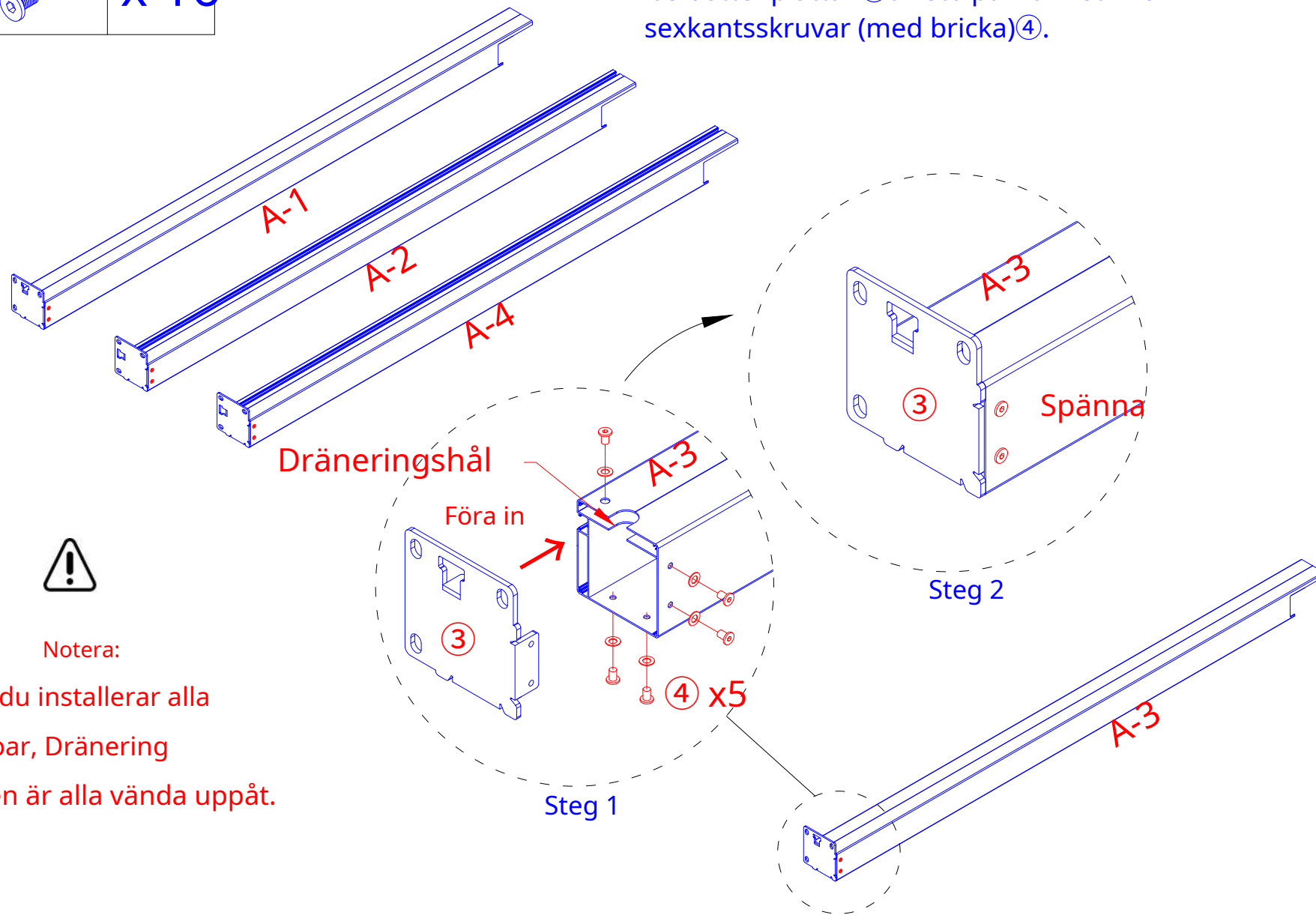

Notera:

När du installerar alla stolpar, Dränering
Hålen är alla vända uppåt.

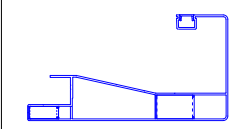
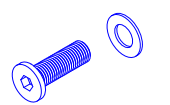
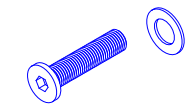
B-1 B-3		x 2
⑤		x 8
⑥		x 8

Sätt ihop ramverket

2) Som visas, sätt in balken och rännan (B-1, B-3) in i inläggen, fixade sedan balken och rännan (B-1, B-3) på stolparna med M8*25 sexkantsskruvar⑤ och M8*35 sexkantsskruvar⑥ .

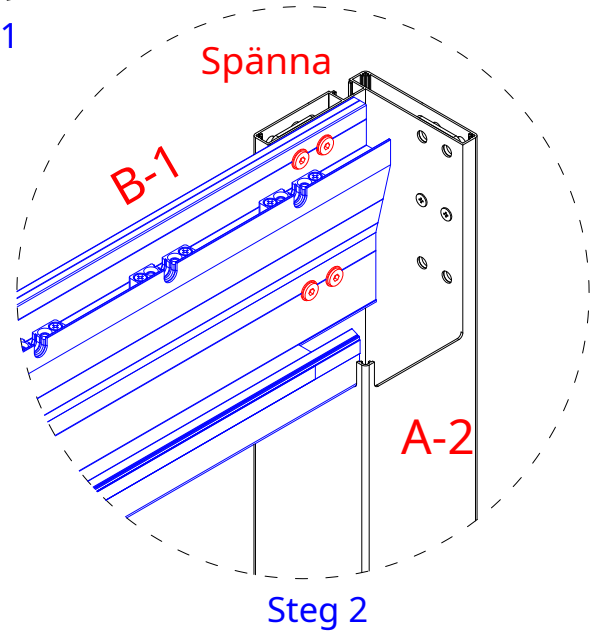
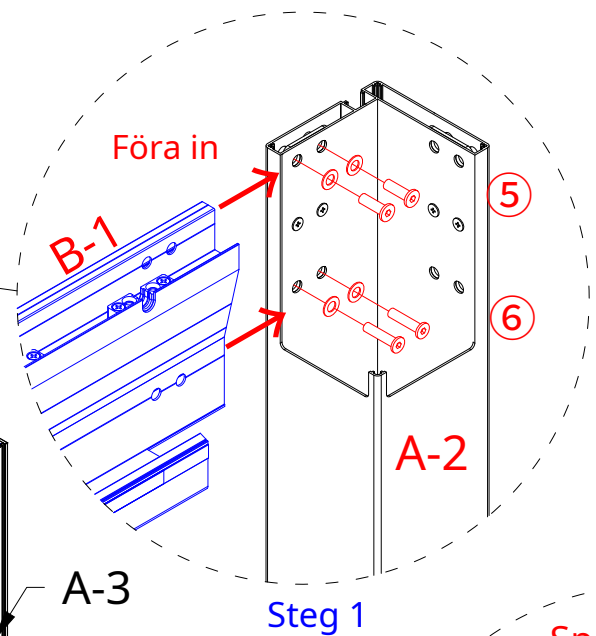
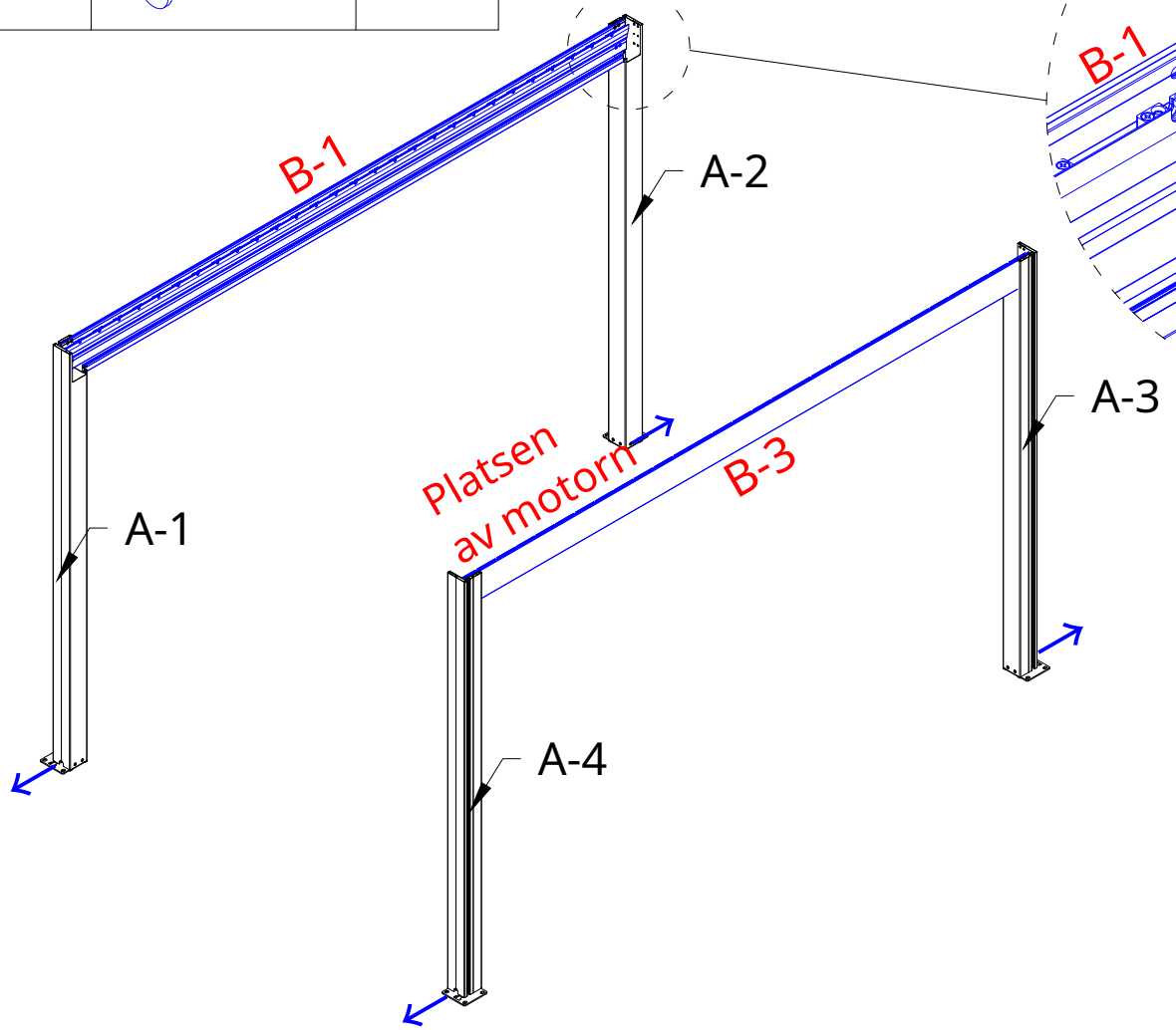

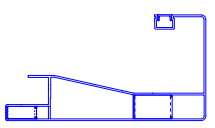
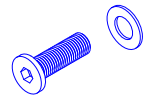
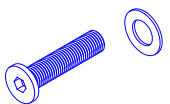
B-2 B-4		x 2
⑤		x 8
⑥		x 8

Sätt ihop ramverket

3) Sätt in balken och rännan enligt bilden B-2, B-4 in i inläggen, fixade sedan balk & ränna B-2, B-4 på stolparna med M8*25 sexkantsskruvar ⑤ och M8*35 sexkantsskruvar ⑥.

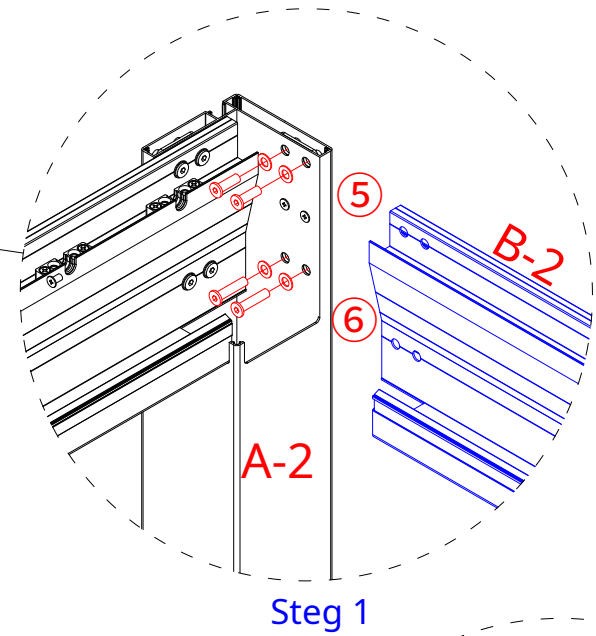
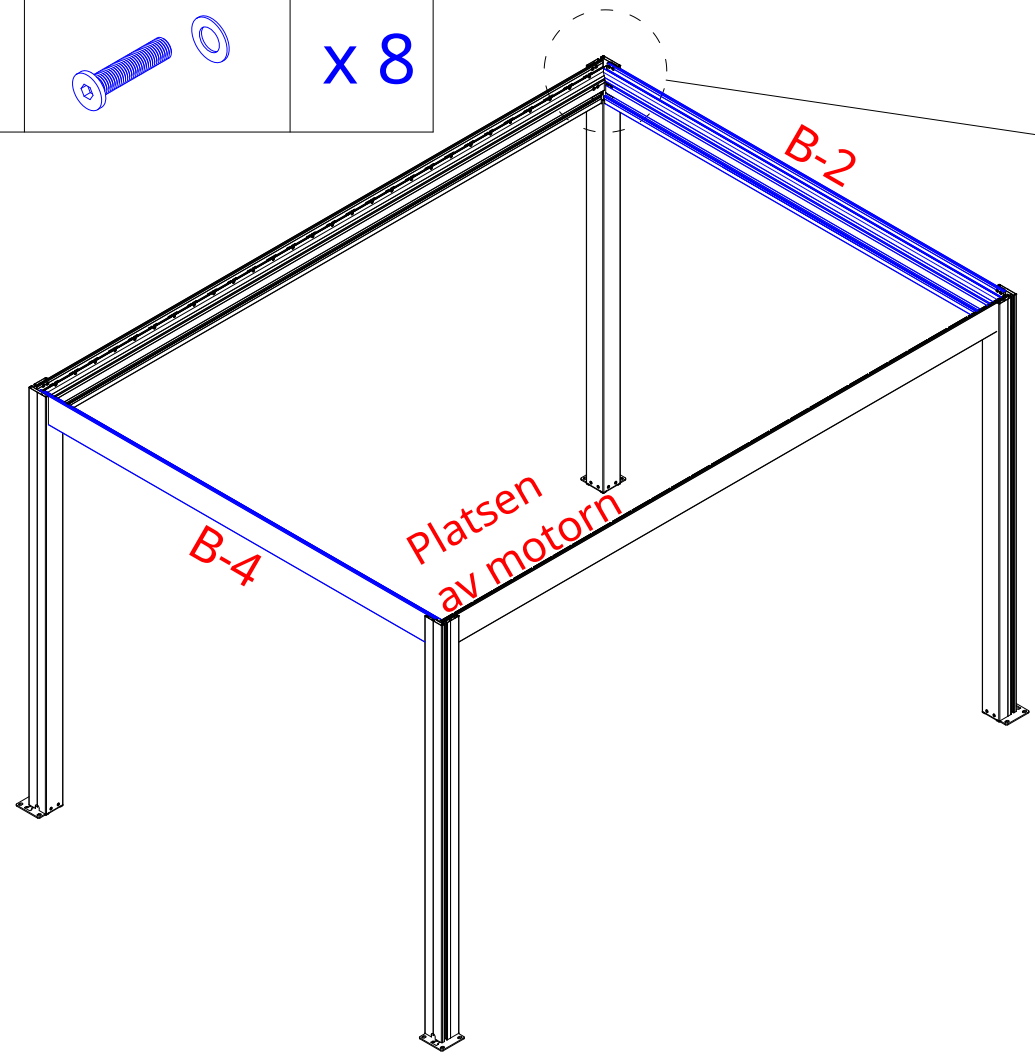

Steg 1

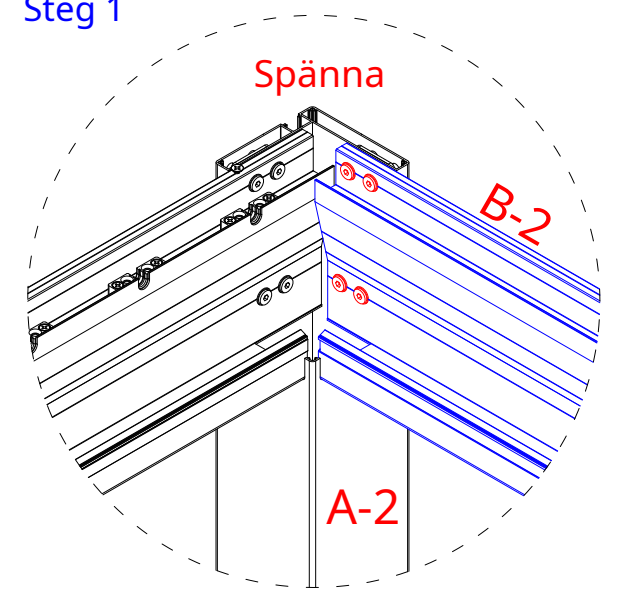

Steg 2

7

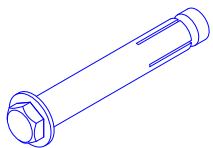

x 12

Notera:



Innan du fäster basplattan är det nödvändigt att se till att diagonalerna på de 4 stolparna är lika långa. Se till att storleken $W1=W2, W3=W4$.

Fixa Pergola till marken

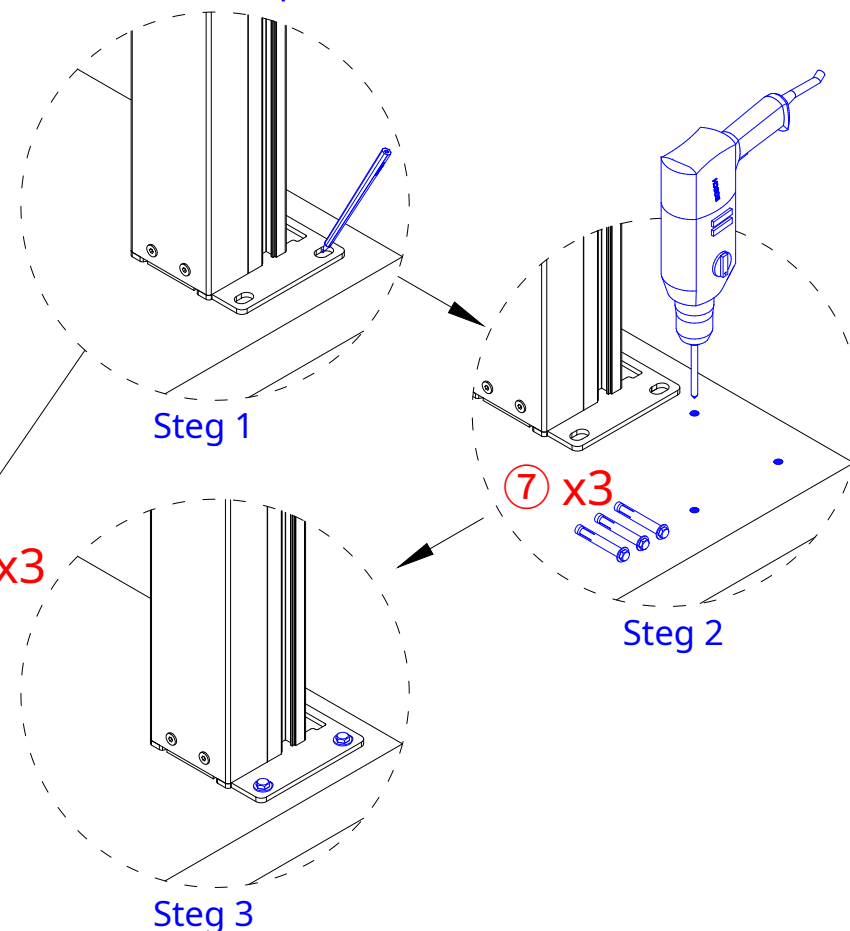
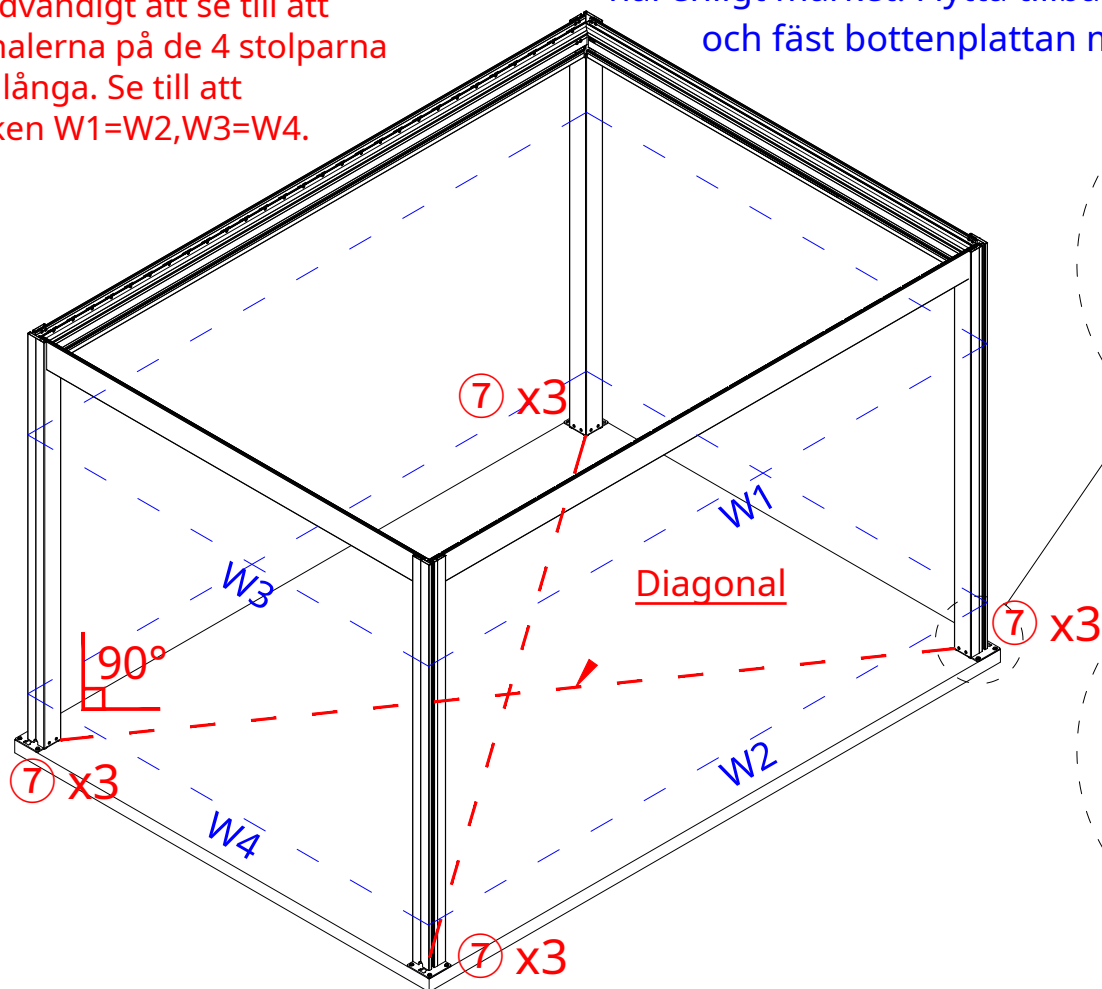
- 1) Använd 12 M8*80 expansionsskruv ⑦ tillhandahålls, om marken är betonggolv. Om inte måste du hitta en annan lösning för att skruva fast din pergola på önskad yta.
- 2) Flytta pergolan till lämplig installationsposition, markera sedan positionen för de fyra stolparna med pennan, ta bort pergolan och använd den elektriska borren för att göra 12 hål enligt märket. Flytta tillbaka pergolan till positionen och fäst bottenplattan med M8*80 expansionsskruv ⑦.



Det är användarens ansvar att se till att pergolan är fixerad. Tillverkaren ansvarar inte för skador orsakade av naturkatastrofer eller speciella händelser på pergolan (eller dess tillbehör). Varje pergola som inte är fixerad kan sprängas och orsaka skada, och detta ansvar kommer inte att tillskrivas tillverkaren. Kontrollera pergolan regelbundet för att säkerställa att den förblir stabil och stadigt fäst vid marken. En pergola som lossnar från sin position och ådrar sig eller orsakar skada täcks inte av garantin.

 LED-tråd
 Strömkabel

Kör ledningarna

När du lägger ut ledningarna, skjut in dem i stolpen från skåran i den övre änden av stolpen, dra sedan ledningarna till utloppshålet, dra sedan ut ledningarna från utloppet och ta slutligen ut från hålet i botten av posten.

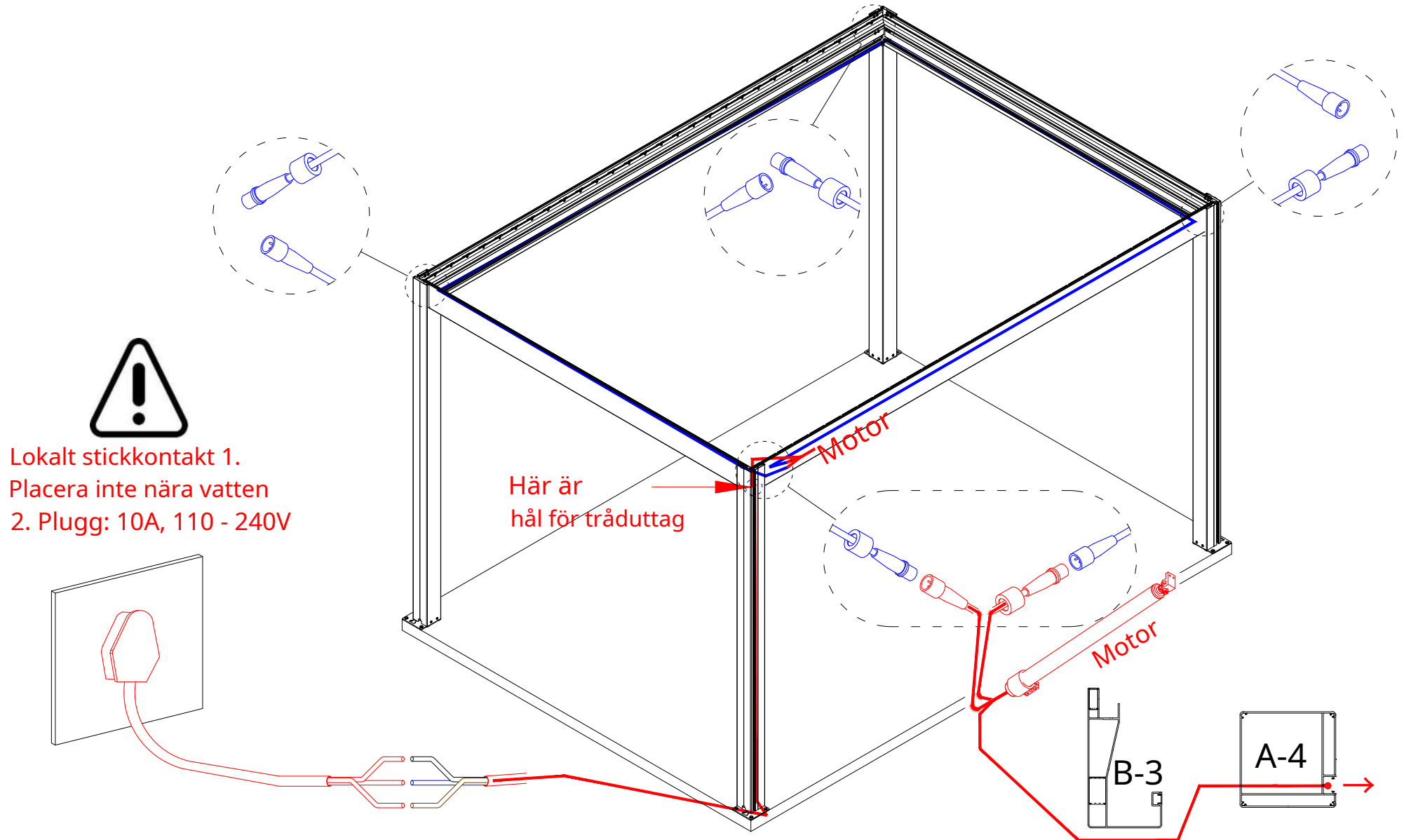



Obs: Följ stegen för att ansluta kabeln korrekt, annars kommer motorn att vara felaktig.



Kontakten medföljer inte

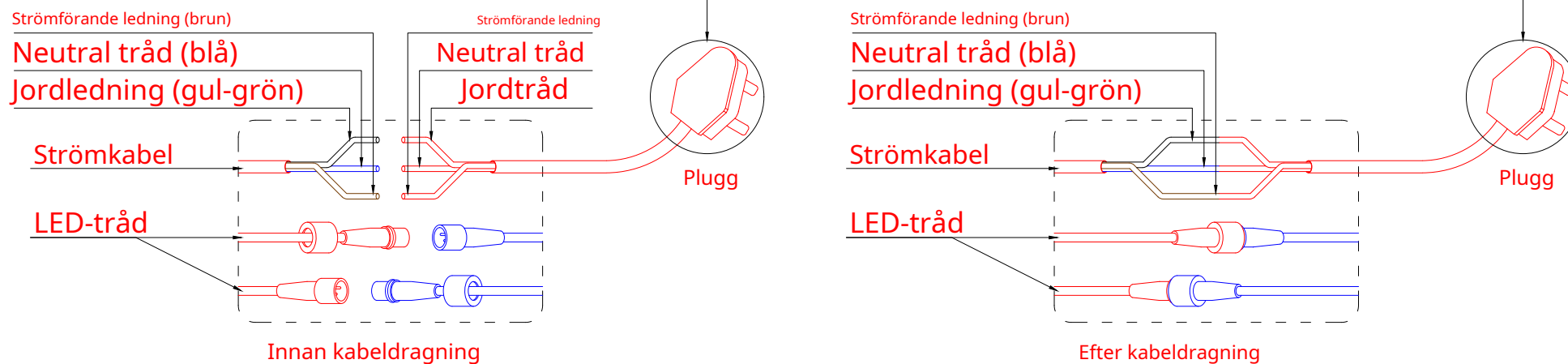

8

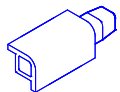

x 4

Fixa stolphörnets förlängningsstycke

1) Som visas, skjut gärna in stolphörnets förlängningsstycke i den övre delen av stolphörnet.

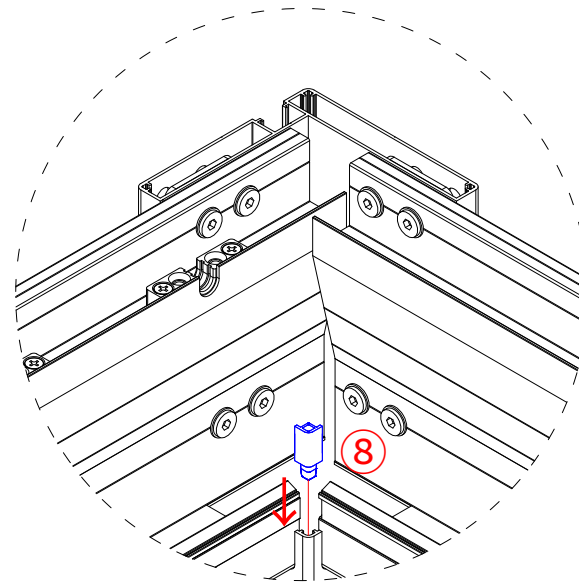
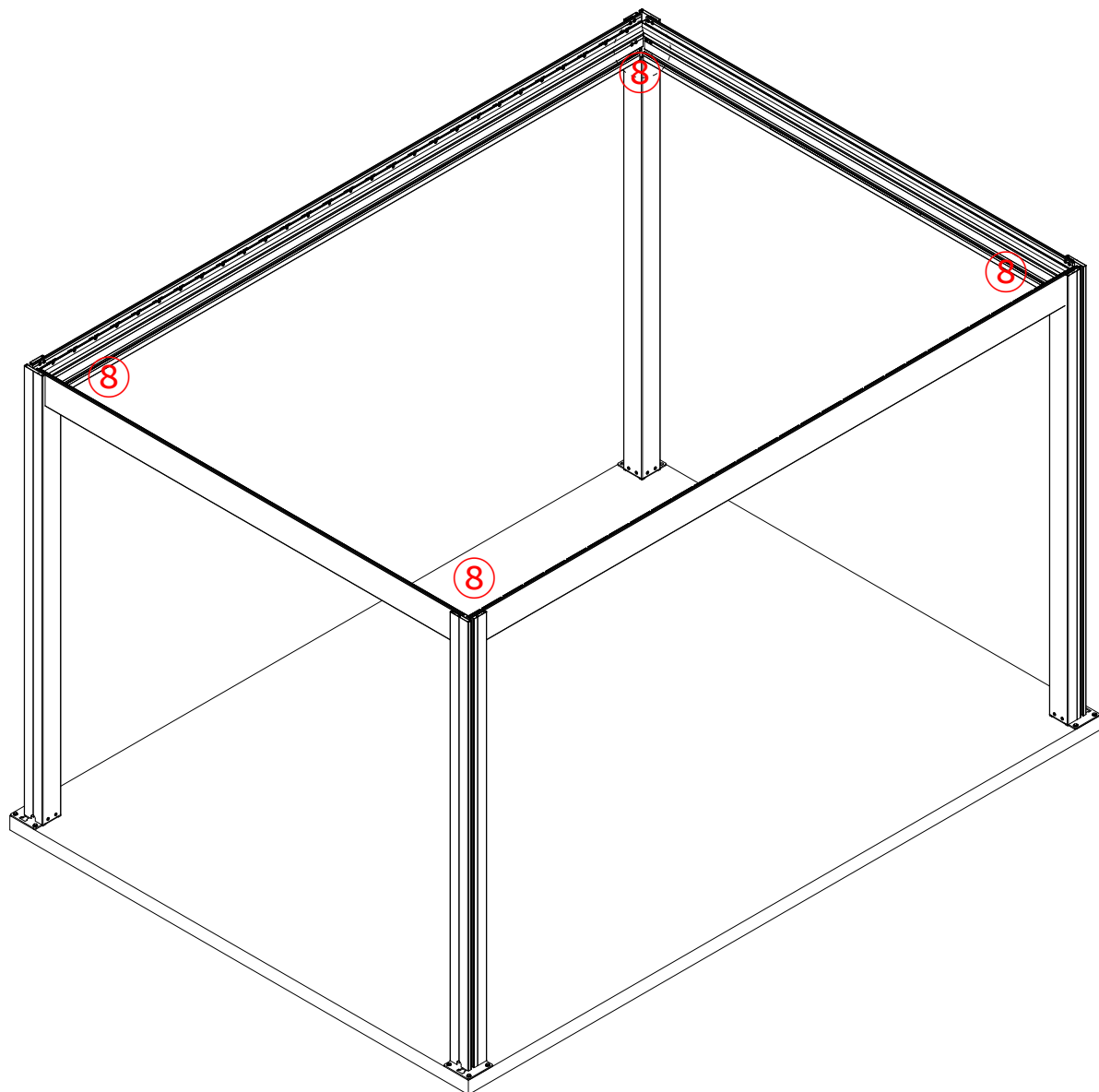

Steg 1

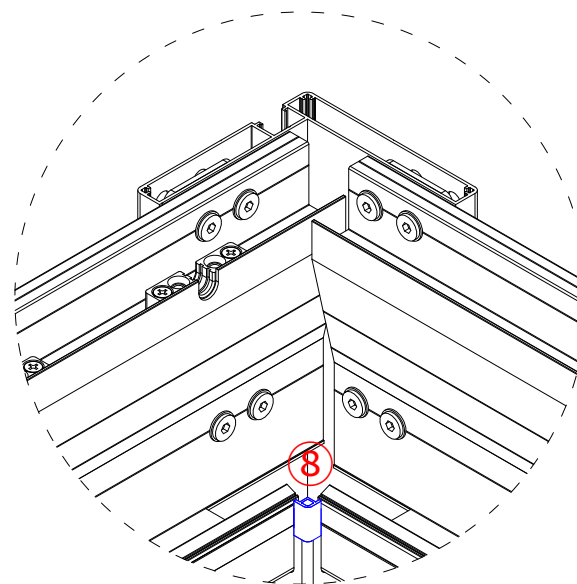

Steg 2

C-1

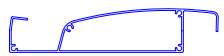

x 1

Installation av bländskydd

- 1) Som visas klickar motoranslutningsbländskyddet C-1 direkt in i spåret.
- 2) Anslut motorarmsfästet till ändlocket på Motor Connecting Louvre C-1.

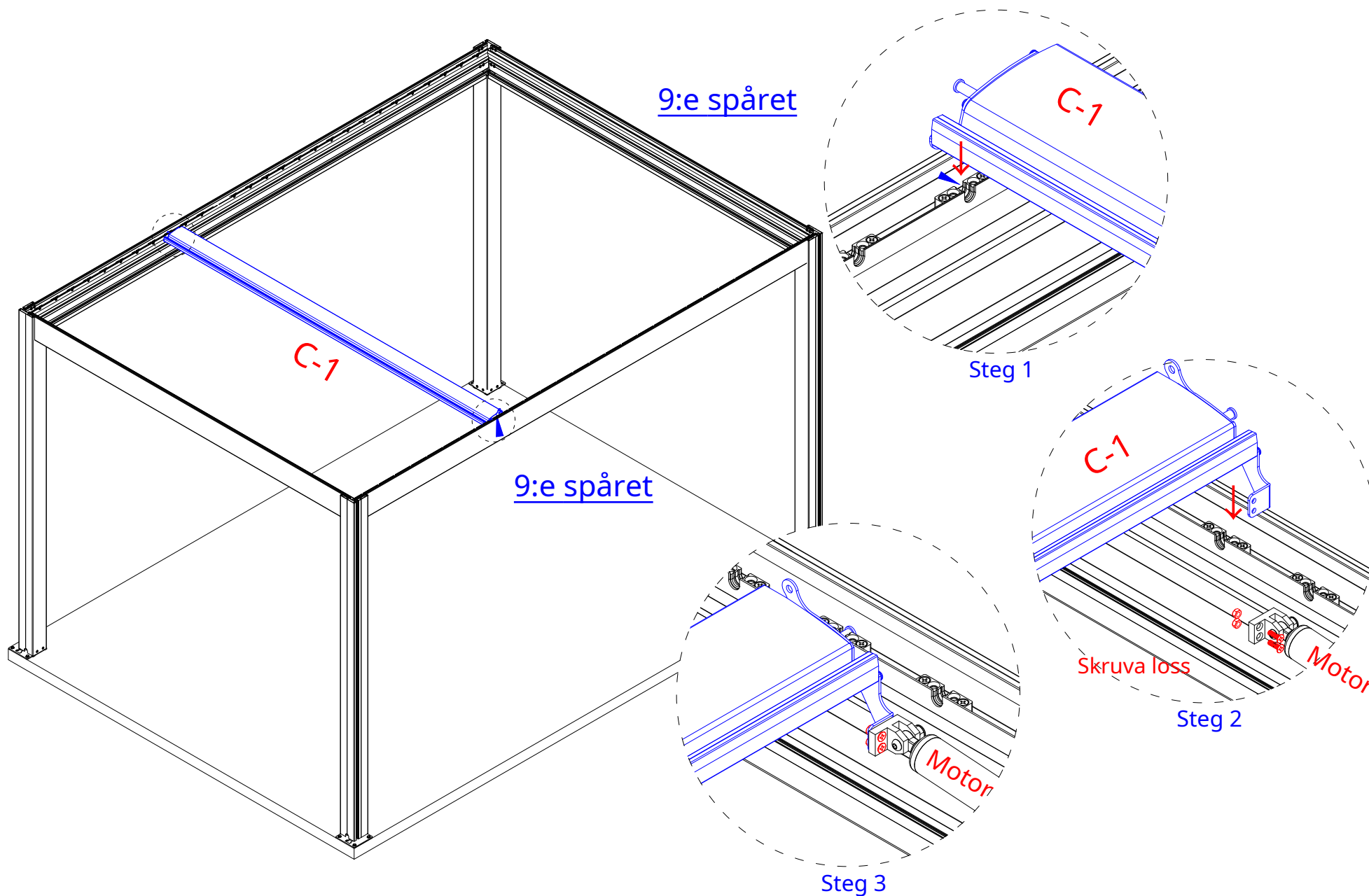

C-2 x 27



Installation av bländskydd

3) Som visas klickar bländskyddet C-2 direkt in i spåret.

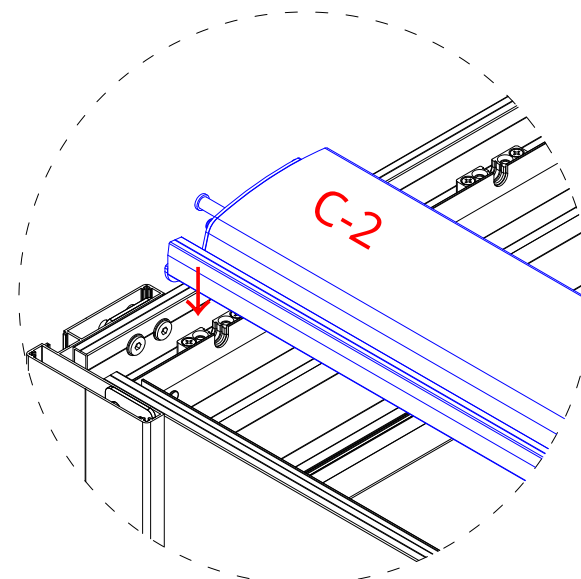
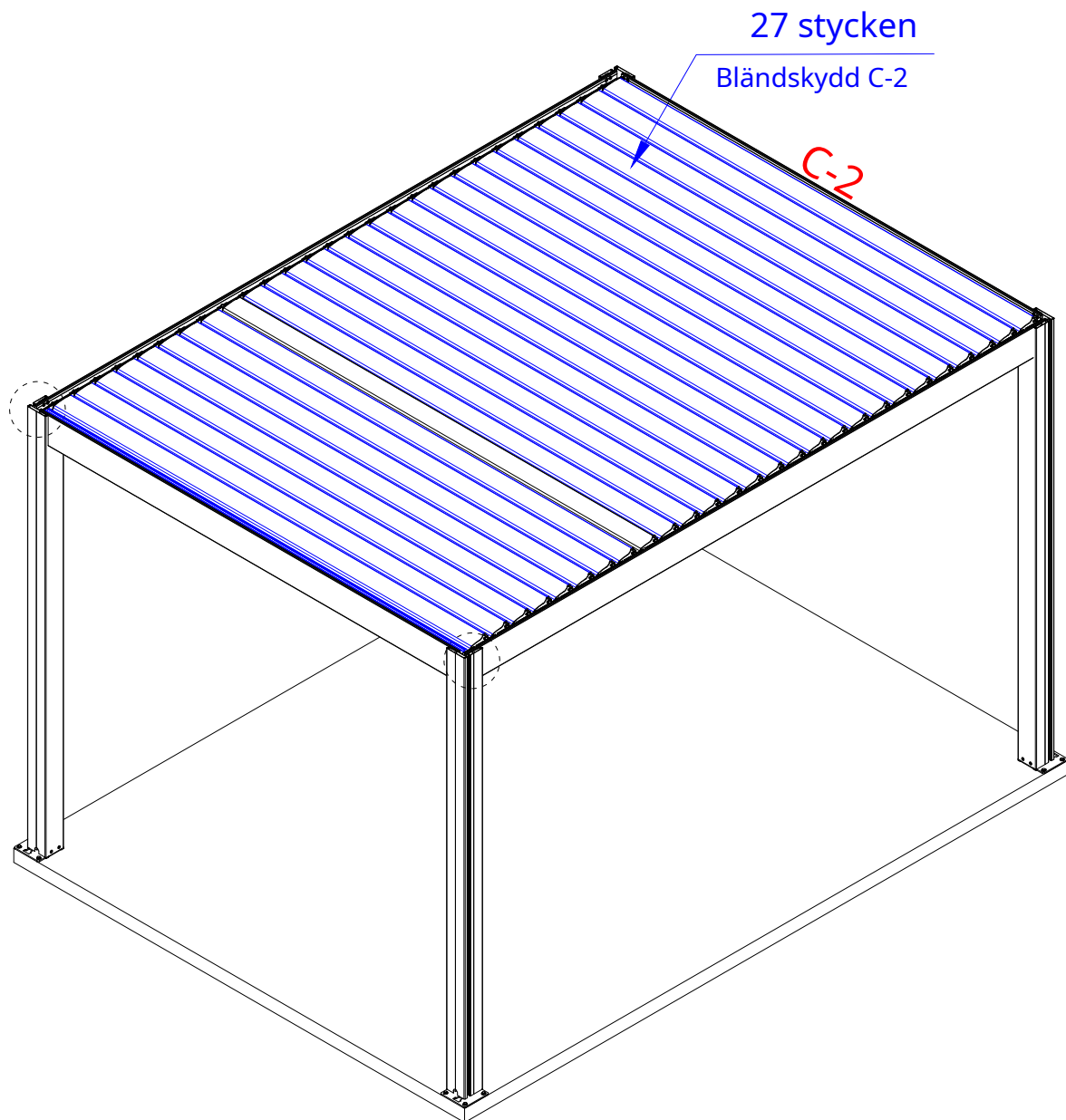

Steg 1

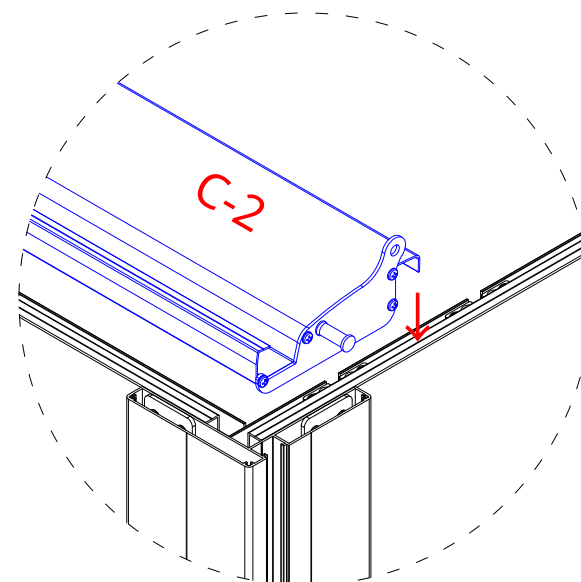

Steg 2

9

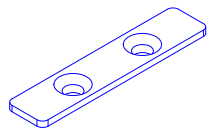

x 56

10



x 112

Installation av bländskydd

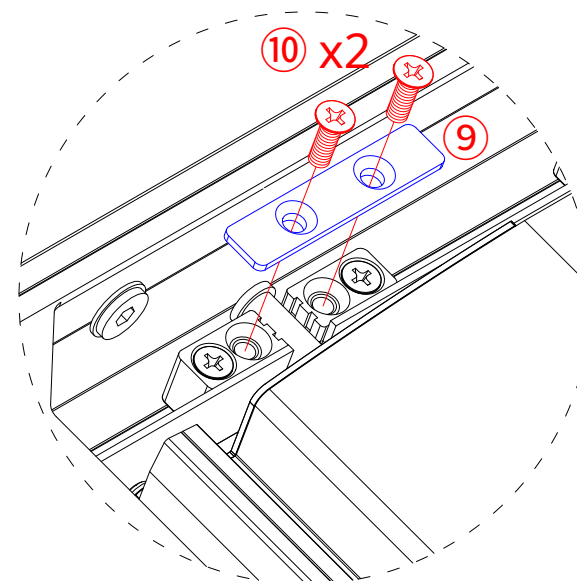
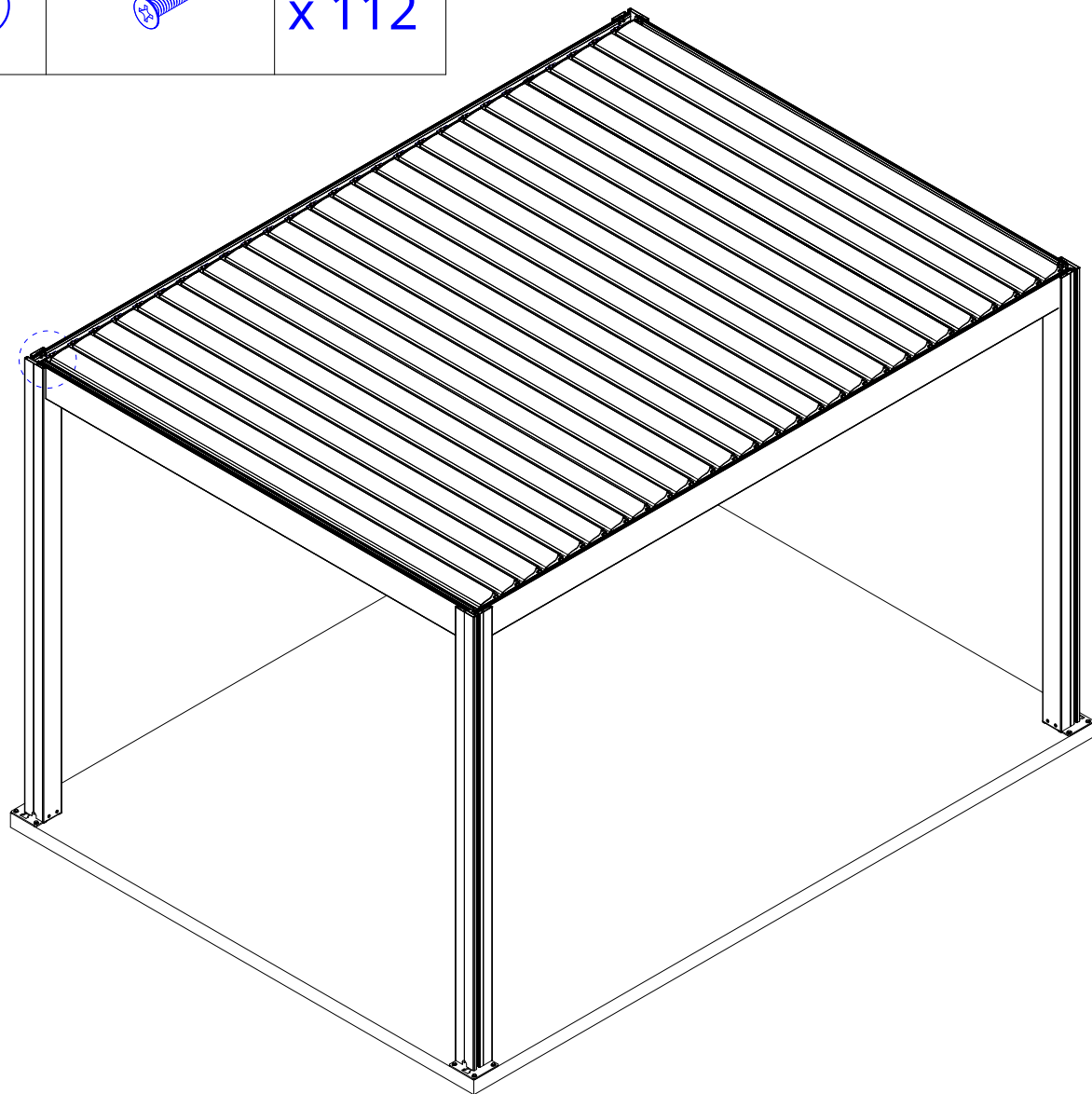

4) Fixera skafthållarlocket enligt bilden 9 på axelhållare med
M5*16 Försänkt skruv 10.

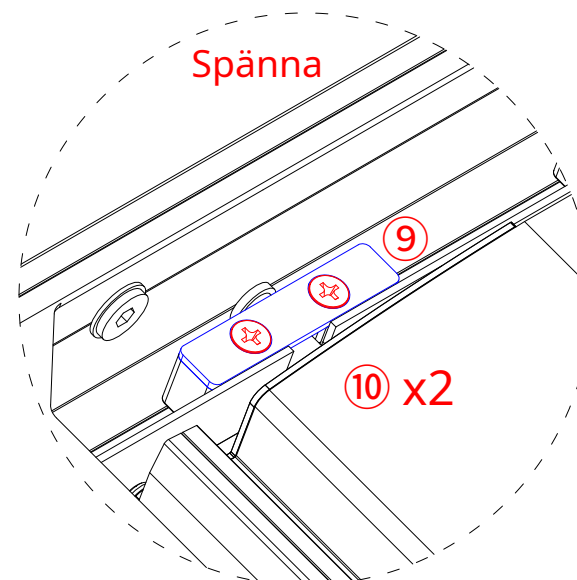

Steg 1



Steg 2

D		X 1
11		X 28

Installation av bländskydd

5) Som visas, använd M6*5 sexkantskruv 11 genom hålet (på styrstången D), fixeras sedan på gallret.

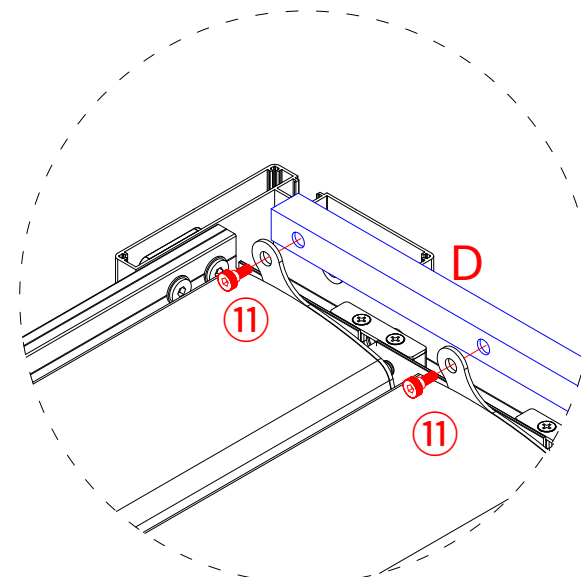
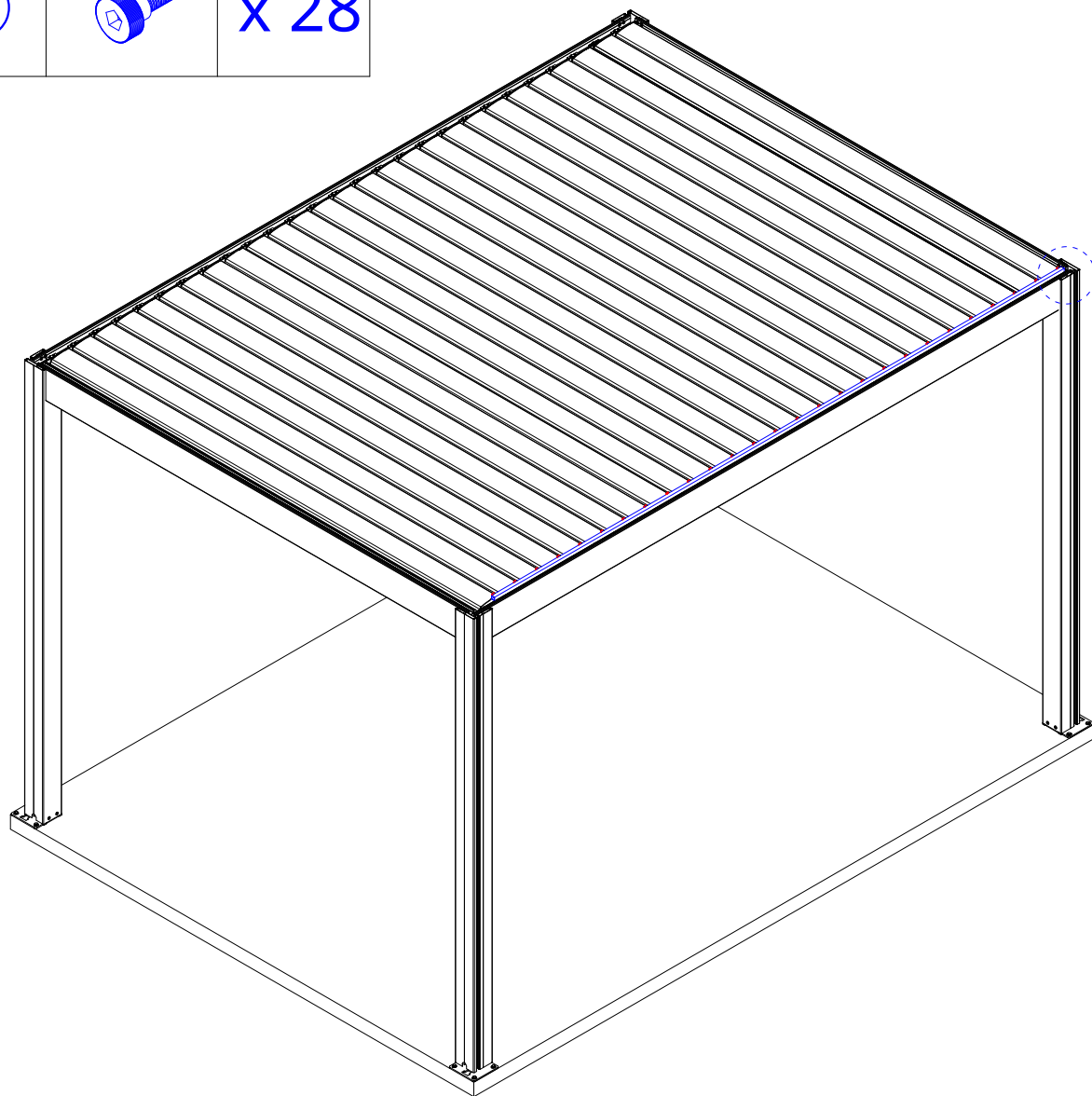

Steg 1

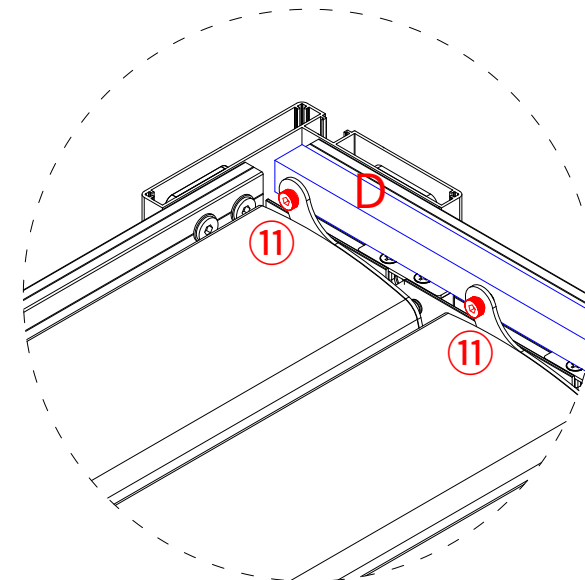



Steg 2

E**x 4****Fixa T-Slot Cover**

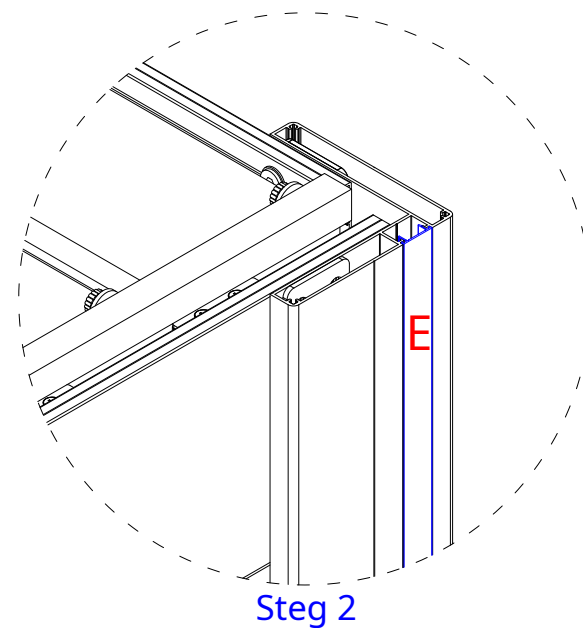
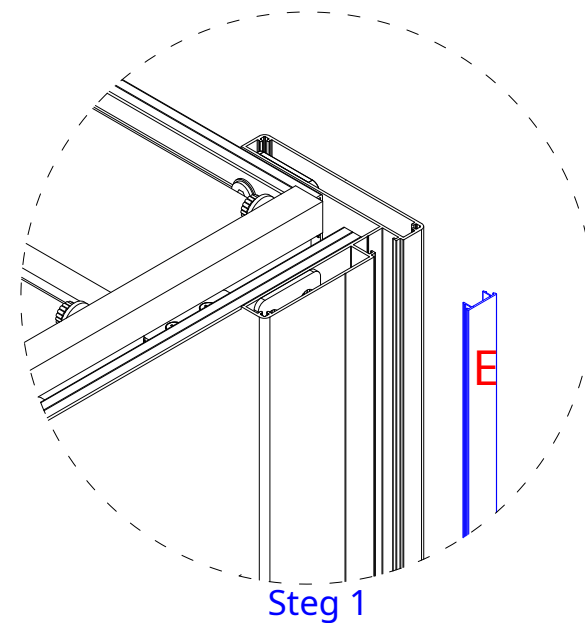
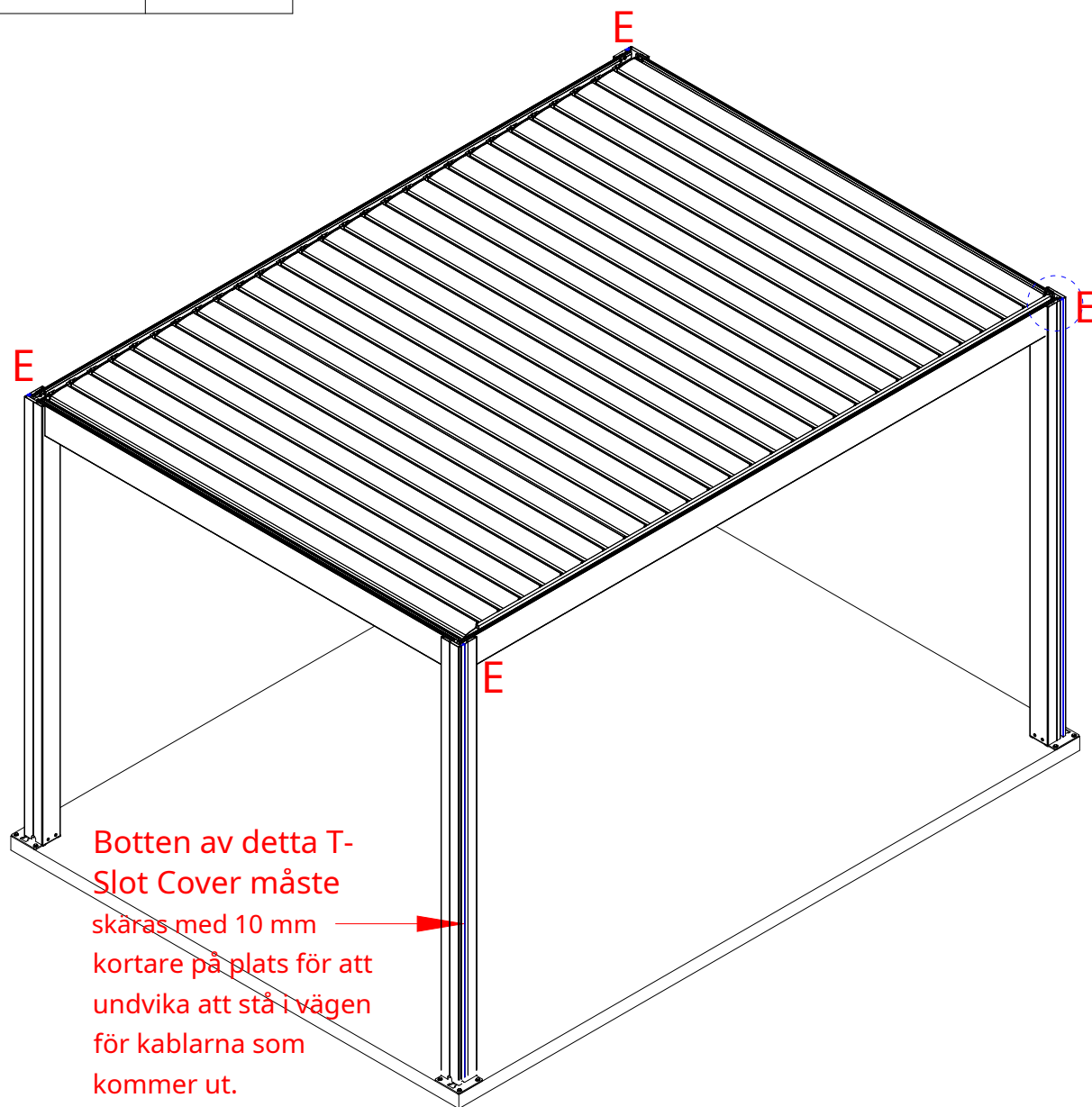
1) Som bilden visar, sätt in T-spårkåpan E i stolpens spår.

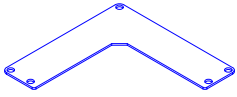

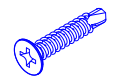
12		x 4
13		x 12
15		x 8

Fixera stolpens övre kåpa

2) Sätt på den L-formade gavelplattan enligt bilden 12 på toppen av stolpen och fixera den sedan med 3 av 4,2*16 självgående skruvar 13 och 2 av 4,2*19 borskruvar 15.

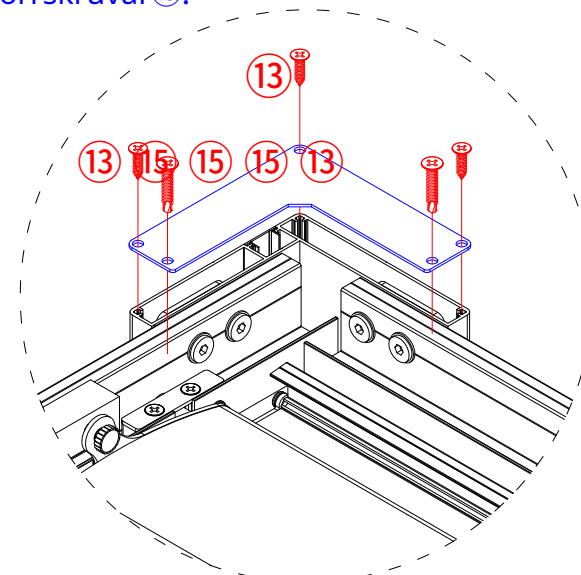
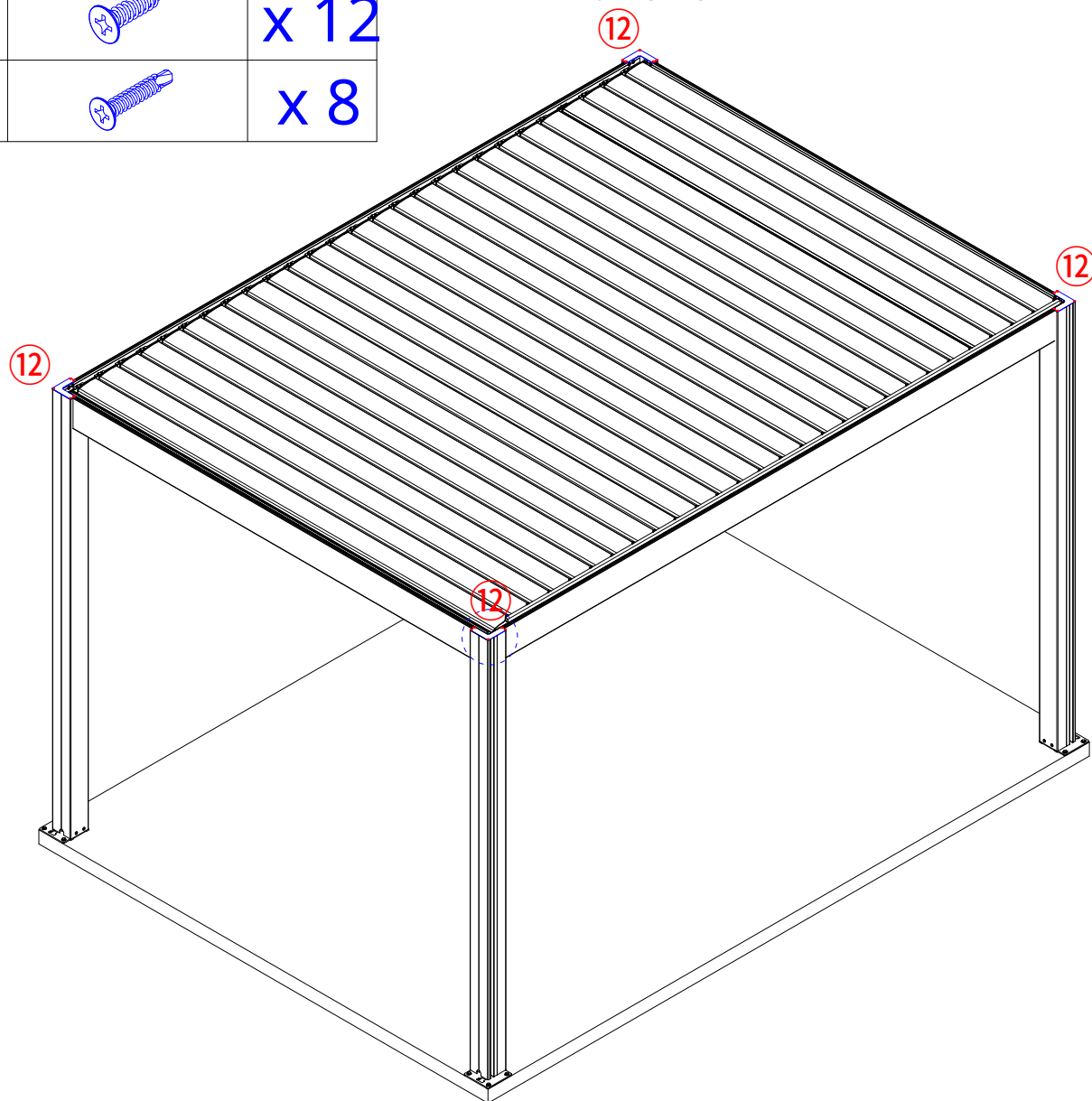

Steg 1

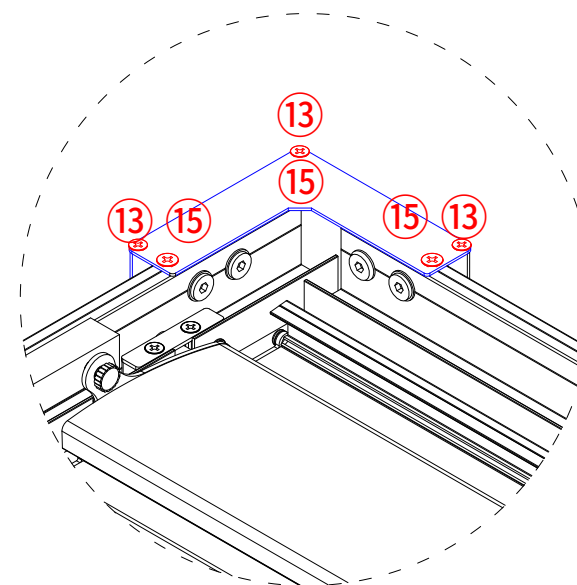

Steg 2

2

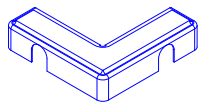

x 4

Installation av basplattans lock

1) Som visas ska den U-formade skåran på bottenplattans lock vara orienterad i samma riktning som avloppsöppningen. Basplattans lock på stolpen med extra utloppsskåra.

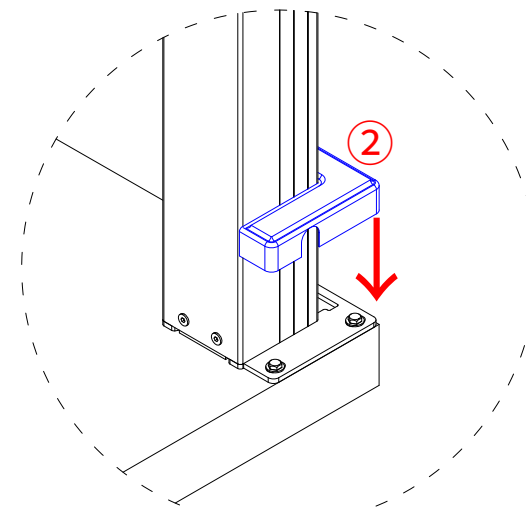
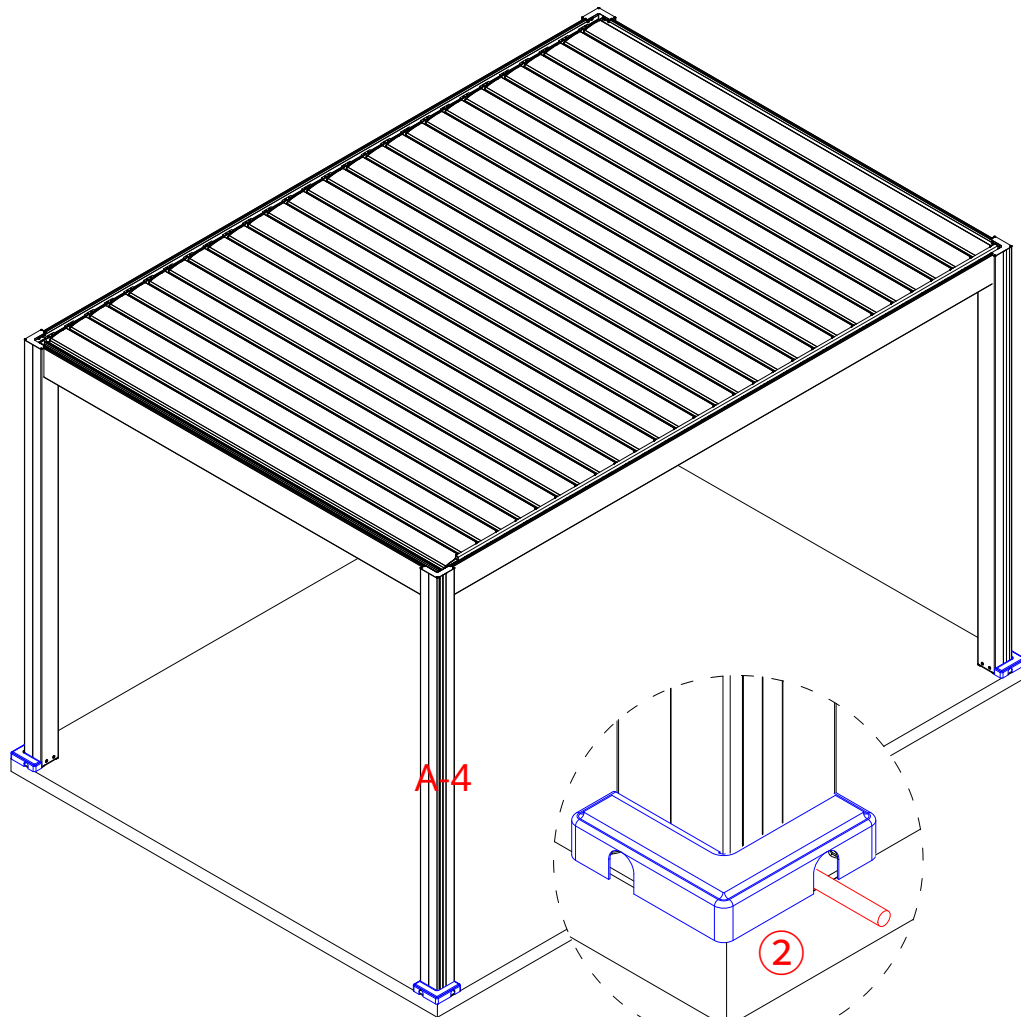

Steg 1

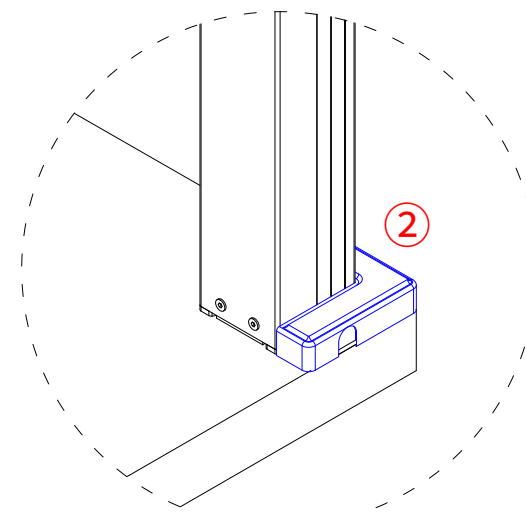

Steg 2

När fjärrkontrollen och mottagaren inte kan styra motorn,
följ stegen nedan för att programmera om.

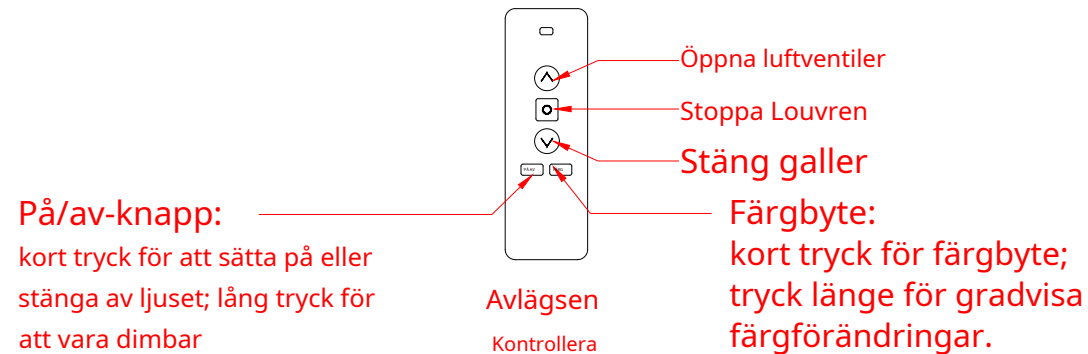

Steg för ihopparning:

①

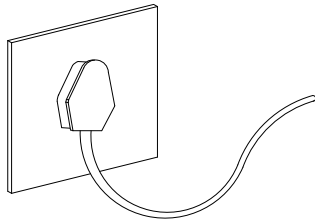

Stäng av strömmen i 15 sekunder och anslut sedan strömmen igen starta följande steg inom 30 sekunder.

②



Öppna bakstycket på fjärrkontrollen/mottagaren, tryck och håll ned **U2-knappi** mer än 7 sekunder.

③

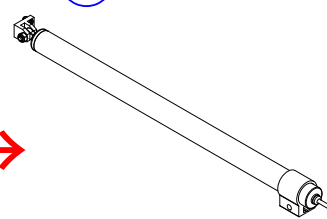

När motorn fortsätter att göra en "**pip pip pip**" ljud.

④

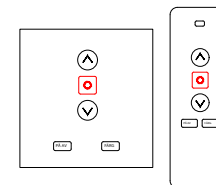

Tryck och håll ned **stoppknapp** på fjärrkontrollen/mottagaren i mer än 2 sekunder igen. När "**pip pip pip**" ljudet från motorn försvinner betyder det att fjärrkontrollen/mottagaren har parats ihop.

Steg som ändrar riktning:

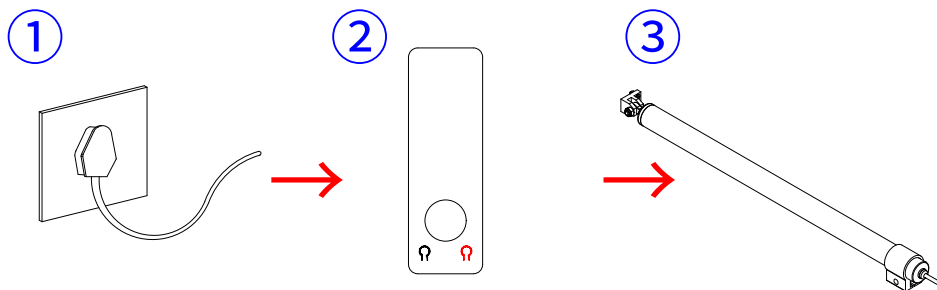

Stäng av strömmen i 15 sekunder och anslut sedan igen kraften alltså snälla starta följande steg inom 30 sekunder.

Öppna bakstycket på fjärrkontrollen/mottagaren, tryck och håll ned **U2-knappi** mer än 7 sekunder.

När motorn fortsätter att göra en "**pip pip pip**" ljud.

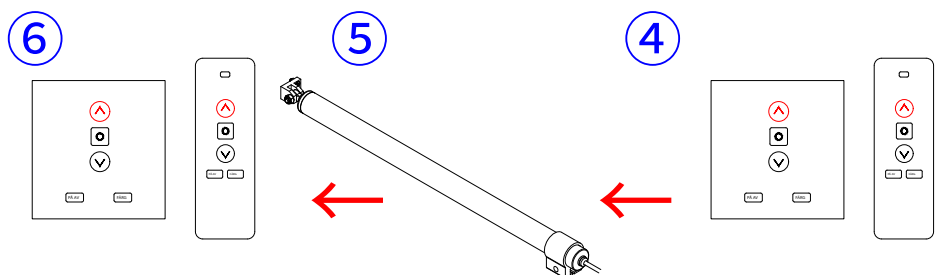

Tryck och håll ned **upp-knappen** på fjärrkontrollen i mer än 2 sekunder.

Motorn gör en "**pip pip pip**" ljud igen

Tryck och håll ned **upp-knappen** av fjärr/mottagare för mer än 2 sekunder.

Parning Raderingssteg:

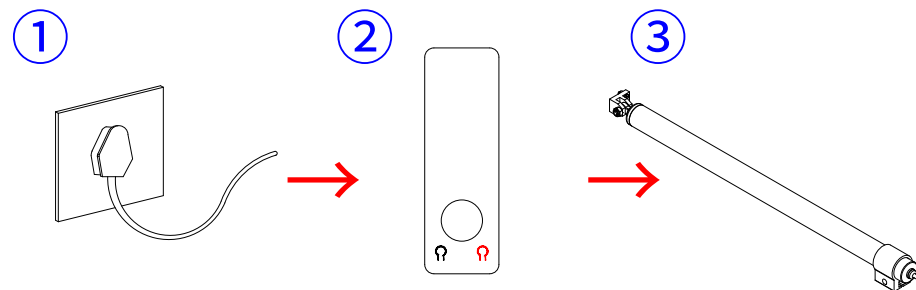

Stäng av strömmen i 15 sekunder och anslut sedan igen kraften alltså snälla starta följande steg inom 30 sekunder.

Öppna bakstycket på fjärrkontrollen/mottagaren, tryck och håll ned **U2-knappi** mer än 7 sekunder.

När motorn fortsätter att göra en "**pip pip pip**" ljud.

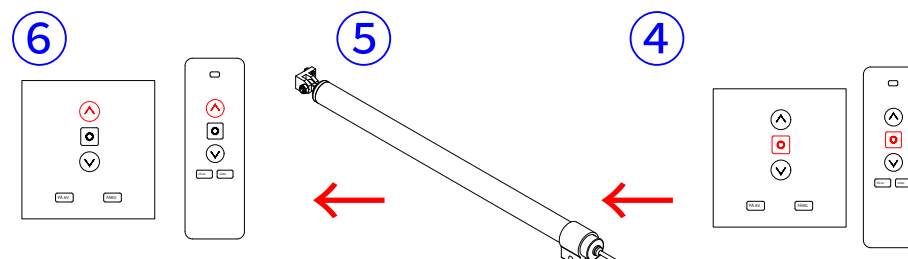

Tryck och håll ned **upp-knappen** av fjärrkontrollen/mottagaren för mer än 2 sekunder. Ta bort parningen framgångsrikt.

Motorn gör en "**pip pip pip**" ljud igen

Tryck och håll ned **stoppknapp** av fjärrkontrollen/mottagaren för mer än 2 sekunder.

Ta hand om din pergola

Strukturytor belagda med värmehärdande pulverlacker måste rengöras en gång per år för att behålla sitt ursprungliga estetiska utseende.

Termohärdande pulver är känsliga för:

- Fysisk friktion, hård stöt, extrudering, kemikalier inklusive alkaliska lösningsmedel och sura lösningsmedel.
- Naturliga element som vind, regn, snö och långvarigt solljus. Pergolans utsida kan försämrans med tiden och detta täcks inte av garantin.

Rengöring av din pergola

- Använd inte skursvamp, krämrengöringsmedel, slipsvamp, järntrådkula eller färgade trasor.
- Rekommenderas: Mjuk svamp, mjuk sandfri trasa, bomullsull, bomull eller non-woven papper (endast vitt).
- Använd inte frätande produkter som sura eller alkaliska rengöringsmedel. Det rekommenderas att tvätta med neutralt pH-vatten och sedan torka av det med en trasa för att hålla det torrt.
- Vid rengöring med högtrycksutrustning måste samma försiktighetsåtgärder vidtas som vid rengöring av karossen: avstånd, munstyckstyp, vattentemperatur och tryck bör alla beaktas.

Använd påminnelse

- När installationen är klar, kontrollera att skruvarna är åtdragna. Kom ihåg att kontrollera skruvarna minst en gång per år.
- **I de fall där snöfall, hagel eller starka vindar över 80 km/h förutspås, rekommenderas att öppna bländskyddet. Använd inte knivarna vid frost eller snö. Ta bort bladen från pergolan när det är mycket snö.**
- Kontrollera regelbundet tätningsförhållandena för att säkerställa att tätningarna eller andra komponenter inte läcker.
- Rensa regelbundet upp skräp som fallna löv på pergola för att förhindra att avloppet täpps igen.
- Användningsbegränsningar: Vattentäta system är, även om de är effektiva, inte utformade för att säkerställa fullständig vattentätning. Kraftigt regn och hård vind kan skada pergolan. Eventuella skador täcks inte av garantin.